

User Manual ABO620

V1.02

Preface

Thank you for choosing Oxin Drive **ABO620 Series General Purpose AC Motor Drives**. This user manual presents a detailed description of ABO620 series with respect to product features, structural characteristics, functions, installation, parameter setting, troubleshooting, commissioning and daily maintenance, etc. Be sure to carefully read through the safety precautions before use, and use this product on the premise that personnel and equipment safety is ensured.

IMPORTANT NOTES

- Please assure the intactness of product enclosure and all safety covers before installation .Operation must conform to the requirements of this manual and local industrial safety regulations and/or electrical codes.
- Contents of this manual may be subject to appropriate modification as a result of product upgrade, specification change and update of the manual.
- In the event of damage or loss of user manual, users may ask local distributors, offices or our Technical Service Department for a new one.
- If any item as stated in this manual is not clear, please contact our Technical Service Department.
- If any anomaly occurs after power up or during the operation, it is essential to stop the machine and identify the fault or seek technical services as soon as possible.
- Telephone number of our Technical Service Department: (+98) 2146803105.

Table of Contents

Preface	- 1 -
Chapter 1 Safety Precautions	- 1 -
1.1 Safety Considerations	- 1 -
1.2 Other Considerations	- 5 -
Chapter 2 Product Information	- 7 -
2.1 Model Explanation.....	- 7 -
2.2 Nameplate Information.....	- 7 -
2.3 Information of Product Model	- 8 -
2.4 Technical Features of ~ABO620	- 11 -
2.5 Parts Drawing	- 15 -
2.6 Appearance, Mounting Dimensions and Weight	- 17 -
2.7 External Dimensions of Control Panel	- 23 -
2.8 External Dimensions of Control Panel Bracket	- 23 -
Chapter 3 Installation and Wiring	- 24 -
3.1 Installation Environment.....	- 24 -
3.2 Minimum Mounting Clearances	- 24 -
3.3 Remove & Mount Control Panel and Cover	- 26 -
3.4 Configuration of Peripheral Devices	- 31 -
3.5 Terminal Configuration	- 35 -
3.6 Main Circuit Terminals and Wiring	- 35 -

3.7	Control Terminal Wiring	- 42 -
3.8	Control Terminal Specification	- 45 -
3.9	Control Terminal Usage	- 46 -
3.10	Instruction of Signal Switches	- 53 -
3.11	EMI Solutions	- 53 -
Chapter 4	Operation and Run Instructions	- 56 -
4.1	Operation of Control Panel	- 56 -
4.2	First-time Power up	- 72 -
Chapter 5	List of Parameters	- 74 -
Chapter 6	Specification of Parameters	- 121 -
Group A	System Parameters and Parameter Management	- 121 -
Group A0	System Parameters	- 121 -
Group A1	User-defined Display Parameters	- 124 -
Group b	Run Parameter Setting	- 127 -
Group b0	Frequency Setting	- 127 -
Group b1	Start/Stop Control	- 140 -
Group b2	Accel/Decel Parameters	- 146 -
Group C	Input and Output Terminals	- 152 -
Group C0	Digital Input	- 152 -
Group C1	Digital Output	- 165 -
Group C2	Analog and Pulse Input	- 172 -
Group C3	Analog and Pulse Output	- 177 -
Group C4	Automatic Correction of Analog Input	- 182 -
Group d	Motor and Control Parameters	- 183 -
Group d0	Parameters of Motor 1	- 183 -
Group d1	V/f Control Parameters of Motor 1	- 188 -
Group d2	Vector Control Parameters of Motor 1	- 195 -

Group d3	Parameters of Motor 2.....	- 199 -
Group d4	V/f Control Parameters of Motor 2.....	- 200 -
Group d5	Vector Control Parameters of Motor 2.....	- 201 -
Group E	Enhanced Function and Protection Parameters.....	- 203 -
Group E0	Enhanced Function.....	- 203 -
Group E1	Protection Parameters.....	- 207 -
Group F	Application.....	- 211 -
Group F0	Process PID.....	- 211 -
Group F1	Multi-step Frequency.....	- 217 -
Group F2	Simple PLC.....	- 220 -
Group F3	Wobble Frequency and Fixed Length Count.....	- 229 -
Group H	Communication Parameters.....	- 235 -
Group H0	MODBUS Communication Parameters.....	- 235 -
Group H1	Profibus-DP communication parameters.....	- 237 -
Group L	Keys and Display of Control Panel.....	- 237 -
Group L0	Keys of Control Panel.....	- 237 -
Group L1	Control Panel Display Setting.....	- 239 -
Group U	Monitoring.....	- 241 -
Group U0	Status Monitoring.....	- 241 -
Group U1	History Fault.....	- 245 -
Chapter 7	Troubleshooting	- 247 -
7.1	Fault Causes and Troubleshooting.....	- 247 -
Chapter 8	Maintenance	- 255 -
8.1	Routine Inspection.....	- 255 -
8.2	Regular Maintenance.....	- 256 -
8.3	Replacement of Vulnerable Parts.....	- 257 -
8.4	Storage.....	- 258 -

Appendix Communication Protocol	- 260 -
1. Networking Mode.....	- 260 -
2. Interface Mode.....	- 260 -
3. Communication Mode.....	- 260 -
4. Protocol Format.....	- 261 -
5. Protocol Function.....	- 263 -
6. Operation Instructions.....	- 275 -
7. LRC/CRC Generation	- 280 -

Chapter 1 Safety Precautions

Safety Precautions

Safety signs in this manual:

 **WARNING:** indicates the situation in which the failure to follow operating requirements may result in fire or serious personal injury or even death.

 **ATTENTION:** indicates the situation in which the failure to follow operating requirements may cause moderate or slight injury and damage to equipment.

Users are requested to read this chapter carefully when installing, commissioning and repairing this product and perform the operation according to safety precautions as set forth in this chapter without violation. Oxin Drive bears no responsibility for any injury and loss as a result of any violation operation.

1.1 Safety Considerations

1.1.1 Prior to Installation

 WARNING
<ul style="list-style-type: none">• Do not touch control terminals, circuit boards and any other electronic parts and components with bare hands.• Do not use the drive whose component(s) is/are missing or damaged. Failure to comply may result in more faults and/or personal injury even death.

 ATTENTION
<ul style="list-style-type: none">• Check if the product information indicated on the nameplate is consistent with the order requirements. If not, do not install it.• Do not install the drive in the event that the packing list does not match the real equipment.

1.1.2 Installation

 WARNING
<ul style="list-style-type: none">• Only qualified personnel familiar with adjustable frequency AC drives and associated machinery should plan or implement the installation. Failure to comply may result in equipment damage and/or personnel injury even death.

- This equipment must be mounted on metal or other flame retardant objects. Failure to comply may result in fire.
- This equipment must be mounted in an area which is away from combustibles and heat sources. Failure to comply may result in fire.
- This equipment must in no case be mounted in the environment exposed to explosive gases. Failure to comply may result in explosion.
- Never adjust mounting bolts of this equipment, especially the ones with red marks. Failure to comply may result in equipment damage.

**ATTENTION**

- Handle the equipment gently and take hold of its sole plate so as to avoid foot injury or equipment damage.
- Mount the equipment where its weight can be withstood. Failure to comply may result in equipment damage and/or personnel injury if falling happens.
- Make sure the installation environment conforms to the requirements as stated in Section 2.4. If not, de-rating is necessary. Failure to comply may result in equipment damage.
- Prevent drilling residues, wire ends and screws from falling into the equipment during installation. Failure to comply may result in faults or equipment damage.
- When mounted in a cabinet, this equipment should be provided with appropriate heat dissipation. Failure to comply may result in faults or equipment damage.

1.1.3 Wiring**WARNING**

- Only qualified personnel familiar with adjustable frequency AC drives and associated machinery should plan or implement the wiring. Failure to comply may result in personnel injury and/or equipment damage.
- Wiring must strictly conform to this manual. Failure to comply may result in personnel injury and/or equipment damage.
- Make sure the input power supply has been completely disconnected before wiring. Failure to comply may result in personnel injury and/or equipment damage.
- All wiring operations must comply with EMC and safety regulations and/or electrical codes, and the conductor diameter should conform to recommendations of this manual. Failure to comply may result in personnel injury and/or equipment damage.
- Since overall leakage current of this equipment may be bigger than 3.5mA, for safety's sake, this equipment and its associated motor must be well grounded so as to avoid risk of electric shock.

- Be sure to implement wiring in strict accordance with the marks on this equipment's terminals. Never connect three-phase power supply to output terminals U/T1, V/T2 and W/T3. Failure to comply may result in equipment damage.
- Install braking resistors at terminals ⊕ (⊕1) and B2 (BR) only. Failure to comply may result in equipment damage.
- Wiring screws and bolts for main circuit terminals must be screwed tightly. Failure to comply may result in equipment damage.
- AC 220V signal is prohibited from connecting to other terminals than control terminals RA, RB and RC. Failure to comply may result in equipment damage.

**ATTENTION**

- Since all adjustable frequency AC drives from Oxin Drive have been subjected to hi-pot test before delivery, users are prohibited from implementing such a test on this equipment. Failure to comply may result in equipment damage.
- Signal wires should be away from main power lines to the best of the possibility. If this cannot be ensured, vertical cross-arrangement shall be implemented, otherwise interference noise to control signal may occur.
- If motor cables are longer than 100m, it is recommended output AC reactor be used. Failure to comply may result in faults.
- The coder must be provided with shielded cables whose shielded layer must be well grounded.

1.1.4 Run**WARNING**

- Drives which have been stored for more than 2 years should be used with voltage regulator to gradually boost the voltage when applying power to the drives. Failure to comply may result in equipment damage.
- Be sure to implement the wiring as per Section 3.4 before applying power to the drive. Failure to comply may result in equipment damage and/or electric shock hazard.
- Be sure to confirm the completion and correctness of the drive wiring and close the cover before applying power to the drive. Do not open the cover after applying power. Failure to comply may result in electric shock hazard.
- After applying the power, never touch the drive and peripheral circuits no matter what state the drive is under, otherwise there will be electric shock hazard.
- Prior to running the drive, make sure there is no person in surrounding area who can reach the motor so as to prevent personal injury.
- When the drive is running, foreign bodies should be prevented falling into the equipment. Failure to comply may result in faults and/or equipment damage.

- Only qualified technicians familiar with adjustable frequency AC drives are allowed to perform signal test during operation. Failure to comply may result in equipment damage and/or personal injury.
- Never change the drive parameters at will. Failure to comply may result in equipment damage.

**ATTENTION**

- Make sure the number of phases of power supply and rated voltage are consistent with product nameplate. If not, contact the seller or Oxin Drive.
- Check there are no short circuits in peripheral circuits connected with the drive, and make sure the connection is tight. Failure to comply may result in equipment damage.
- Make sure the motor and associated machinery are within allowable range of service prior to operation. Failure to comply may result in equipment damage.
- Never touch fans, heat sink and braking resistor with bare hands. Failure to comply may result in equipment damage and/or personal injury.
- It is not allowed to start & stop the drive frequently via direct switching power on or off. Failure to comply may result in equipment damage.
- Make sure the drive is in a non-output status before switch-on/switch-off of the drive output and/or contactor. Failure to comply may result in equipment damage.

1.1.5 Maintenance**WARNING**

- Only qualified technicians are allowed to implement the maintenance, and troubleshooting.
- Never implement the maintenance, and troubleshooting before power supply has been turned off and discharged completely. Failure to comply may result in equipment damage and/or personal injury.
- To avoid an electric shock hazard, wait at least 10 minutes after the power has been turned off and make sure the residual voltage of the bus capacitors has discharged to 0V before performing any work on the drive.
- After the replacement of the drive, be sure to perform the same procedures in strict accordance with the above-noted rules.

**ATTENTION**

- Do not touch the electric components with bare hands during maintenance, and troubleshooting. Failure to comply may result in component damage due to ESD.
- All pluggable components can be inserted or pulled out only when power has been turned off.

1.2 Other Considerations

1.2.1 Input Power Supply

This series of drives are not applicable to applications out the range of operating voltage as set forth in this manual. If necessary, please use booster to rise or drop the voltage to regulated voltage range.

This series of drives support common DC bus input. Users are suggested to consult Oxin Drive technical personnel before use.

1.2.2 Surge Protection

This series of drives are furnished with surge suppressor that has certain resistance to lightning induction. However, users in areas where lightning occurs frequently need to mount an external surge suppressor in front of power input side of the drive.

1.2.3 Operation of Contactor

As to the configuration of peripheral devices recommended by this manual, it is necessary to mount a contactor between the power supply and input side of the drive. Such a contactor should not be used as a control device to start and stop the drive, as frequent charging & discharging shall reduce the service life of internal electrolytic capacitors.

When it is necessary to mount a contactor between the drive output and the motor, it should be ensured the drive is in a non-output status before switch-on/switch-off of such a contactor. Failure to comply may result in damage to the drive.

1.2.4 Output Filter

Since the drive output is PWM high frequency chopping voltage, mounting filter devices such as an output filter and an output AC reactor between the motor and the drive shall effectively reduce output noise, avoiding interference to other surrounding equipment.

If the length of cable between the drive and the motor exceeds 100m, an output AC reactor is recommended to use with the purpose of preventing drive fault as a result of overcurrent caused by excessive distributed capacitance. An output filter is optional depending on the field requirements.

Be sure not to mount phase-shifting capacitor or surge absorber at output side of the drive since this may cause damage to the drive as a result of over-temperature.

1.2.5 Insulation of the Motor

In view of the fact that the drive output is PWM high frequency chopping voltage accompanied by higher harmonics, the noise, temperature rise and vibration of the motor is higher compared with sinusoidal voltage. Particularly this debases motor insulation. Therefore, the motor should be subjected to insulation inspection before initial use or reuse after being stored for a long period of time. The motor in regular service should also be subjected to regular insulation inspection so as to avoid damage to the drive as a result of motor insulation damage. A 500V voltage mode mega-ohmmeter is recommended to use for the measurement of the motor insulation, during which, it is essential to disconnect the motor from the drive. Normally, the insulation resistance of the motor should be bigger than $5M\Omega$.

1.2.6 Derating

Due to the thin air in high-altitude areas, the radiating performance of the drive with forced air cooling may degrade while the electrolyte of electrolytic capacitors is more volatile, which can result in reduction in product life. Drive should be derated when used in an area at the altitude above 1000 meters. It is recommended to derate 1% for every 100m when the altitude is above 1000 meters.

Chapter 2 Product Information

2.1 Model Explanation

Model shown on product nameplate indicates the series name, applicable type of power supply, power class and the version of software and hardware, etc. via the combination of numbers, symbols and letters.

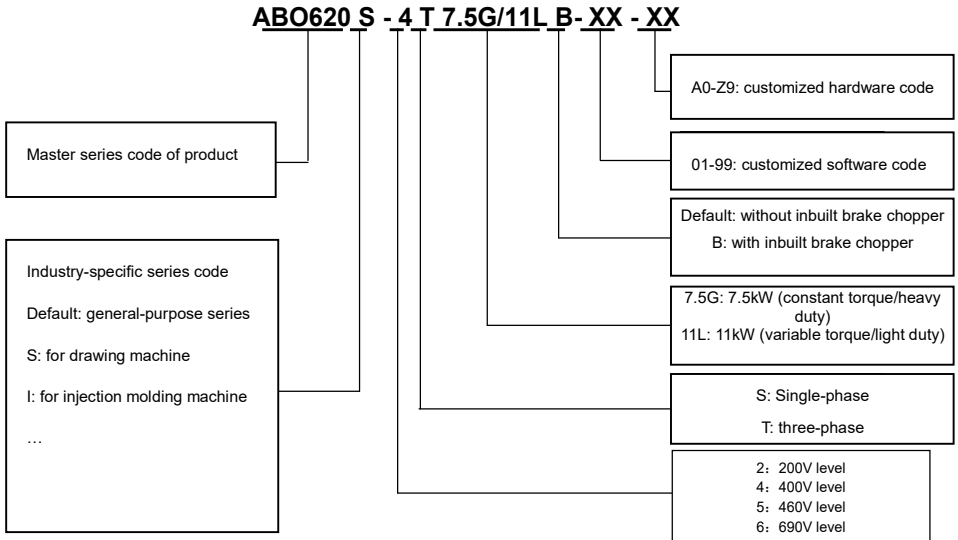

Fig. 2-1 Product model explanation

2.2 Nameplate Information

2.3 Information of Product Model

Table 2-1 Product model and technical data

- ABO620-2T□□□B, single/ three-phase 220V input, heavy duty

Drive model	Power rating (kW)	3-phase rated output current (A)	1-phase rated input current (A)	3-phase rated input current (A)	Applicable motor (kW)	Brake chopper
ABO620-2T0.4B	0.4	2.6	5.5	3.2	0.4	Inbuilt
ABO620-2T0.75B	0.75	4.5	9.2	6.3	0.75	
ABO620-2T1.5B	1.5	7.5	14.5	9	1.5	
ABO620-2T2.2B	2.2	11	23	15	2.2	

- ABO620-2T□□□□, three-phase 220V input, heavy duty

Drive model	Power rating (kW)	3-phase rated output current (A)	3-phase rated input current (A)	Applicable motor (kW)	Brake chopper
ABO620-2T3.7B	3.7	16.5	20.5	3.7	Inbuilt
ABO620-2T5.5B	5.5	24	29	5.5	
ABO620-2T7.5B	7.5	30	35	7.5	
ABO620-2T11(B)	11	45	50	11	Inbuilt optional
ABO620-2T15(B)	15	60	65	15	
ABO620-2T18.5(B)	18.5	73	80	18.5	
ABO620-2T22(B)	22	91	95	22	
ABO620-2T30(B)	30	112	118	30	
ABO620-2T37(B)	37	144	150	37	
ABO620-2T45	45	176	160	45	Externally mounted when needed
ABO620-2T55	55	210	192	55	
ABO620-2T75	75	288	266	75	
ABO620-2T90	90	350	326	90	
ABO620-2T110	110	430	403	110	

■ ABO620-4T□□□G/□□□L□, three-phase 400V input, heavy duty/ light duty

Drive model		Power rating (kW)	Rated output current (A)	Rated input current (A)	Applicable motor (kW)	Brake chopper	DC reactor
ABO620-4T0.75G/1.5LB	0.75G	0.75	2.5	3.5	0.7	Inbuilt	/
	1.5L	1.5	3.8	5.0	1.5		
ABO620-4T1.5G/2.2LB	1.5G	1.5	3.8	5.0	1.5		
	2.2L	2.2	4.8	5.5	2.2		
ABO620-4T2.2G/3.7LB	2.2G	2.2	5.5	6.0	2.2		
	3.7L	3.7	8.0	10	3.7		
ABO620-4T3.7G/5.5LB	3.7G	3.7	9.0	10.5	3.7		
	5.5L	5.5	11	14	5.5		
ABO620-4T5.5G/7.5LB	5.5G	5.5	13	14.6	5.5		
	7.5L	7.5	16	20	7.5		
ABO620-4T7.5G/11LB	7.5G	7.5	17	20.5	7.5		
	11L	11	21	25	11		
ABO620-4T11G/15LB	11G	11	24	29	11		
	15L	15	30	35	15		
ABO620-4T15G/18.5LB	15G	15	30	35	15		
	18.5L	18.5	36	40	18.		
ABO620-4T18.5G/22LB	18.5G	18.5	39	44	18.		
	22L	22	45	50	22		
ABO620-4T22G/30LB	22G	22	45	50	22		
	30L	30	56	60	30		
ABO620-4T30G/37L(B/D/H)	30G	30	60	65	30	Inbuilt optional	Inbuilt optional
	37L	37	72	76	37		
ABO620-4T37G/45L(B/D/H)	37G	37	75	80	37		
	45L	45	91	95	45		
ABO620-4T45G/55LD(H)**	45G	45	91	95	45	Inbuilt optional	Inbuilt
	55L	55	112	118	55		
ABO620-4T55G/75LD(H)**	55G	55	112	118	55		
	75L	75	142	148	75		
ABO620-4T75G/90L(B)*	75G	75	150	157	75	/	
	90L	90	176	180	90		

Drive model		Power rating (kW)	Rated output current (A)	Rated input current (A)	Applicable motor (kW)	Brake chopper	DC reactor
ABO620-4T90G/110L	90G	90	176	160***	90	External when needed	External when needed
	110L	110	210	192***	110		
ABO620-4T110G/132L	110G	110	210	192***	110		
	132L	132	250	230***	132		
ABO620-4T132G/160L	132G	132	253	232***	132		
	160L	160	304	280***	160		
ABO620-4T160G/185L	160G	160	310	285***	160		
	185L	185	350	326***	185		
ABO620-4T185G/200L	185G	185	350	326***	185		
	200L	200	380	354***	200		
ABO620-4T200G/220L	200G	200	380	354***	200		
	220L	220	430	403***	220		
ABO620-4T220G/250L	220G	220	430	403***	220		
	250L	250	470	441***	250		
ABO620-4T250G/280L	250G	250	470	441***	250		
	280L	280	520	489***	280		
ABO620-4T280G/315L	280G	280	520	489***	280		
	315L	315	590	571***	315		
ABO620-4T315G/355L	315G	315	590	571***	315		
	355L	355	650	624***	355		
ABO620-4T355G/400L	355G	355	650	624***	355		
	400L	400	725	699***	400		
ABO620-4T400G/450L	400G	400	725	699***	400		
	450L	450	820	790***	450		
ABO620-4T450G/500L	450G	450	820	790***	450		
	500L	500	860	835***	500		
ABO620-4T500G	500G	500	860	835***	500		
ABO620-4T560G	560G	560	950	920***	560		
ABO620-4T630G	630G	630	1100	1050***	630	Inbuilt	

* means brake chopper and DC reactor are optionally inbuilt (for ABO620-4T75G/90L(B), only bake chopper is optionally inbuilt). Take 30G/37L for example: the model without brake chopper and DC reactor is ABO620-4T30G/37L, the model with brake chopper is ABO620-4T30G/37LB, the model with DC reactor is ABO620-4T30G/37LD, and the model with brake chopper and DC reactor is ABO620-4T30G/37LH. Braking resistor needs to be mounted externally with reference to 3.4.3.

** means DC reactor is inbuilt, and brake chopper is optionally inbuilt. Take 45G/55L for example: the model with DC reactor is ABO620-4T45G/55LD, and the model with DC reactor and brake chopper is ABO620-4T45G/55LH. Braking resistor needs to be mounted externally with reference to 3.4.3

*** means the rated input current configured a DC reactor. The drive ABO620-4T90G/110L - ABO620-4T500G is provided with an external-mounted DC reactor in shipment as default. Be sure to connect the DC reactor. Failure to comply may result in drive abnormal run. ABO620-4T560G and ABO620-4T630G are cabinet type, whose DC reactor and output AC reactor are inbuilt as default

2.4 Technical Features of ABO620

Table 2-2 Technical Features of ABO620

Power input	Rated input voltage	3-phase AC208V//AC220V//AC230V//AC240V//AC380V//AC400V// AC415V//AC440V 1-phase AC220V//AC230V//AC240V
	Frequency	50Hz/60Hz, tolerance $\pm 5\%$
	Voltage range	Continuous voltage fluctuation $\pm 10\%$, short fluctuation $-15\% \sim +10\%$, i.e. 200V: 170V~264V, 400V: 323V~484V
		Voltage out-of-balance rate $< 3\%$, distortion rate as per the requirements of IEC61800-2
Rated input current	See Section 2.3	
Power output	Applicable motor (kW)	See Section 2.3
	Rated current (A)	See Section 2.3
	Output voltage (V)	3-phase: 0~ rated input voltage, error $< \pm 3\%$
	Output frequency (Hz)	0.00~ 600.00Hz; unit: 0.01Hz
	Overload capacity	150% - 1min, 180% - 10s, 200% - 0.5s every 10 min

Control characteristics	V/f patterns	V/f control Sensor-less vector control 1 Sensor-less vector control 2 Synchronous motor sensor-less vector control
	Range of speed regulation	1:100 (V/f control, sensor-less vector control 1) 1:200 (sensor-less vector control 2, synchronous motor sensor-less vector control)
Control characteristics	Speed accuracy	±0.5% (V/f control) ±0.2% (sensor-less vector control 1 & 2, synchronous motor sensor-less vector control)
	Speed fluctuation	±0.3% (sensor-less vector control 1 & 2, synchronous motor sensor-less vector control)
	Torque response	< 10ms (sensor-less vector control 1 & 2, synchronous motor sensor-less vector control)
	Starting torque	0.5Hz: 180% (V/f control, sensor-less vector control 1) 0.25Hz: 180% (sensor-less vector control 2, synchronous motor sensor-less vector control)
Basic functions	Start frequency	0.00~ 600.00Hz
	Accel/Decel time	0.00~60000s
	Switching frequency	0.7kHz~16kHz
	Frequency setting	Digital setting + control panel \wedge/\vee Digital setting + terminal UP/DOWN Communication Analog setting (AI1/AI2/EAI) Terminal pulse setting
	Motor start-up methods	Started from starting frequency DC brake start-up Flying start
	Motor stop methods	Ramp to stop Coast to stop Ramp stop + DC brake
Basic functions	Dynamic braking capacity	Brake chopper working voltage: 400V level: 650V-750V Service time: 0-100.0s; brake chopper for ABO620-4T55G/75L and below are inbuilt or can be inbuilt optionally. See table 2-1
	DC brake capacity	DC brake start frequency: 0.00~600.00Hz DC brake current: 0.0~100.0% DC brake time: 0.0~30.00s

	Input terminals	6 digital inputs, one of which can be used for high-speed pulse input, and compatible with active open collectors NPN, PNP and dry contact input. Digital inputs can be extended to 7 2 analog inputs, one of which is voltage/current programmable, and the other supports voltage only. Analog inputs can be extended to 3, and the extended one is voltage/current programmable
Basic functions	Output terminals	1 high-speed pulse output, 0~50kHz square wave signal output. It can output signals such as frequency setting, or output frequency, etc. 1 digital output 1 relay output (can be extended to 2) 1 analog output (can be extended to 2), voltage/current output programmable; can output signals such as frequency setting, or output frequency, etc.
Featured functions	Parameter copy, parameter backup, common DC bus, free switchover between two motors' parameters, flexible parameter displayed & hidden, various master & auxiliary setting and switchover, flying start, a variety of Accel/Decel curves optional, automatic correction of analog, brake control, 16-step speed control programmable (2-step speed supports flexible frequency command), wobble frequency control, fixed length control, count function, three history faults, over excitation brake, over voltage stall protection, under voltage stall protection, restart on power loss, skip frequency, frequency binding, four kinds of Accel/Decel time, motor thermal protection, flexible fan control, process PID control, simple PLC, multi-functional key programmable, droop control, autotuning, field-weakening control, high-precision torque restraint, V/f separated control	
Protection functions	Refer to Chapter 7- Troubleshooting	
Environment	Place of operation	Indoors, no direct sunlight, free from dust, corrosive gases, flammable gases, oil mist, water vapor, water drop or salt, etc.
	Altitude	0-2000m. De-rate 1% for every 100m when the altitude is above 1000 meters
	Ambient temperature	-10℃-40℃. The rated output current should be derated 1% for every 1℃ when the ambient is 40℃-50℃
	Relative humidity	0~95%, no condensation
	Vibration	Less than 5.9m/s ² (0.6g)
	Storage temperature	-40℃~+70℃

Others	Efficiency at rated Amps	Rated power 7.5kW and below: $\geq 93\%$ 11~ 45kW: $\geq 95\%$ 55kW and above: $\geq 98\%$
	Installation	Wall-mounted
	IP grade	IP20
	Cooling method	Forced air cooling

2.5 Parts Drawing

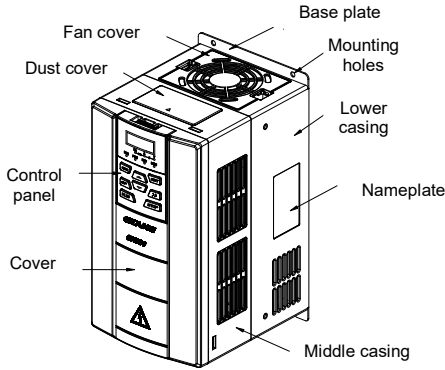

a) ABO620-4T22G/30LB and below

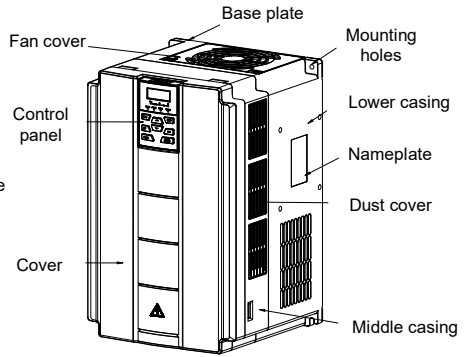

b) ABO620-4T30G/37L(B/D/H)
ABO620-4T37G/45L(B/D/H)

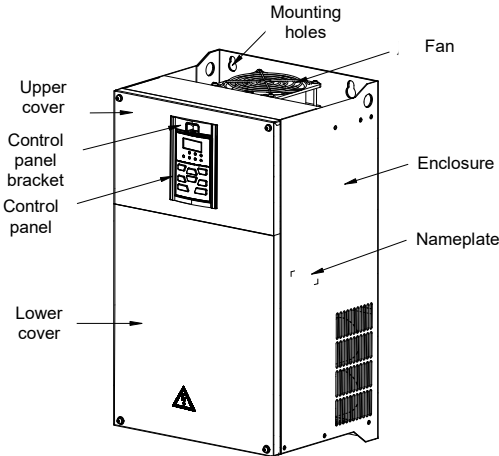

c)
ABO620-4T45G/55LD(H)~
ABO620-4T55G/75LD(H)

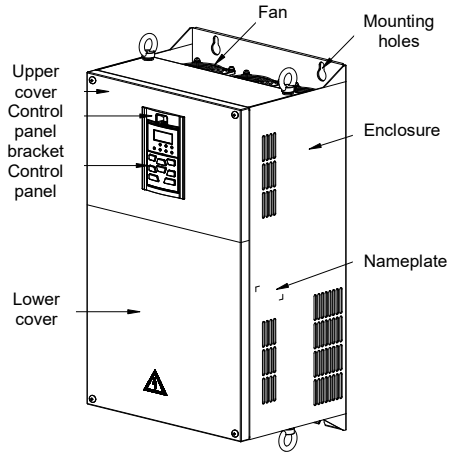

d) ABO620-4T75G/90L(B)

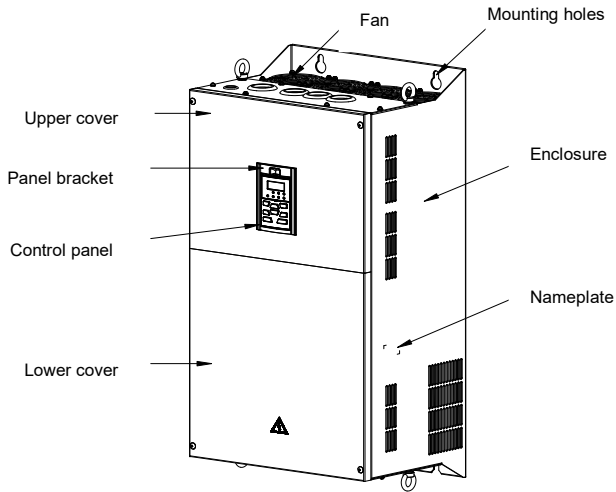

e) ABO620-4T90G/110L~ ABO620-4T500G

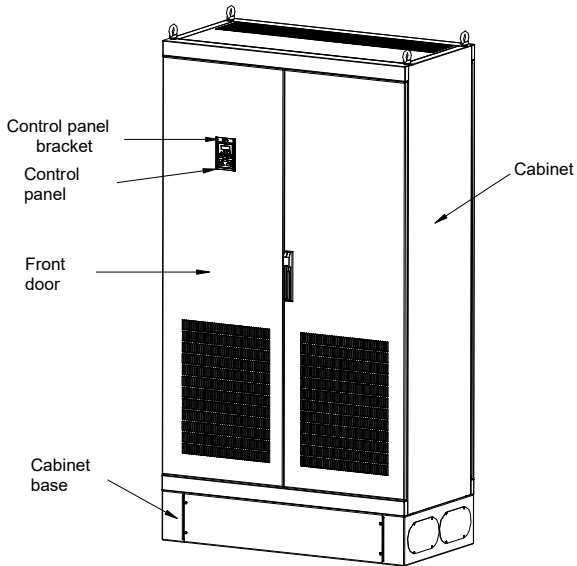

f) ABO620-4T560G and ABO620-4T630G

Fig. 2-3 Parts drawing

2.6 Appearance, Mounting Dimensions and Weight

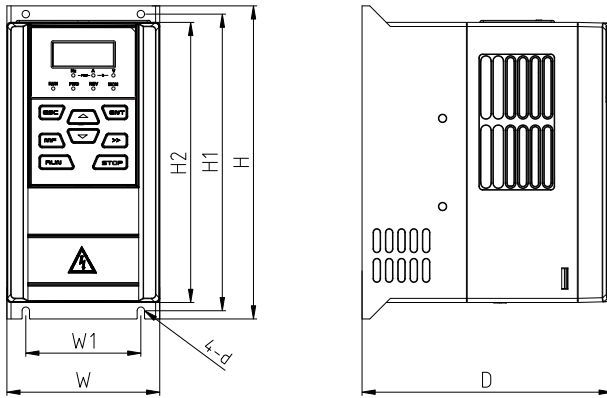

a) ABO620-4T0.75G/1.5LB ~ ABO620-4T3.7G/5.5LB

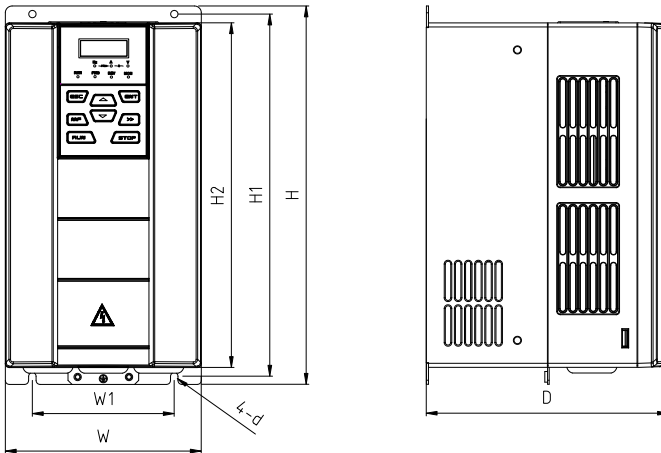

b) ABO620-4T5.5G/7.5LB ~ ABO620-4T22G/30LB

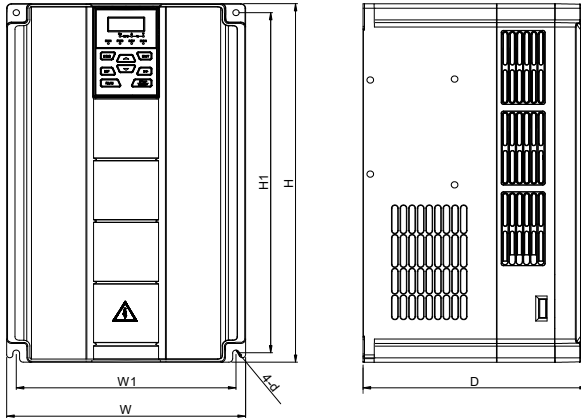

c) ABO620-4T30G/37L(B/D/H) ~ ABO620-4T37G/45L(B/D/H)

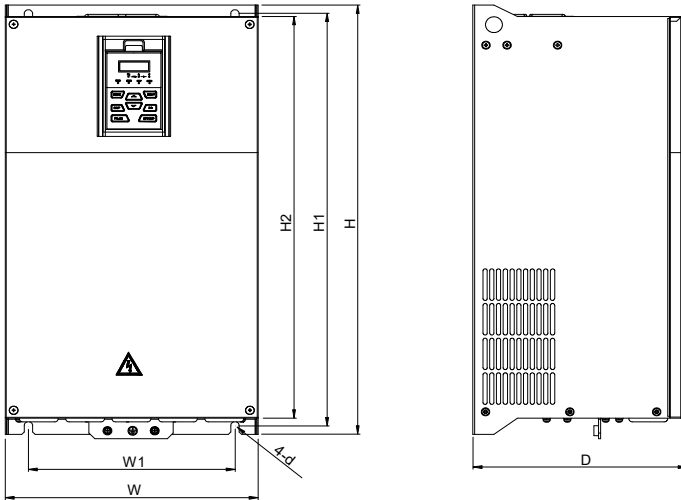

d) ABO620-4T45G/55LD(H) ~ ABO620-4T55G/75LD(H)

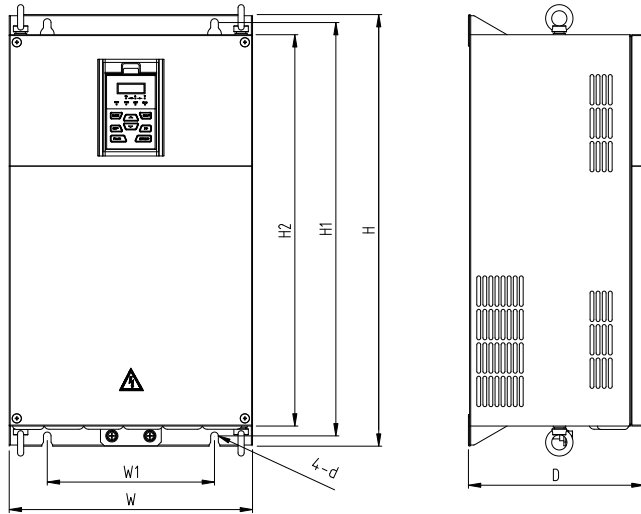

e) ABO620-4T75G/90L(B)

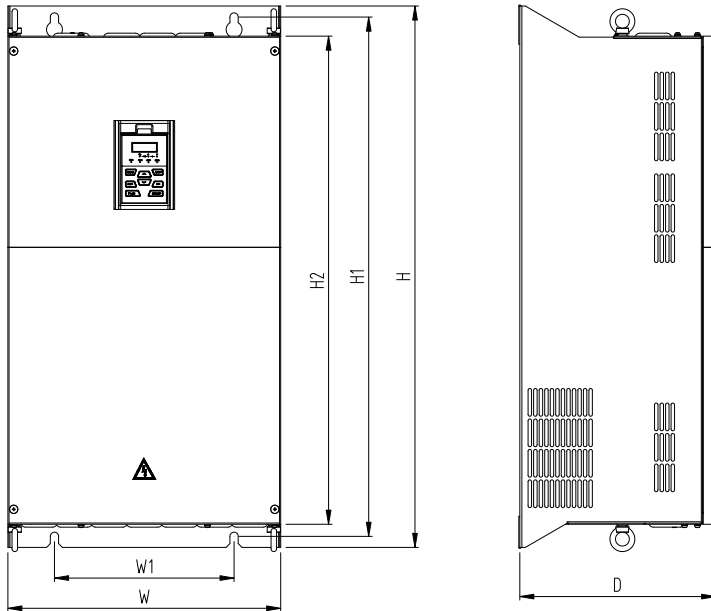

f) ABO620-2T90 ~ ABO620-4T160G/185L

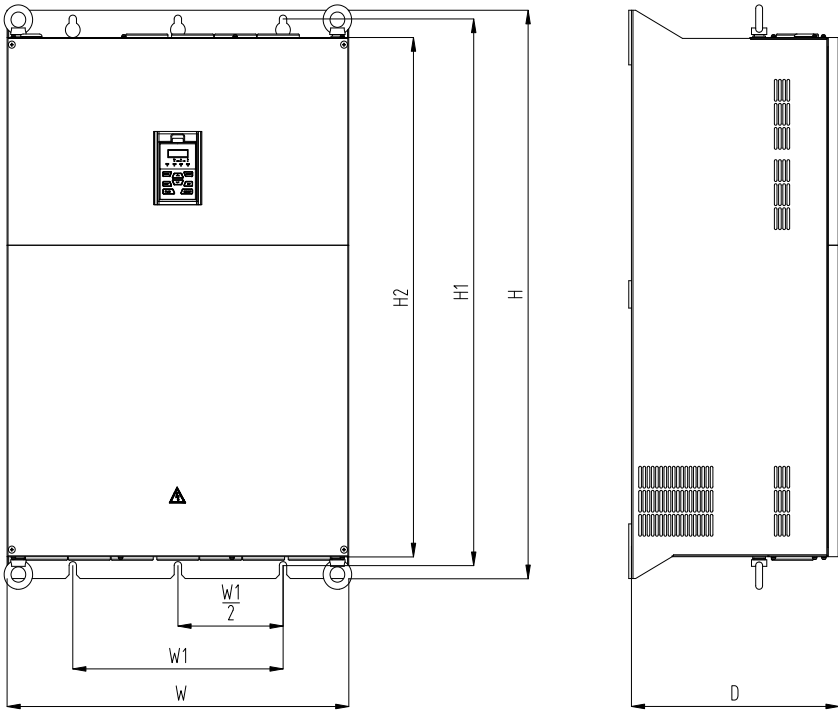

g) ABO620-4T185G/200L ~ ABO620-4T500G

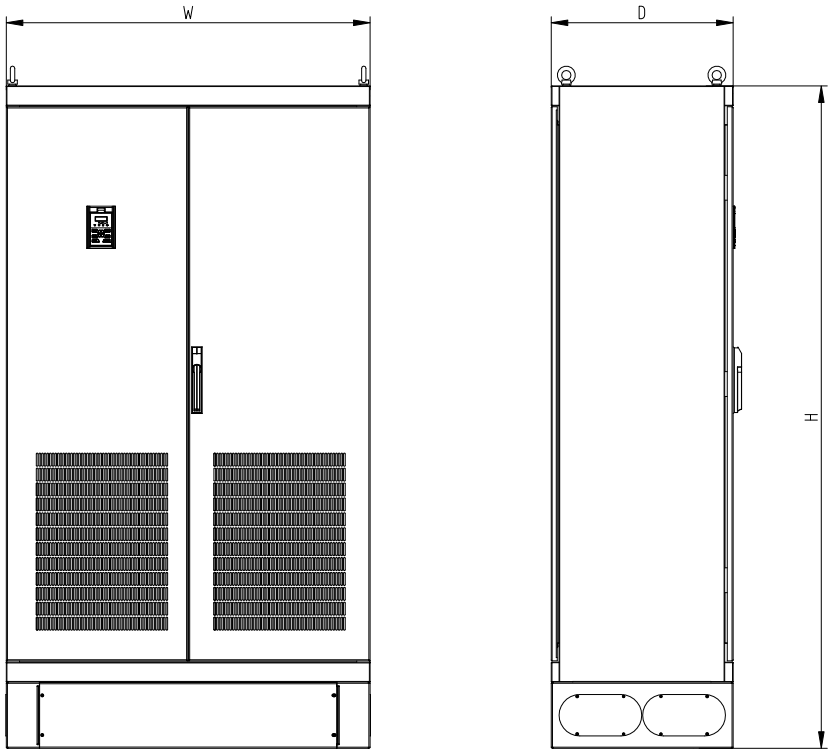

h) ABO620-4T560G ~ ABO620-4T630G

Fig. 2-4 External dimensions

Table 2-3 Appearance, mounting dimensions and weight

Model	External and installation dimensions (mm)							Weight (kg)
	W	H	D	W1	H1	H2	Mounting hole dia.	
ABO620-4T0.75G/1.5LB	93	190	152	70	180	172	4.5	1.4
ABO620-4T1.5G/2.2LB								
ABO620-4T2.2G/3.7LB								
ABO620-4T3.7G/5.5LB								
ABO620-4T5.5G/7.5LB	120	245	169	80	233	220	5.5	2.9
ABO620-4T7.5G/11LB								
ABO620-4T11G/15LB	145	280	179	105	268	255	5.5	3.9
ABO620-4T15G/18.5LB	190	365	187	120	353	335	6	6.2
ABO620-4T18.5G/22LB								
ABO620-4T22G/30LB								
ABO620-4T30G/37L(B)	270	510	270					
ABO620-4T37G/45L(B)								
ABO620-4T30G/37LD(H)	270	510	270					
ABO620-4T37G/45LD(H)								
ABO620-4T45G/55LD(H)	310	730	310					
ABO620-4T55G/75LD(H)								
ABO620-4T75G/90L(B)								
ABO620-4T90G/110L	372	960	357					
ABO620-4T110G/132L								
ABO620-4T132G/160L								
ABO620-4T160G/185L	432	1200	360					
ABO620-4T185G/200L								
ABO620-4T200G/220L	440	1210	345					
ABO620-4T220G/250L								
ABO620-4T250G/280L	690	1250	350					
ABO620-4T280G/315L								
ABO620-4T315G/355L	690	1250	345					
ABO620-4T355G/400L	935	1250	345					
ABO620-4T400G/450L								
ABO620-4T450G/500L								
ABO620-4T500G	960	1250	420					
ABO620-4T560G								
ABO620-4T630G	1100	2000	550					

2.7 External Dimensions of Control Panel

Control panel model of ABO620 series general purpose AC motor drive is BX1 whose appearance and external dimensions are shown in Fig. 2-5.

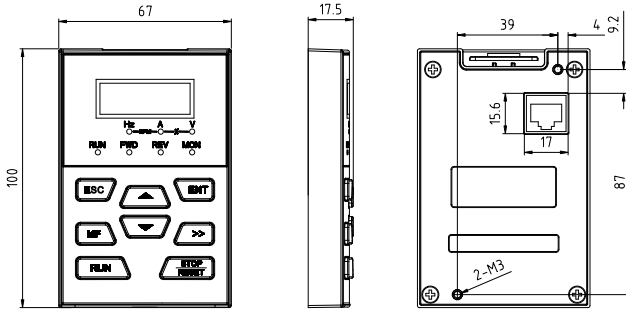
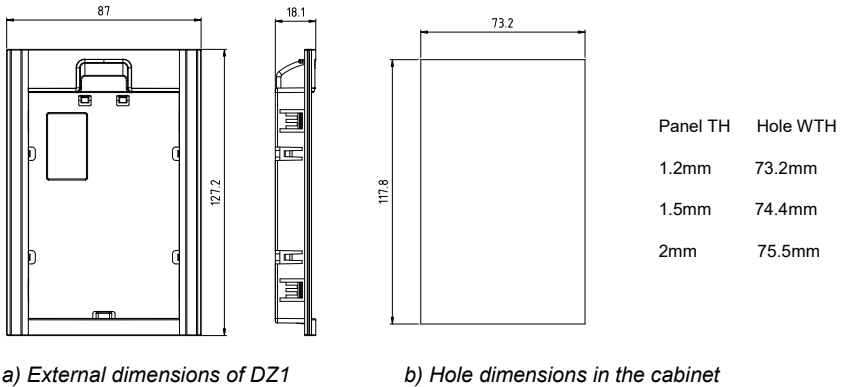

Fig. 2-5 External dimensions of BX1

2.8 External Dimensions of Control Panel Bracket

A bracket should be provided to support the panel and a hole in the cabinet needs to be opened when the control panel BX1 needs to be remotely used. Bracket model is DZ1 whose external dimensions are shown in Fig. 2-6 a). Fig. 2-6 b) shows applicable hole dimensions in the cabinet.



a) External dimensions of DZ1

b) Hole dimensions in the cabinet

Fig. 2-6 External dimensions of DZ1 and cabinet hole dimensions

Chapter 3 Installation and Wiring

3.1 Installation Environment

- 1) Ambient temperature is in the range of -10°C to 40°C .
- 2) Drive should be installed on surface of flame retardant object, with adequate surrounding space for heat dissipation.
- 3) Installation should be performed where vibration is less than 5.9m/s^2 (0.6g).
- 4) Protect from moisture and direct sunlight.
- 5) Protect the cooling fan by avoiding oil, dust and metal particles.
- 6) Do not expose to an atmosphere with flammable gases, corrosive gases, explosive gases or other harmful gases.
- 7) Prevent drilling residues, wire ends and screws falling into drive.
- 8) Ventilation part of the drive should be installed outside from harsh environment (e.g. textile facilities with fiber particles and chemical facilities filled with corrosive gases).

3.2 Minimum Mounting Clearances

To ensure favorable heat dissipation, mount the drive upright on a flat, vertical and level surface as per Fig. 3.1. For installation inside cabinet, the product shall be mounted side by side to the greatest extent while adequate surrounding space shall be preserved for favorable heat dissipation.

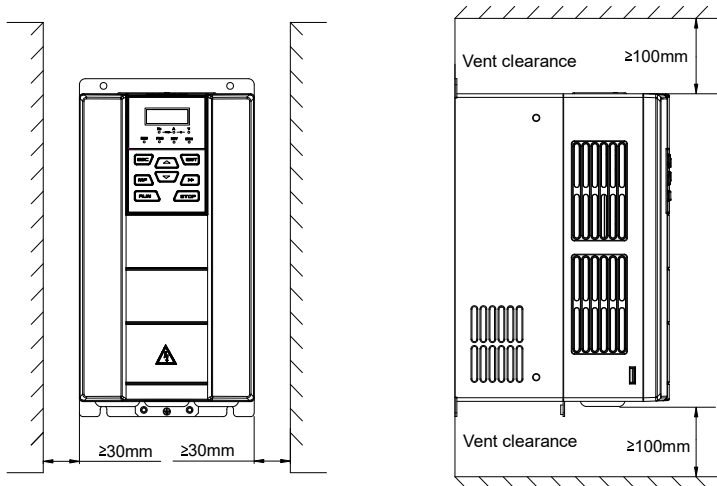

Fig. 3-1 Minimum mounting clearances of ABO620-4T22G/30LB and below

ATTENTION:

Remove dust covers when mounting a drive ABO620-4T22G/30LB or below. If several drives are mounted in one cabinet, parallel side-by-side mounting is recommended.

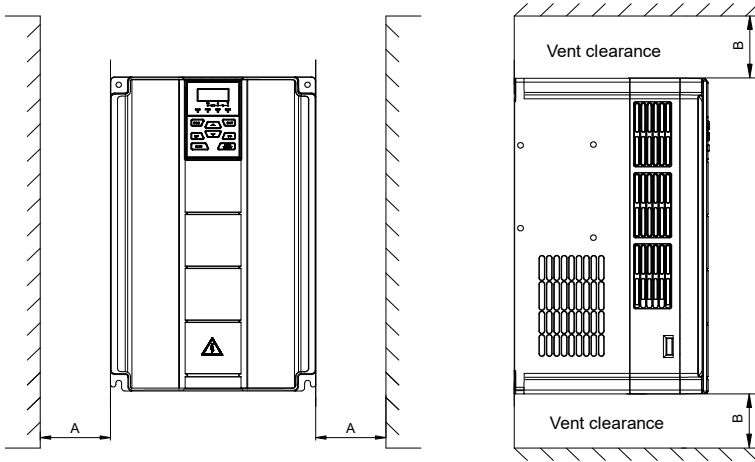

Fig. 3-2 Minimum mounting clearances of ABO620-4T30G/37L(B/D/H)~ 4T37G/45L(B/D/H)

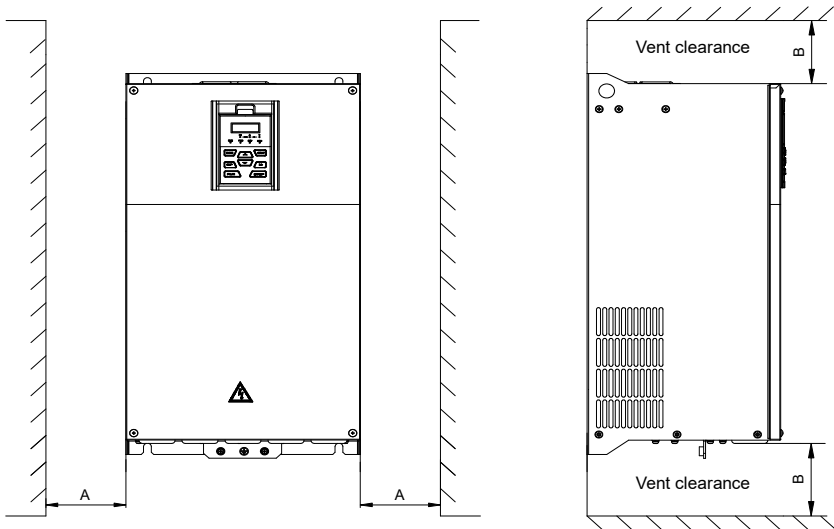

Fig. 3-3 Minimum mounting clearances of ABO620-4T45G/55LD(H)~ ABO620-4T55G/75LD(H)

ATTENTION:

When mounting a drive ABO620-4T30G/37L(B/D/H) or above, the minimum mounting clearances as set forth in Table 3-1 should be assured. In case several drives are mounted in one cabinet, parallel side-by-side mounting is recommended.

Table 3-1 Requirement of minimum mounting clearances

Drive model	Mounting clearances (mm)	
	A	B
ABO620-4T30G/37L(B/D/H) ~ ABO620-4T37G/45L(B/D/H)	≥50	≥200
ABO620-4T45G/55LD(H) ~ ABO620-4T500G	≥50	≥300

3.3 Remove & Mount Control Panel and Cover**3.3.1 Remove and Mount Control Panel**

- Remove control panel

Press the buckle of control panel as indicated by number "1" in Fig. 3-4, then pull the panel out to release as indicated by "2".

- Mount control panel

Slightly slant the panel in the direction as indicated by number "1" in Fig. 3-5 and align it to clamping port at lower part of panel bracket, then press it in as indicated by "2". When a "click" sound heard, it indicates clamping has been properly made.

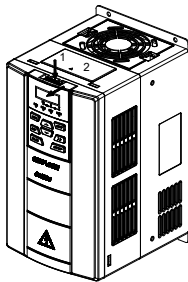
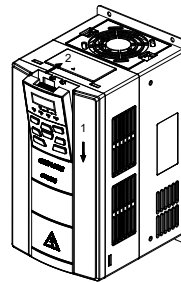
*Fig. 3-4 Remove the control panel**Fig. 3-5 Mount the control panel***3.3.2 Open & Mount the Covers of ABO620-4T22G/30LB and below**

- Remove the control panel

Use the remove method as stated in Section 3.3.1.

- **Open the cover**

Method 1: loosen the captive cover screws as shown in Fig. 3-6 a) (provided only for 15/18.5/22kW model), hold the left and front sides of middle housing with left hand, put the right thumb into the buckle and press tightly on cover with the other four fingers, pull the lower part of the cover out to release, as indicated by number "2".

Method 2: loosen the captive cover screws, as indicated by number "1" in Fig. 3-6 b) (provided only for 15/18.5/22kW model), use a sizeable slotted screwdriver to push the buckle slightly at the lower part of the cover to make buckle naturally off the groove, as indicated by number "2", pull the cover out to release, as indicated by number "3".

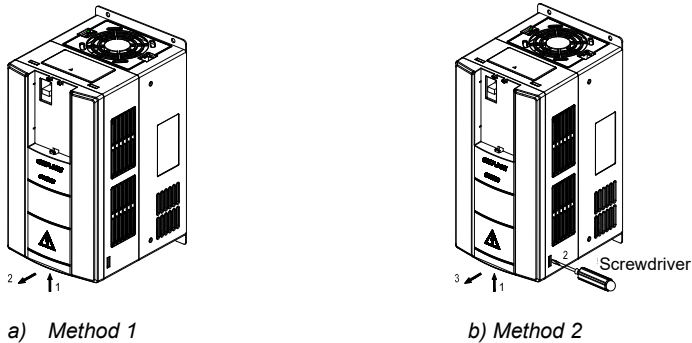

Fig. 3-6 Open the cover

- **Mount the cover**

On the completion of wiring, insert the buckle at higher part of the cover into the grooves at middle housing as indicated by number "1" in Fig. 3-7, then push in the lower part of the cover as indicated by number "2". When a "click" sound heard, it indicates clamping has been properly made. Tighten the screws (provided only for 15/18.5/22kW model) in buckle grooves as finish.

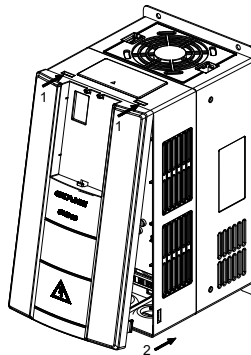

Fig. 3-7 Mount the cover

- **Mount the control panel**

Use the mounting method as stated in Section 3.3.1.

 **ATTENTION:**

Be sure to remove the control panel before opening the cover and mount the cover before mounting the control panel.

3.3.3 Open & Mount the Covers of ABO620-4T30G/37L(B/D/H)~ ABO620-4T37G/45L(B/D/H)

- **Remove the control panel**

Use the remove method as stated in Section 3.3.1.

- **Open cover**

Use a sizeable slotted screwdriver to push the buckle(on both sides) slightly at the lower part of the cover to make buckle naturally off the groove, as indicated by "2" in Fig. 3-8, pull the cover out to release, as indicated by number "3"..

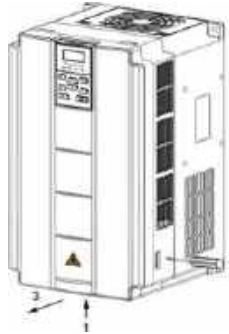

Fig. 3-8 Open cover

- **Mount cover**

On the completion of wiring, insert the buckle at higher part of the cover into the grooves at middle housing as indicated by number "1" in Fig. 3-9, then push in the lower part of the cover as indicated by "2". When a "click" sound heard, it indicates clamping has been properly made, as cover mounting finish.



Fig. 3-9 Mount cover

- **Mount the control panel**

Use the mounting method as stated in Section 3.3.1.

 **ATTENTION:**

Be sure to remove the control panel before opening the cover and mount the cover before mounting the control panel.

3.3.4 Open & Mount the Covers of ABO620-4T45G/55LD(H) and above

- **Remove the control panel**

Use the remove method as stated in Section 3.3.1.

- **Open the lower cover**

Loosen the two captive cover screws at lower part of the lower cover by using cross screwdriver, as indicated by number "1" as shown in Fig. 3-10 (left), then pull the cover out and up as indicated by number "2".

- **Open the upper cover**

Loosen the two captive cover screws at lower part of the lower cover by using cross screwdriver, as indicated by number "3" and "4" as shown in Fig. 3-10 (right), then pull the cover out and up as indicated by number "5".

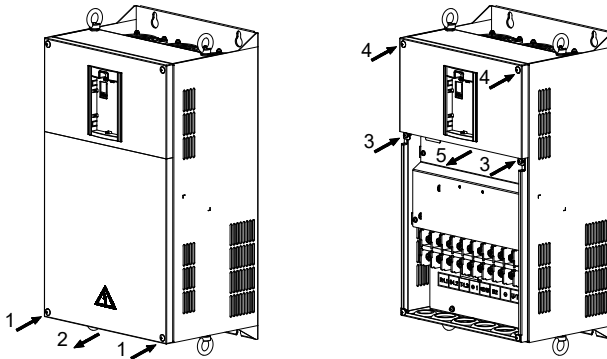

Fig. 3-10 Open the lower and upper cover

- **Mount the upper cover**

Insert the upper part of the cover into mounting groove as shown in Fig. 3-11 (left), close the upper cover, use cross screwdriver to tighten the four captive screws, as indicated by number "1" and "2".

- **Mount the lower cover**

Insert the lower cover into upper cover in the direction as indicated by number 3 in Fig. 3-11 (right), close the lower cover and tighten the two captive screws, as indicated by number "4".

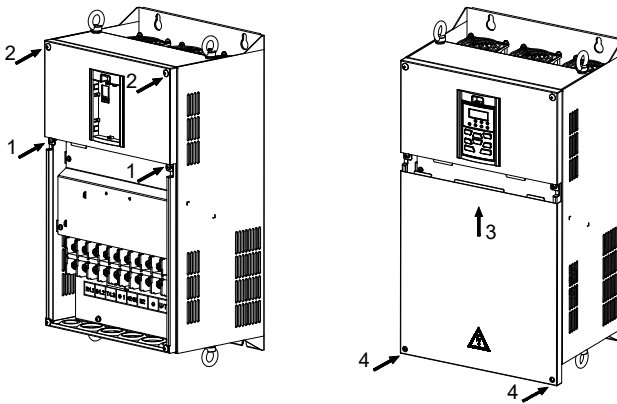

Fig. 3-11 Mount the upper and lower covers

- **Mount the control panel**

Use the mounting method as stated in Section 3.3.1.

 **ATTENTION:**

Be sure to remove the control panel before opening the cover and mount the cover before mounting the control panel.

3.4 Configuration of Peripheral Devices

3.4.1 Standard Configuration of Peripheral Devices

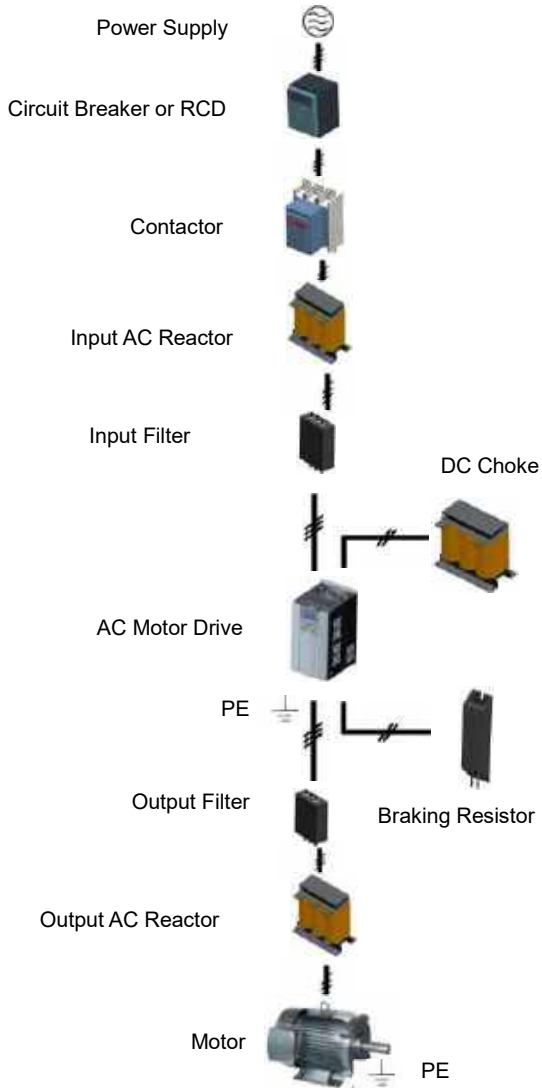

Fig. 3-12 Standard configuration of peripheral devices

3.4.2 Instructions for Peripheral Devices

Table 3-2 Instructions for peripheral devices

Name	Instructions
Power supply	Input three-phase AC power supply should be in the range as specified in this manual
Circuit breaker	Purpose: disconnect power supply and protect the equipment in case of abnormal overcurrent occurs Type selection: breaking current of circuit breaker is defined to be 1.5~2 times the rated current of the drive Breaking time characteristic of circuit breaker should be selected based on overload protection time characteristic of the drive
RCD	Purpose: since the drive outputs PWM HF chopping voltage, HF leakage current is inevitable Type selection: type B dedicated RCD is recommended
Contactor	For safety's sake, do not frequently close and break the contactor since this may bring about equipment faults Do not control the start & stop of the drive directly through switch on and off the contactor since this will result in a reduction on the product life
Input AC reactor or DC choke	Improve power factor Reduce the impact of imbalanced three-phase input AC power supply on the system Suppress higher harmonics and reduce the conducted and radiated interference to peripheral devices Restrict the impact of impulse current on rectifier bridges
Input filter	Reduce conducted interference from power supply to the drive, improve the immunity of the drive from noise Reduce conducted and radiated interference of the drive to peripheral devices
Brake unit and braking resistor	Purpose: consume motor feedback energy to attain quick brake Type selection: Contact Oxin Drive technical personnel for type selection of brake unit. Refer to type selection of braking resistor in Table 3-3 Type Selection of Peripheral Devices.
Output filter	Reduce conducted and radiated interference of the drive to peripheral devices
Output AC reactor	Avoid the motor insulation damage result from harmonic voltage Reduce frequent protection from the drive caused by leakage current In case the cable connecting drive and motor is over 100 meters, output AC reactor recommended
Motor	Should match the drive

3.4.3 Selection of Peripheral Devices

Table 3-3 Selection of peripheral devices

■ABO620-4T□□□G/□□□L□, Three phase 400V input

Drive model		Circuit breaker (A)	Contactor (A)	Brake resistor /Brake chopper*	
				Power (W)	Resistance (Ω)
ABO620-4T0.75G/1.5LB	0.75G	10	9	150	≥135
	1.5L	10	9		
ABO620-4T1.5G/2.2LB	1.5G	10	9	300	≥135
	2.2L	10	9		
ABO620-4T2.2G/3.7LB	2.2G	10	9	400	≥100
	3.7L	16	12		
ABO620-4T3.7G/5.5LB	3.7G	16	12	500	≥67
	5.5L	20	18		
ABO620-4T5.5G/7.5LB	5.5G	20	18	550	≥67
	7.5L	32	25		
ABO620-4T7.5G/11LB	7.5G	32	25	550	≥67
	11L	40	32		
ABO620-4T11G/15LB	11G	40	32	800	≥40
	15L	50	40		
ABO620-4T15G/18.5LB	15G	50	40	1100	≥23
	18.5L	63	50		
ABO620-4T18.5G/22LB	18.5G	63	50	1300	≥20
	22L	63	50		
ABO620-4T22G/30LB	22G	63	50	1500	≥20
	30L	100	65		
ABO620-4T30G/37L(B/D/H)	30G	100	65	2500	≥12
	37L	100	80		
ABO620-4T37G/45L(B/D/H)	37G	100	80	2800	≥12
	45L	125	95		
ABO620-4T45G/55LD(H)	45G	125	95	3000	≥10
	55L	160	150		
ABO620-4T55G/75LD(H)	55G	160	150	3600	≥10
	75L	225	185		
ABO620-4T55G/75L(B)	55G	160	150	3600	≥8
	75L	225	185		
ABO620-4T75G/90L(B)	75G	225	185	5000	≥5
	90L	250	225		

ABO620-4T90G/110L	90G	250	225	Brake chopper should be externally mounted when needed
	110L	315	265	
ABO620-4T110G/132L	110G	315	265	
	132L	350	330	
ABO620-4T132G/160L	132G	350	330	
	160L	400	330	
ABO620-4T160G/185L	160G	400	330	
	185L	500	400	
ABO620-4T185G/200L	185G	500	400	
	200L	500	400	
ABO620-4T200G/220L	200G	500	400	
	220L	630	500	
ABO620-4T220G/250L	220G	630	500	
	250L	630	500	
ABO620-4T250G/280L	250G	630	500	
	280L	800	630	
ABO620-4T280G/315L	280G	800	630	
	315L	800	630	
ABO620-4T315G/355L	315G	800	630	
	355L	1000	800	
ABO620-4T355G/400L	355G	1000	800	
	400L	1250	800	
ABO620-4T400G/450L	400G	1250	800	
	450L	1250	1000	
ABO620-4T450G/500L	450G	1250	1000	
	500L	1600	1000	
ABO620-4T500G		1600	1000	
ABO620-4T560G		1600	1250	
ABO620-4T630G		2000	1600	

* When brake chopper is built in, the power and resistance value of brake resistor should meet the requirement as stated in the table. When brake chopper is mounted externally, the power and resistance value of brake resistor should be in accordance with brake chopper.

** On the premise of fulfilling brake requirement, brake resistance value might be bigger than the minimum value as stated in the table. Failure to comply may result in damage to the drive. Brake resistors are not built in and need to be sourced additionally.

3.5 Terminal Configuration

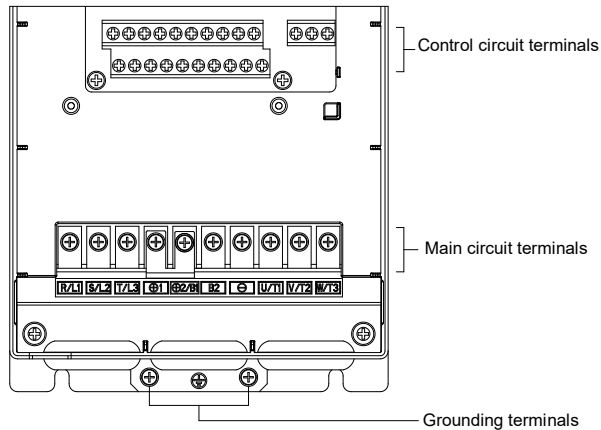

Fig. 3-13 Terminal configuration

3.6 Main Circuit Terminals and Wiring

WARNING

- Only qualified personnel familiar with AC motor drives are allowed to implement wiring. Failure to comply may result in equipment damage and/or personnel injury even death.
- Wiring should be in strict accordance with this manual, otherwise hazard of electric shock or equipment damage exists.
- Make sure input power supply has been completely disconnected before wiring operation. Failure to comply will result in personnel injury even death.
- All wiring operations and lines should comply with EMC and national and local industrial safety regulations and/or electrical codes. The conductor diameter should be in accordance with recommendations of this manual. Otherwise, hazard of equipment damage, fire, and/or personnel injury exists.
- Since leakage current of the drive may exceed 3.5mA, for safety's sake, the drive and the motor must be grounded so as to avoid hazard of electric shock.
- Be sure to perform wiring in strict accordance with the drive terminal marks. Never connect three-phase power supply to output terminals U/T1, V/T2 and W/T3. Failure to comply will result in equipment damage.
- Only mount braking resistors at terminals ⊕ (⊕1) and B2 (BR) when needed. Failure to comply will result in equipment damage.
- Wiring screws and bolts for main circuit terminals must be screwed tightly. Failure to comply may result in faults and/or equipment damage.

 **ATTENTION**

- Signal wires should be away from main power lines to the best of possibility. In the event that this cannot be ensured, vertical cross arrangement should be adopted, reducing EMI interference to the signal wires as much as possible.
- In case the motor cable exceeds 100m, an appropriate output reactor should be mounted.

3.6.1 Main Circuit Terminals of ABO620-4T0.75G/1.5LB~ABO620-4T3.7G/5.5LB

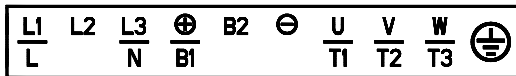

Terminal marks	Designation and function of terminals
L1/L、 L2、 L3/N	Single / Three-phase AC input terminals (Connect L1/L, L3/N when use single phase input)
⊕/B1、 B2	Braking resistor connection terminals when brake unit is inbuilt
⊕/B1、 ⊖	DC input terminals
U/T1、 V/T2、 W/T3	Three-phase AC output terminals
⊕	Ground terminal PE

3.6.2 Main Circuit Terminals of ABO620-4T5.5G/7.5LB~ABO620-4T22G/30LB

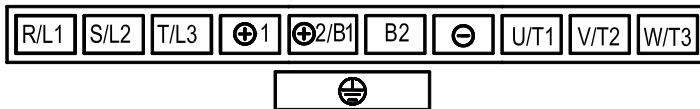

Terminal marks	Designation and function of terminals
R/L1, S/L2, T/L3	Three-phase AC input terminals
⊕1, B2	Braking resistor connection terminals when brake unit is inbuilt*
⊕1, ⊖	DC power supply input terminals**
U/T1, V/T2, W/T3	Three-phase AC output terminals
⊕	Ground terminal PE

* For ABO620-4T5.5G/7.5LB terminal ⊕1 is deleted, brake resistor connection terminals are ⊕2 and B2

**For ABO620-4T5.5G/7.5LB DC power supply input terminals are ⊕2 and ⊖ .

3.6.3 Main Circuit Terminals of ABO620-4T30G/37L(B/D/H)~

ABO620-4T37G/45L(B/D/H)



Terminal marks	Designation and function of terminals
R/L1, S/L2, T/L3	Three-phase AC input terminals
BR, ⊕	Braking resistor connection terminals when brake unit is inbuilt*
⊕, ⊖	DC power supply input terminals
U/T1, V/T2, W/T3	Three-phase AC output terminals
⊕	Ground terminal PE

*For 30kW~37kW drives without "B" or "H" in the model number, there is no built-in brake unit as factory default,

brake resistor connected between BR and ⊕ terminals is invalid.

3.6.4 Main Circuit Terminals of ABO620-4T45G/55LD(H)~ABO620-4T55G/75LD(H)

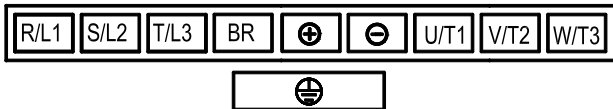

Terminal marks	Designation and function of terminals
R/L1, S/L2, T/L3	Three-phase AC input terminals
BR, ⊕	Braking resistor connection terminals when brake unit is inbuilt*
⊕, ⊖	DC power supply input terminals
U/T1, V/T2, W/T3	Three-phase AC output terminals
⊕	Ground terminal PE

*For 45kW~55kW drives without "H" in the model number, there is no built-in brake unit as factory default, brake

resistor connected between BR and ⊕ terminals is invalid.

3.6.5 Main Circuit Terminals of ABO620-4T75G/90L(B)

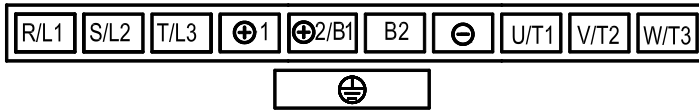

Terminal marks	Designation and function of terminals
R/L1、S/L2、T/L3	Three-phase AC input terminals
⊕1、⊕2/B1	DC reactor connection terminals. Connected with a jumper as factory default *
⊕2/B1、B2	Braking resistor connection terminals when brake unit is inbuilt*
⊕2/B1、⊖	DC input terminals of external- mounted brake unit
⊕1、⊖	DC power supply input terminals
U/T1、V/T2、W/T3	Three-phase AC output terminals
Ⓧ	Ground terminal PE

* For 75kW drives without "B" in the model number, there is no built-in brake unit as factory default, brake resistor connected between B1 and B2 terminals is invalid.

3.6.6 Main Circuit Terminals of ABO620-4T90G/110L ~ ABO620-4T500G

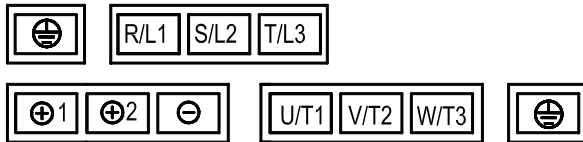

Terminal marks	Designation and function of terminal
R/L1、S/L2、T/L3	Three-phase AC input terminals
⊕1、⊕2	DC reactor connection terminals *
⊕2、⊖	DC input terminals of external- mounted brake unit
⊕1、⊖	DC power supply input terminals
U/T1、V/T2、W/T3	Three-phase AC output terminals
Ⓧ	Ground terminal PE

*ABO620-4T90G/110L~ABO620-4T500G have external-mounted DC reactor in shipment as default. Be sure to connect the DC reactor between terminals ⊕1 and ⊕2, or there will be no display when applying power on the drives.

3.6.7 Main Circuit Terminals of ABO620-4T560G ~ ABO620-4T630G

Terminals are copper bar for ABO620-4T560G ~ ABO620-4T630G as

following:



Terminal marks	Designation and function of terminals
R/L1, S/L2, T/L3	Three-phase AC input terminals
U/T1, V/T2, W/T3	Three-phase AC output terminals
	Ground terminal PE

3.6.8 Terminal Screw and Wiring Requirement

Table 3-4 Terminal screw and wiring requirement

■ ABO620-4T□□□G/□□□□□ Three-phase 400V input

Drive model		Power terminal			Ground terminal		
		Cable (mm ²)	Screw	Torque (kgf.cm)	Cable (mm ²)	Screw	Torque (kgf.cm)
ABO620-4T0.75G/1.5LB	0.75G	2.5	M3.5	10±0.5	2.5	M3.5	10±0.5
	1.5L	2.5			2.5		
ABO620-4T1.5G/2.2LB	1.5G	2.5	M3.5	10±0.5	2.5	M3.5	10±0.5
	2.2L	2.5			2.5		
ABO620-4T2.2G/3.7LB	2.2G	2.5	M3.5	10±0.5	2.5	M3.5	10±0.5
	3.7L	2.5			2.5		
ABO620-4T3.7G/5.5LB	3.7G	2.5	M3.5	10±0.5	2.5	M3.5	10±0.5
	5.5L	2.5			2.5		
ABO620-4T5.5G/7.5LB	5.5G	2.5	M4	14±0.5	2.5	M4	14±0.5
	7.5L	4			4		
ABO620-4T7.5G/11LB	7.5G	4	M4	14±0.5	4	M4	14±0.5
	11L	4			4		
ABO620-4T11G/15LB	11G	4	M4	14±0.5	4	M4	14±0.5
	15L	6			6		
ABO620-4T15G/18.5LB	15G	6	M5	28±0.5	6	M4	14±0.5
	18.5L	10			10		
ABO620-4T18.5G/22LB	18.5G	10	M5	28±0.5	10	M4	14±0.5
	22L	10			10		
ABO620-4T22G/30LB	22G	10	M5	28±0.5	10	M4	14±0.5
	30L	16			16		
ABO620-4T30G/37L(B/D/H)	30G	16	M6	48±0.5	16	M6	48±0.5
	37L	25			16		
ABO620-4T37G/45L(B/D/H)	37G	25	M6	48±0.5	16	M6	48±0.5
	45L	35			16		
ABO620-4T45G/55LD(H)	45G	35	M8	120±0.5	16	M8	120±0.5
	55L	50			25		
ABO620-4T55G/75LD(H)	55G	50	M8	120±0.5	25	M8	120±0.5
	75L	70			35		
ABO620-4T75G/90L(B)	75G	70	M10	250±0.5	35	M8	120±0.5
	90L	95			50		

Drive model		Power terminal			Ground terminal		
		Cable (mm ²)	Screw	Torque (kgf.cm)	Cable (mm ²)	Screw	Torque (kgf.cm)
ABO620-4T90G/110L	90G	95	M12	440±0.5	50	M12	440±0.5
	110L	120			70		
ABO620-4T110G/132L	110G	120	M12	440±0.5	70	M12	440±0.5
	132L	120			70		
ABO620-4T132G/160L	132G	120	M12	440±0.5	70	M12	440±0.5
	160L	150			95		
ABO620-4T160G/185L	160G	150	M12	440±0.5	95	M12	440±0.5
	185L	185			95		
ABO620-4T185G/200L	185G	185	M12	440±0.5	95	M12	440±0.5
	200L	185			95		
ABO620-4T200G/220L	200G	185	M12	440±0.5	95	M12	440±0.5
	220L	240			120		
ABO620-4T220G/250L	220G	240	M12	440±0.5	120	M12	440±0.5
	250L	120x2			120		
ABO620-4T250G/280L	250G	120x2	M16	690±0.5	120	M16	690±0.5
	280L	120x2			120		
ABO620-4T280G/315L	280G	120x2	M16	690±0.5	120	M16	690±0.5
	315L	150x2			150		
ABO620-4T315G/355L	315G	150x2	M16	690±0.5	150	M16	690±0.5
	355L	185x2			95x2		
ABO620-4T355G/400L	355G	185x2	M16	690±0.5	95x2	M16	690±0.5
	400L	240x2			120x2		
ABO620-4T400G/450L	400G	240x2	M16	690±0.5	120x2	M16	690±0.5
	450L	240x2			120x2		
ABO620-4T450G/500L	450G	240x2	M16	690±0.5	120x2	M16	690±0.5
	500L	240x2			120x2		
ABO620-4T500G		240x2	M16	690±0.5	120x2	M16	690±0.5
ABO620-4T560G		300x2	M16	690±0.5	150x2	M16	690±0.5
ABO620-4T630G		300x2	M16	690±0.5	150x2	M16	690±0.5

3.7 Control Terminal Wiring



WARNING

- Only qualified personnel familiar with AC motor drives are allowed to implement wiring. Failure to comply may result in equipment damage and/or personnel injury even death.
- Wiring should be in strict accordance with this manual, otherwise hazard of electric shock or equipment damage exists.
- Make sure input power supply has been completely disconnected before wiring operation. Failure to comply will result in personnel injury even death.
- All wiring operations and lines should comply with EMC and national and local industrial safety regulations and/or electrical codes. The conductor diameter should be in accordance with recommendations of this manual. Otherwise, hazard of equipment damage, fire, and/or personnel injury exists.
- Screws or bolts for terminal wiring must be screwed tightly.
- AC 220V signal is prohibited from connecting to terminals other than control terminals RA, RB and RC.



ATTENTION

- Signal wires should be away from main power lines to the best of possibility. If this cannot be ensured, vertical cross arrangement should be adopted, reducing EMI interference to the signal wires as much as possible.
- The encoder must be provided with shielded cables whose shielded layer must be properly grounded.

3.7.1 Control Board Diagram

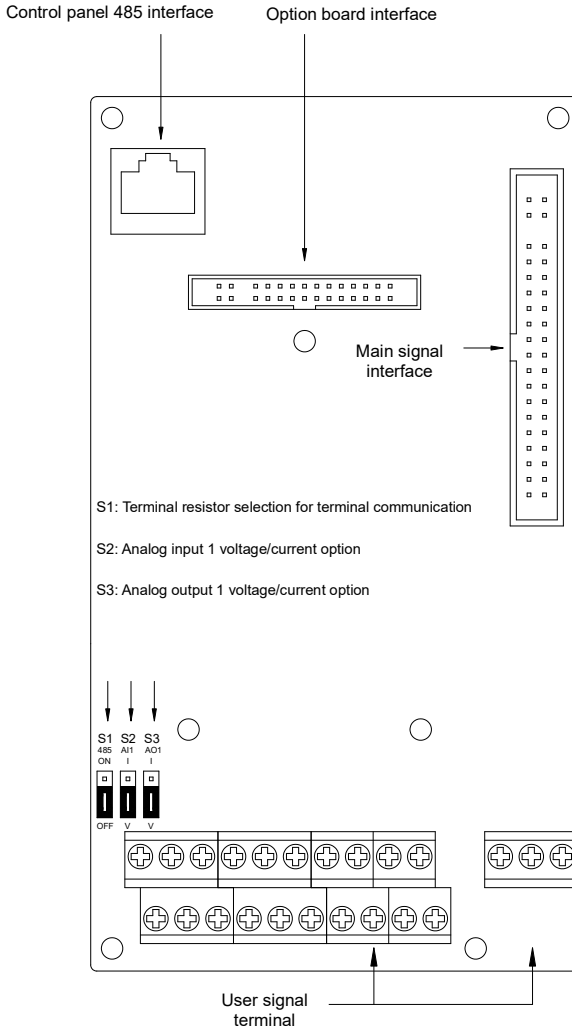

Fig. 3-14 Control board diagram

3.7.2 Wiring Diagram

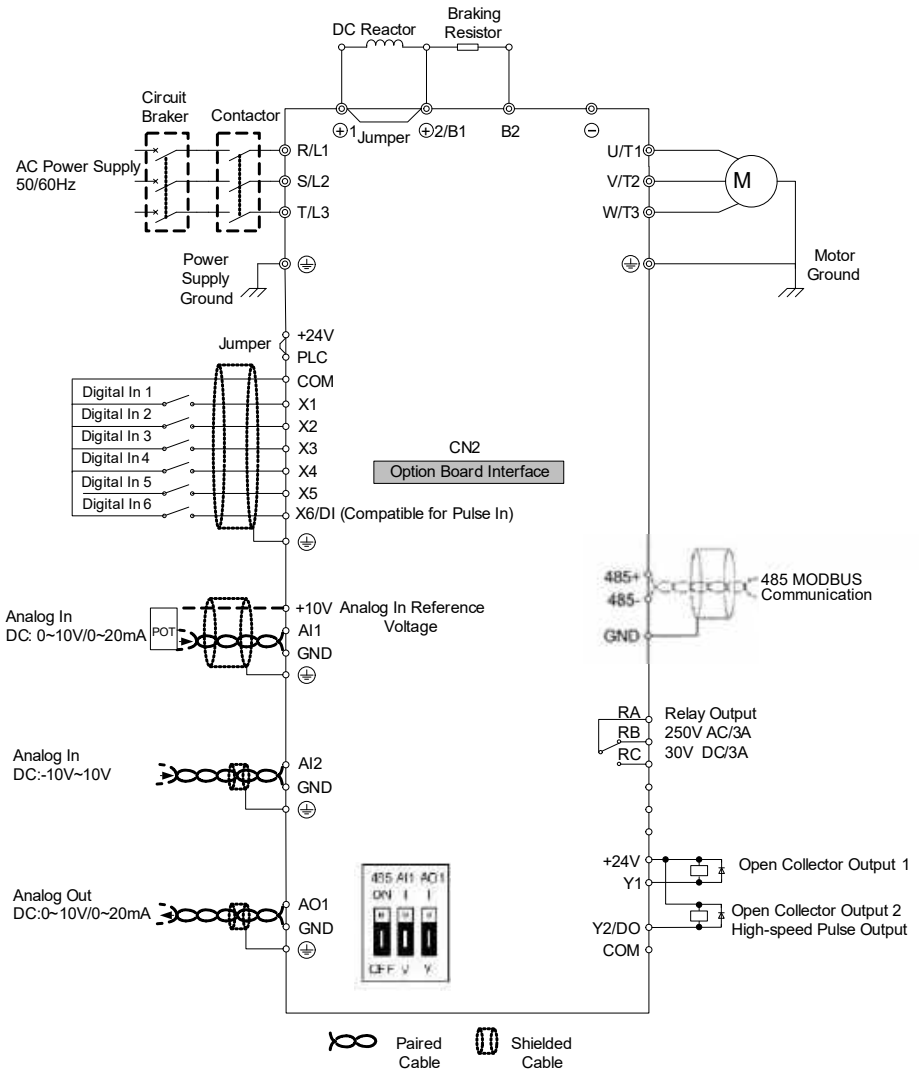

Fig. 3-15 Wiring diagram

3.8 Control Terminal Specification

Table 3-5 Control terminal specification

Category	Terminal	Terminal designation	Specification
Analog input	+10V	Analog input reference voltage	10.3V ±3%
			Maximum output current 25mA The resistance of external potentiometer should be larger than 400Ω
	GND	Analog ground	Isolated from COM interiorly
	AI1	Analog input 1	0~20mA: input impedance - 500Ω, maximum input current - 25mA
			0~10V: input impedance - 22kΩ, maximum input voltage - 12.5V Switch S2 on control board for jumping from 0~20mA and 0~10V, factory default: 0~10V
	AI2	Analog input 2	-10V~10V: input impedance - 25kΩ Range: -12.5V~+ 12.5V
Analog output	AO1	Analog output 1	0~20mA: impedance - 200Ω~500Ω
			0~10V: impedance ≥ 10k Switch S3 on control board for jumping between 0~20mA and 0~10V, factory default: 0~10V
	GND	Analog ground	Isolated from COM interiorly
Digital input	+24V	+24V	24V±10%, Isolated from GND interiorly
			Maximum load - 200mA
	PLC	Digital input Common terminal	Used for switching between high and low levels, short-circuited with +24V when delivery, i.e. low value of digital input valid
			External power input
	COM	+24V ground	Isolated from GND interiorly
	X1~X5	Digital input Terminals 1~5	Input: 24VDC, 5mA
Range of frequency: 0~200Hz Range of voltage: 10V~30V			
X6/DI	Digital input/pulse input	Digital input: same as X1~X5	
		Pulse input: 0.1Hz~50kHz; range of voltage: 10-30V	
Digital output	Y1	Open collector output	Range of voltage: 0~24V
			Range of current: 0~50mA

Category	Terminal	Terminal designation	Specification
Digital output	Y2/DO	Open collector out / Pulse out	Open collector output: same as Y1 Pulse output: 0~50kHz;
Relay output	RA/RB/RC	Control board relay output	RA-RB: NC; RA-RC: NO Contact capacity: 250VAC/3A, 30VDC/3A
Terminal 485 Interface	485+	485 differential signal +	Rate: 4800/9600/19200/38400/57600/115200bps Maximum distance - 500m (standard network cable used)
	485-	485 differential signal -	
	GND	485 communication shield grounding	Isolated from COM interiorly
Control panel 485 interface	CN4 (CN12)	Control panel 485 interface	Maximum communication distance is 15m when connected to Control panel Use standard network cable

3.9 Control Terminal Usage

3.9.1 Lay-out of Control Terminals

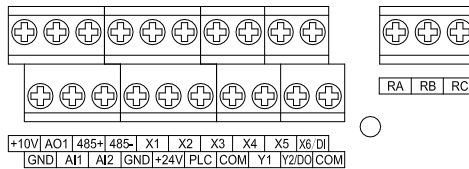

Fig. 3-16 Lay-out of control terminals

3.9.2 Control Terminal Screw and Wiring Requirement

Table 3-6 Terminal screw and wiring specification

Cable type	Cable requirement (mm ²)	Screw	Torque (kgf.cm)
Shielded cable	1.0	M3	5±0.5

3.9.3 Instructions of Analog Input/Output Terminals

Being particularly vulnerable to noise, analog input & output signal cables should be as short as possible, shielded, and their shielded layers should be properly grounded close to the side of drive. The cables should not exceed 20m.

Control cables shall be kept no less than 20cm away from main circuit and strong current lines (e.g. power lines, motor lines, relay lines and contactor lines) and should not be arranged in parallel with strong current lines. In case it is inevitable to intersect strong current line, vertical wiring is recommended to avoid drive faults as a result of noise.

Where analog input & output signals are severely interfered, the side of analog signal source should be provided with filter capacitor or ferrite core.

3.9.4 Instructions of Digital Input/Output Terminals

Digital input & output signal cables should be as short as possible, shielded, and their shielded layers should be properly grounded close to the side of drive. The cables should not exceed 20m. When active drive is selected, take necessary filtering measures against power crosstalk, for which dry contact control is recommended.

Control cables shall be kept no less than 20cm away from main circuit and strong current lines (e.g. power lines, motor lines, relay lines and contactor lines) and should not be arranged in parallel with strong current lines. In case it is inevitable to intersect strong current line, vertical wiring is recommended to avoid drive faults as a result of noise. Operating instructions for switching value input terminal

- Instructions of digital input terminal
- ◆ Dry contact

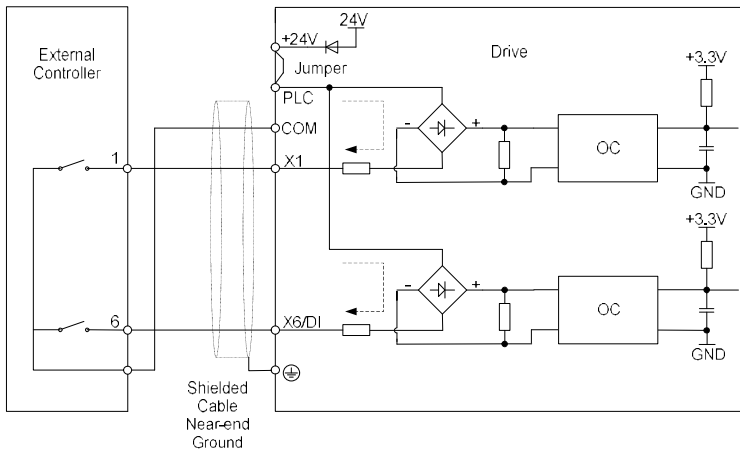

Fig. 3-17 Internal power supply dry contact

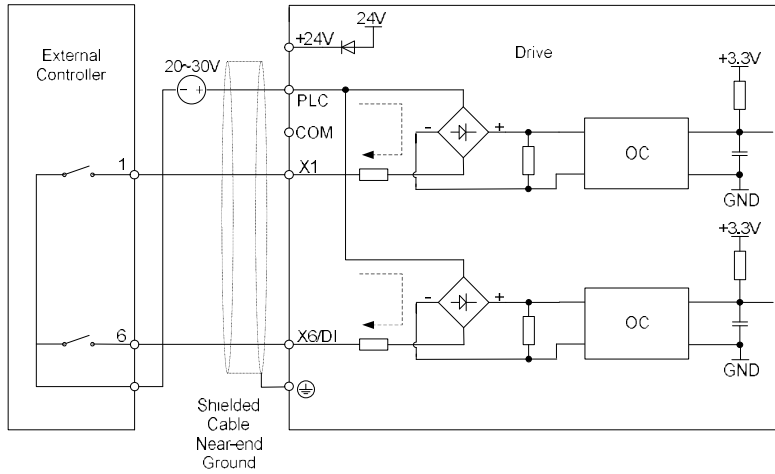

Fig. 3-18 External power supply dry contact

ATTENTION:

- When external power supply is used, the jumper between +24V and PLC must be removed. Otherwise, it may result in equipment damage.
- The voltage range of external power supply should be DC20~30V. Otherwise, normal operation could not be assured and/or result in equipment damage.

◆ Open collector NPN connection

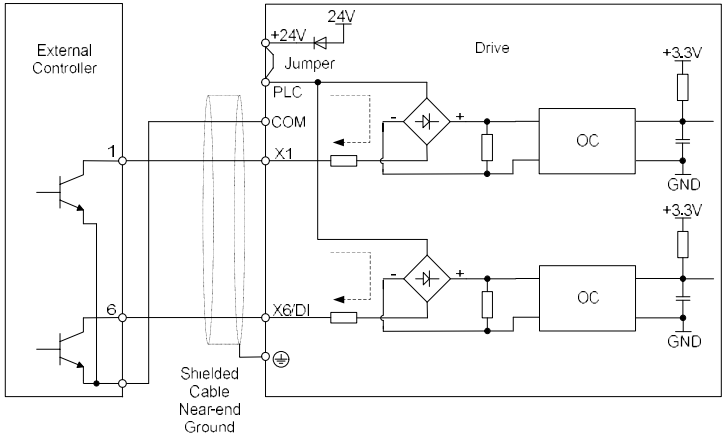

Fig. 3-19 Internal power supply open collector NPN connection

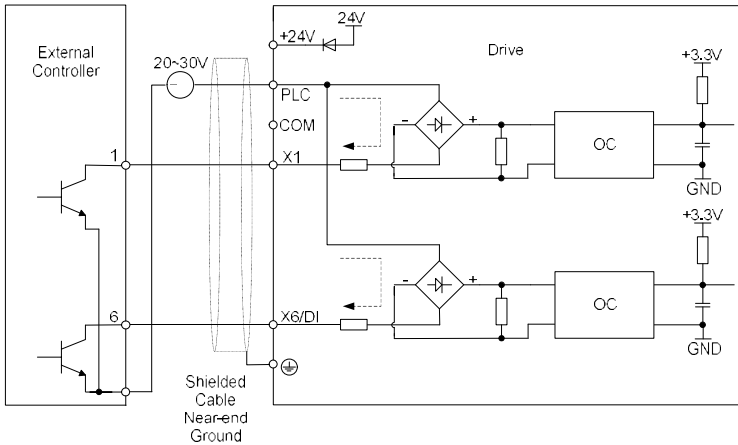

Fig. 3-20 External power supply open collector NPN connection

📖 **ATTENTION:**

When external power supply is used, the jumper between +24V and PLC must be removed. The voltage range of external power supply should be DC20~30V, otherwise normal operation could not be assured and/or hazard of equipment damage exists.

◆ **Open collector PNP connection**

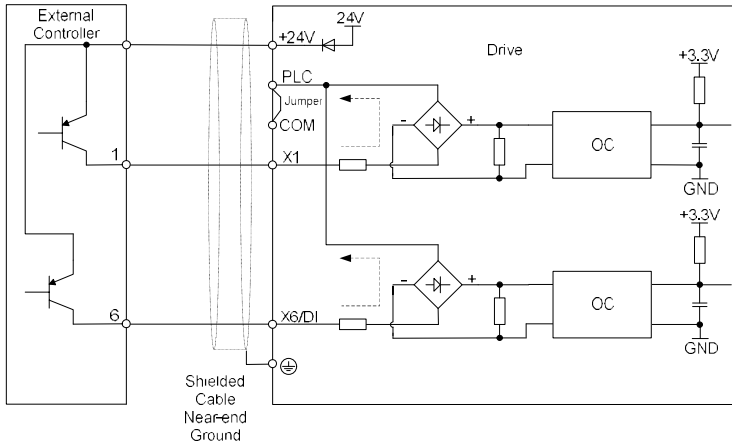

Fig. 3-21 Internal power supply open collector PNP connection

ATTENTION:

When PNP connection is adopted, it is necessary to remove the jumper between +24V and PLC, and connect the jumper to PLC and COM.

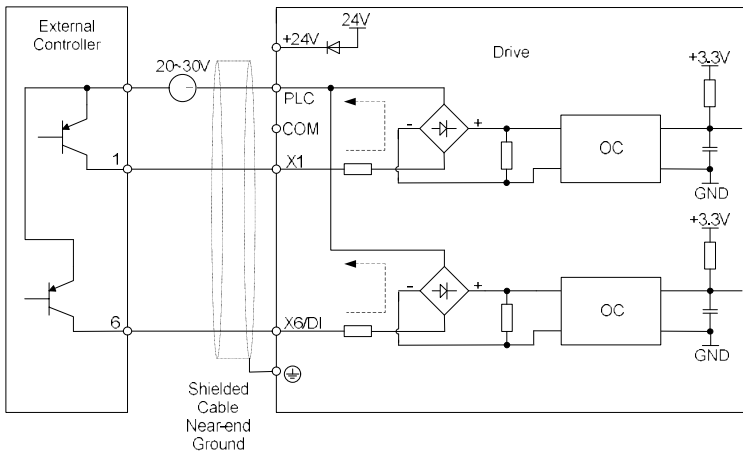

Fig. 3-22 External power supply open collector PNP connection

ATTENTION:

When external power supply is used, the jumper between +24V and PLC must be removed. The voltage range of external power supply should be DC20~30V. Otherwise, normal operation could not be assured and/or hazard of equipment damage exists.

- Instructions of digital output terminal
- ◆ Instructions of Y1 and Y2/DO output terminals

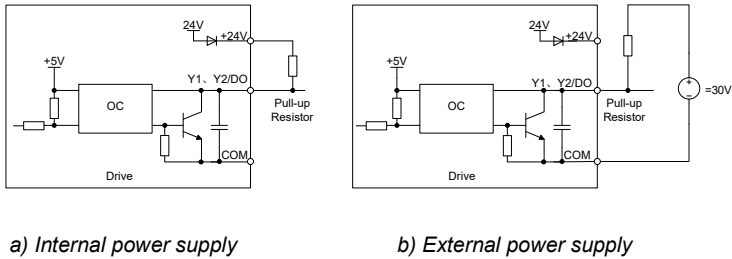

Fig. 3-23 Wiring when Y1 and Y2/DO output with pull-up resistor

ATTENTION:

When set to be pulse output, Y2/DO terminal shall output 0~50kHz pulse signal.

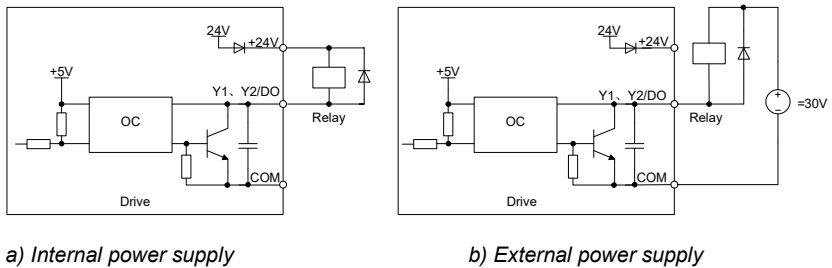

Fig. 3-24 Wiring when Y1 and Y2/DO drive relay

ATTENTION:

When relay coil voltage is lower than 24V, a resistor as voltage divider should be mounted between relay and output terminal, based on coil impedance.

◆ Wiring instruction of relay output terminal

Control board of ABO620 series drive is provided with a group of programmable relay dry contact outputs. RA/RB/RC are relay contacts. RA and RB are normally closed, while RA and RC are normally open. See parameter C1-02 for details.

ATTENTION:

In case inductive load (e.g. electromagnetic relay or contactor) is to be driven, a surge voltage absorbing circuit such as RC absorbing circuit (note that its leakage current shall be less than holding current of controlled contactor or relay), piezoresistor or fly-wheel diode etc. shall be mounted (be sure to pay close attention to polarity in case of DC electromagnetic circuit). Absorbing devices should be mounted close to the ends of relay or contactor.

3.9.5 Instructions of RS485 Communication Terminals

It is recommended to apply chain connection as Fig. 3-25 (“one-to-many” star connection cannot be applied) between RS485 communication nodes of the drive and host computer etc. Try to lay 485 communication cables away from power cables and machine cabinets.

There should be at least three cables as RS485 communication bus: two paired cables which can effectively resist outside noise interference is used to connect 485 signal terminal; the third cable (also called equipotential cable) is used to connect power supply reference of communication circuit of each 485 node, thus to prevent communication circuit of each node from being damaged due to big difference of reference potential. To ensure communication bus away from noise current loop, equipotential cable cannot be connected to ground or machine cabinet.

For normal industrial application, generally paired shielded cables are selected as 485 communication bus; the shielded layer can work as equipotential cable, and shall be kept as intact as possible during cable layout. Multi-cored paired cables (e.g. Ethernet cable) can also be selected to connect each 485 node; select one pair of paired cables to connect 485 signal terminals, and wrest other cables together as equipotential connection. For handmade paired cables, the conducting section area of wire shall be $\geq 0.2\text{mm}^2$, twisted space shall be $\leq 15\text{mm}$, conducting section area of equipotential wire shall be $\geq 1\text{mm}^2$, and be closely laid to paired cable.

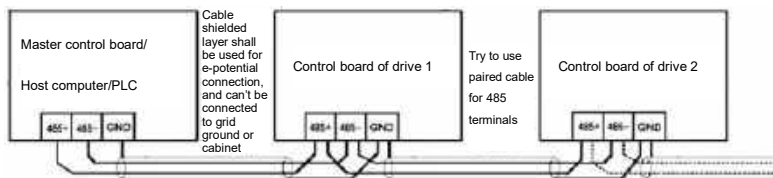

Fig. 3-25 Wiring diagram of RS485 communication terminal

There may be no lead-out terminals of communication power supply reference for some 485 nodes, then try to find reference ground of 485 communication circuit on board related to the node, lead out wire for equipotential connection (simply connecting them to ground or other irrelevant terminals is not allowed). If reference ground of 485 communication circuit cannot be found, then hang equipotential wire of the node in air, meanwhile connect ground of the 485 node and ground of neighbor 485 node with other grounding wire.

Connect a terminal resistor on end node of 485 communication bus according to requirement. On one aspect, if high-frequency characteristic impedance determined by paired cable structure is close to the terminal resistor value, communication signal quality will be promoted by connecting a terminal resistor; on another aspect, communication loop load will be increased, and voltage amplitude of signal will be decreased if a terminal resistor is connected.

3.10 Instruction of Signal Switches

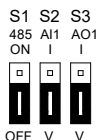

Fig. 3-26 Jumper diagram of signal switching

Designation	Function	Default setting
S1	Selection of 485 termination resistor; ON :100Ω termination resistor provided; OFF: no termination resistor	OFF
S2	Type Selection of AI1 analog signal: I: current input (0~20mA); V: voltage input (0~10V)	V: 0~10V
S3	Type Selection of AO1 analog signal: I: current output (0~20mA); V: voltage output (0~10V)	V: 0~10V

3.11 EMI Solutions

Due to its working principle, the drive will inevitably produce certain noise that may influence and disturb other equipment. Moreover, since the internal weak electric signal of drive is also susceptible to the interference of drive itself and other equipment, EMI problems shall be inevitable. In order to reduce or avoid the interference of drive to external environment and protect drive against interference from external environment, this section makes a brief description of noise abatement, ground handling, leakage current suppression and the application of power line filters.

3.11.1 Noise Abatement

When peripheral equipment and drive share the power supply of one system, noise from the drive may be transmitted to other equipment in this system via power lines and result in misoperation and/or faults. In such a case, the following measures could be taken:

- Mount input noise filter at input terminal of the drive;
- Mount power supply filter at power input terminal of affected equipment;
- Use isolation transformer to isolate the noise transmission path between other equipment and the drive.

As the wiring of peripheral equipment and the drive constitutes a circuit, the unavoidable earthing leakage current of the drive will cause equipment misoperation and/or faults. Disconnect the grounding connection of equipment may avoid this misoperation and/or faults

Sensitive equipment and signal lines shall be mounted as far away from the drive as possible. Signal lines should be provided with shielded layer and reliably grounded. Alternatively, signal cable could be put into metallic conduits between which the distance shall be no less than 20cm, and shall be kept as far away from the drive, its peripheral devices, and cables as possible. Never make signal lines in parallel with power lines or bundle them up.

Signal lines must orthogonally cross power lines if this cross is inevitable. Motor cables shall be placed in thick protective screen like more than 2mm-thick pipelines or buried in cement groove, also, power lines can be put into metallic conduit and grounded well with shielded cables.

Use 4-core motor cables of which one is grounded at close side of the drive and the other side is connected to motor enclosure.

Input and output terminals of the drive are respectively equipped with radio noise filter and linear noise filter. For example, ferrite common mode choke can restrain radiation noise of power lines.

3.11.2 Grounding

Recommended ground electrode is shown in the figure below:

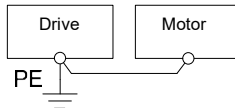

Fig. 3-27 Grounding

Use to the fullest extent the maximum standard size of grounding cables to reduce the impedance of grounding system.

Grounding wires should be as short as possible. Grounding point shall be as close to the drive as possible.

One wire of 4-core motor cables shall be grounded at the drive side and connected to grounding terminal of motor at the other side. Better effect will be achieved if motor and drive are provided with dedicated ground electrodes.

When grounding terminals of various parts of system are linked together, leakage current turns into a noise source that may influence other equipment in the system, thus, grounding terminals of the drive and other vulnerable equipment should be separated. Grounding cable shall be kept away from inlet & output of noise-sensitive equipment.

3.11.3 Leakage Current Suppression

Leakage current passes through the line-to-line and ground distributed capacitors at input & output sides of drive, and its size is associated with the capacitance of distributed capacitor and the switching frequency. Leakage current is classified into ground leakage current and line-to-line leakage current.

Ground leakage current not only circulates inside drive system, but may also influence other equipment via ground loop. Such a leakage current may result in malfunction of RCD and other equipment. The higher the switching frequency of drive is, the bigger the ground leakage current will be. The longer the motor cables and the bigger the parasitic capacitance are, the bigger the ground leakage current will be. Therefore, the most immediate and effective method for suppression of ground leakage current is to reduce the switching frequency and minimize the length of motor cables.

The higher harmonics of line-to-line leakage current that passes through between cables at output side of drive will accelerate the aging of cables and may bring about malfunction of other equipment. The higher the switching frequency of drive is, the bigger the line-to-line leakage current will be. The longer the motor cables and the bigger the parasitic capacitance are, the bigger the line-to-line leakage current will be. Therefore, the most immediate and effective method for suppression of ground leakage current is to reduce the switching frequency and minimize the length of motor cable. Line-to-line leakage current can also be effectively suppressed by mounting additional output reactors.

3.11.4 Use of Power Supply Filter

Since AC drives may generate strong interference and are also sensitive to outside interference, power supply filters are recommended. Pay close attention to the following instructions during the use:

- Enclosure of the filter needs to be reliably grounded;
- Input lines of the filter shall be kept as far away from output lines as possible so as to avoid mutual coupling;
- Filter shall be as close to the drive side as possible;
- Filter and drive must be connected to the same common ground.

Chapter 4 Operation and Run Instructions

4.1 Operation of Control Panel

As a human-machine interface, control panel is the main part for the drive to receive command and display parameters.









Fig. 4-1 Control panel

4.1.1 Key Functions on Control Panel

On the control panel there are 8 keys whose functions are as shown in Table 4-1.

Table 4-1 Key functions on control panel

Symbol	Key name	Meaning
	Enter key	1) Parameter edition enter 2) Confirmation of parameter settings 3) Confirmation of MF key function
	Escape key	1) Return function 2) Invalid parameter edit value
	Increase key	1) Increase of selected bit of parameter value 2) Increase of selected bit of parameter value 3) Increase of set frequency
	Decrease key	1) Decrease of selected bit of parameter 2) Decrease of selected bit of parameter value 3) Decrease of set frequency
	Shift key	1) Selection of parameter bit 2) Selection of parameter value bit 3) Selection of stop/run status display parameter value 4) Fault status switches to parameter value display status
	Run key	Run





Symbol	Key name	Meaning
	Stop/reset key	1) Stop 2) Fault reset
	Multi-function key	See Table 4-2 " MF key function definition"

Table 4-2 MF key function definition

L0-00 set value	Function of MF key	Meaning
0	Disabled	MF key disabled
1	Forward JOG	Forward JOG function
2	Reverse JOG	Reverse JOG function
3	Forward/Reverse switch	Running direction forward and reverse switching
4	Emergency STOP 1	Press  to STOP, with ramp-down time b2-09
5	Emergency STOP 2	Coast to stop, the drive cuts off output
6	Run command setting mode switch	Control panel control -> Terminal control -> Communication control -> Control panel control, press  to confirm within 5 seconds

4.1.2 Control Panel Indicators

Control panel is furnished with 7 indicators whose descriptions are as below

Table 4-3 Description of indicators

Indicator	Designation	Meaning
Hz	Frequency indicator	ON: currently displayed parameter value is running frequency or the current parameter unit is frequency Flash: currently displayed parameter value is set frequency
A	Current indicator	ON: currently displayed parameter value is current
V	Voltage indicator	ON: currently displayed parameter value is voltage
Hz+A	Running speed indicator	ON: currently displayed parameter value is running speed Flash: currently displayed parameter value is setting speed
A+V	Percentage indicator	ON: currently displayed parameter value is a percentage value
All OFF	No unit	No unit
MON	Run command setting mode indicator	ON: Control panel OFF: Terminal Flash: Communication
RUN	Run status indicator	ON: Run OFF: Stop Flash: Stopping
FWD	Forward indicator	ON: If the drive in stop status, forward command enabled. If the drive in run status, the drive is running forward Flash: Forward is being transferred to reverse
REV	Reverse indicator	ON: If the drive in stop status, reverse command enabled. If the drive in run status, the drive is running reversely. Flash: Reverse is being transferred to forward

4.1.3 Control Panel Display Status

Control panel indicates eight types of status, STOP parameters display, Run parameters display, Fault display, parameter number edition, parameter setting, Password authentication, Direct frequency modification and Prompt message. The operation relating to these statuses and the switching among these statuses is described as follows.

4.1.3.1 Display of STOP Parameters







The drive normally gets into STOP parameters display once run has been stopped. By default, set frequency is displayed in such a status, and other parameters can be displayed through setting of L1-02 parameters and the  key. For example, when users need to check set frequency as well as the values of bus voltage and AI1 value in stop status, set L1-02=0013 (refer to setting method of parameters) and press the  key to display the value of bus voltage and then press  again to display the value of AI1.



Fig. 4-2 Stop parameter display status (Displaying setting frequency – 50.00Hz)

Run status will be enabled immediately upon receipt of run command in stop status. Press  to get into parameter edit status (get into password authentication status if parameter under password protection). Directly get into frequency modification status when receive UP/DOWN command from terminal, or  and  pressing on control panel. Switch to fault display status once a fault occurs or an alarm is given.

4.1.3.2 Run Parameter Display Status





In case there is no fault, the drive will get into run parameters display status upon receipt of run command. Default display is run frequency, and other parameters can be displayed through setting of L1-00 and L1-01 and press  to shift. For example, in run status, when users need to check bus voltage, motor speed, and input terminals status, please set L1-00= 0084 and L1-01= 0004, and press  to shift to the display of bus voltage, then press  again to display motor speed, and then press  to display input terminals state value.



Fig. 4-3 Run parameter display status (Displaying run frequency – 50.00Hz)

Stop status will be enabled immediately upon receipt of stop command in such a status. Press **ENT** to get into parameter edit status (get into password authentication status if parameter under password protection). Directly get into frequency modification status when receiving UP/DOWN command from terminal, or pressing **▲** or **▼**. Switch to fault alarm display status once a fault occurs or an alarm is given.

4.1.3.3 Fault Alarm Display Status

In case a fault occurs or an alarm is given, the drive will get into fault or alarm display status.



Fig. 4-4 Fault or alarm display status (CCL: Contactor act fault)

In such a status, the drive gets into stop status upon receipt of pressing **ENT**, and would get into parameter edit status when receiving pressing **ENT** command again (if parameter is under password protection, the drive would get into password authentication status). Directly get into frequency modification status when receiving UP/DOWN command from terminal, or pressing **▲** or **▼**.

4.1.3.4 Parameter Edit Status

Enter parameter edit status immediately upon pressing **ENT** in STOP status, run parameters display status, and direct frequency modification status. This status could also be entered upon receipt of consecutive twice pressing **ENT** in fault display status. The drive shall quit current status and be previous status upon receipt of pressing **ESC**.



Fig. 4-5 Parameter edit status

4.1.3.5 Parameter Value Setting Status

Enter parameter value setting status upon receipt of pressing **ENT** when in parameter value edit status. When pressing **ENT** or **ESC** command is received in such a state, escape parameter edit status.



Fig. 4-6 Parameter value setting status (b0-02 is set to 49.83Hz)

4.1.3.6 Password Authentication Status

On condition that parameters are under password protection, users would have to go through password authentication when they want to modify function code parameter value. Only A0-00 is visible in such a state.

Under password protection, the password authentication status will be first entered upon the receipt of pressing **ENT** in STOP parameter display status, run parameter display status, or direct frequency modification status (refer to the setting method of parameters). It will enter parameter edit status upon the completion of password authentication.

4.1.3.7 Direct Frequency Modification Status

In the status of STOP, fault or run, the drive will enter frequency modification status when terminal UP/DOWN is enabled, or pressing **▲** or **▼**.



Fig. 4-7 Direct frequency modification status

4.1.3.8 Prompt Message Status

Prompt message status shall be displayed upon the completion of some operations. For instance, the "bASIC" prompt message would be displayed upon the completion of parameter initialization.



Fig. 4-8 Prompt message status

Prompt message characters and their meanings are shown as specified in Table 4-4.

Table 4-4 Prompt characters

Prompt symbol	Meaning	Prompt symbol	Meaning
bASIC	When A0-01 is set to 0	CPyb1	Backup parameter value
dISP1	When A0-01 is set to 1	LoAd	Parameter upload to control panel
USEr	When A0-01 is set to 2	dnLd1	Parameter download from control panel (motor parameter excluded)
ndFLt	When A0-01 is set to 3	dnLd2	Parameter download from control panel (motor parameter included)
LoC-1	Control panel locked 1 (full locked)	P-SEt	Password has been set
LoC-2	Control panel locked 2 (all locked except RUN, STOP/RESET)	P-CLr	Password cleared
LoC-3	Control panel locked 3 (all locked except STOP/RESET)	TUNE	Motor parameter identification in process







































LoC-4	Control panel locked 4 (all locked except shift )	LoU	Drive undervoltage
PrtCt	Control panel protection	CLr-F	Clear fault record
UnLoC	Control panel lock cleared	dEFt1	Restore to factory default parameters (motor parameter excluded)
rECy1	Read the backup parameter value to parameter	dEFt2	Restore to factory default parameters (motor parameter included)

Table 4-5 shows meanings of the characters displayed on control panel.

Table 4-5 Meanings of displayed characters

Displayed character	Character Meaning	Displayed character	Character Meaning	Displayed character	Character Meaning	Displayed character	Character Meaning
	0		A		I		T
	1		b		J		t
	2		C		L		U
	3		c		N		v
	4		d		n		y
	5		E		o		-
	6		F		P		8.
	7		G		q		.
	8		H		r		
	9		h		S		

4.1.4 Setting Method of Parameters

4.1.4.1 Parameter System

ABO620 series drive parameter group: A0~A1, b0~b2, C0~C4, d0~d5, E0~E1, F0~F3, H0~H1, L0~L1, U0~U1. Each parameter group contains a number of parameters. Parameters are identified by the combination "parameter group character + parameter subgroup number + parameter number". For instance, "F3-07" indicates the seventh parameter at subgroup 3, group F.

4.1.4.2 Parameter Display Structure

Parameters and the parameter values are subject to a two-tier structure. Parameters correspond to first-tier display, while parameter values correspond to second-tier display.

First-tier display shown in Fig. 4-9:



Fig. 4-9 First-tier display of parameter

Second-tier display shown in Fig. 4-10:



Fig. 4-10 Second-tier display of parameter ("3" is the value of b0-00)

4.1.4.3 Example of Setting of Parameter

Parameter values are divided into decimal (DEC) and hexadecimal (HEX) values. When a parameter value is expressed by a hexadecimal, all its bits are independent of each other during edition and the range of value would be (0~F). Parameter value is composed of the unit, tens place, hundreds and kilobit. Shift Key **MF** is used to select the bit to be changed, while **▲** and **▼** are used to increase or decrease numerical value.

- Example of parameter password setting
 - ◆ Setting of password (A0-00 is set to 1006)
 - 1) In non-parameter edit status, it displays current parameter A0-00 when pressing **ENT**.
 - 2) Press **ENT** to display parameter value 0000 that belongs to A0-00;
 - 3) Press **▲** for six times to change the rightmost digit "0" to "6";
 - 4) Press **MF** to move the flashing digit to the leftmost bit;
 - 5) Press **▲** once to change "0" in leftmost bit to "1";
 - 6) Press **ENT** to save the value of A0-00, then Control panel will switch to display the next parameter A0-01;
 - 7) Press **▼** to change A0-01 to A0-00;
 - 8) Repeat steps 2) till 6). A0-01 will be displayed after control panel displaying P-SEt;
 - 9) There are three methods for users to bring the password setting above into effect:
 - ① Press **ESC** + **ENT** + **▲** simultaneously (PrtCt displayed),
 - ② won't operate control panel within 5 minutes,
 - ③ restart the drive.

Flow chart of user password setting:

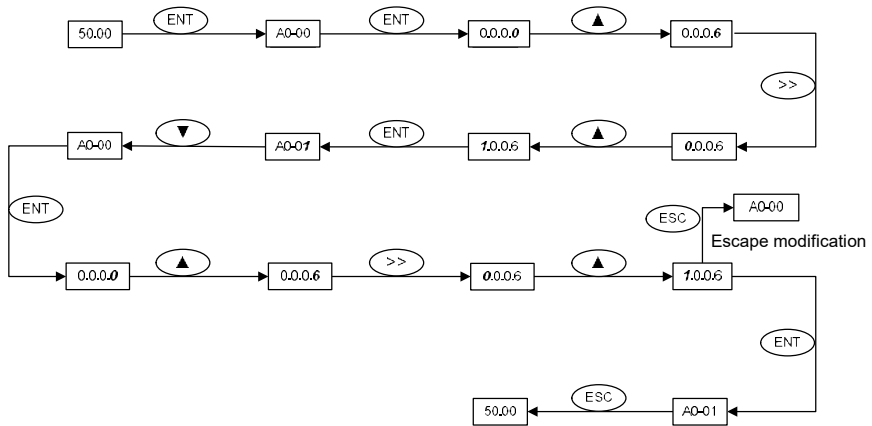

Fig. 4-11 Flow chart of user password setting

ATTENTION:

User's password is successfully set when step 8 finished, but will not take effect until the completion of step 9.

◆ **Password authentication**

In non-parameter edit status, press **ENT** to enter first-tier display A0-00, then press **ENT** to enter second-tier display 0.0.0.0. Control panel will implement the display of other parameters only when correct password entered.

◆ **Clear password**

After successful password authentication, it will access password setting code A0-00. Password can be cleared by writing value 0000 into A0-00 twice.

● **Example of parameter setting**

◆ **Example 1:** modify upper limit frequency from 600Hz to 50Hz (change b0-09 from 600.00 to 50.00)

- 1) In non-parameter edit status, press **ENT** to display current parameter A0-00;
- 2) Press **→** to move flashing digit to modification bit (A flashes);
- 3) Press **▲** once to change "A" to "b";
- 4) Press **→** to move flashing to modification bit (0 in ones place flashing);
- 5) Press **▲** nine times to change "0" to "9";
- 6) Press **ENT** to view the parameter value (600.00) of b0-09;
- 7) Press **→** to move flashing digit to modification digit (6 flashing);
- 8) Press **▼** six times to change "6" to "0";
- 9) Press **→** once to move flashing digit rightwards by one bit;

- 10) Press for five times to change "0" to "5";
- 11) Press to save the value (50.00) of b0-09. Then the control panel will automatically switch to display the next function code (b0-10);
- 12) Press to exit parameter edit status.

Flow chart is shown below:

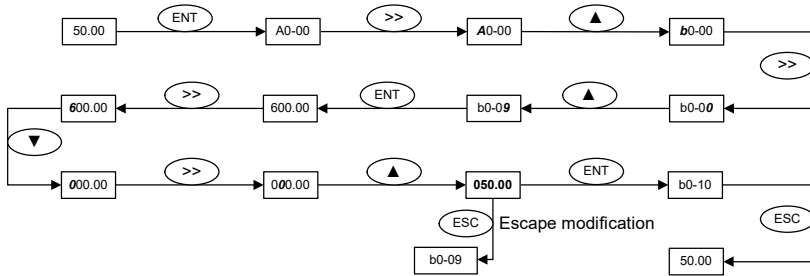

Fig. 4-12 Flow chart of upper limit frequency modification

◆ **Example 2:** user parameter initialization

- 1) In non-parameter edit status, press to display current parameter A0-00;
- 2) Press three times to change "0" in the rightmost bit of A0-00 to "3";
- 3) Press to display parameter value 0 of A0-03;
- 4) Press once to change "0" to "2" or "3" ("2" motor parameter excluded, "3" means motor parameter included);
- 5) Press to save the value of A0-03. Then control panel will automatically display parameter A0-00;
- 6) Press to escape parameter edit status.

Flow chart is shown below:

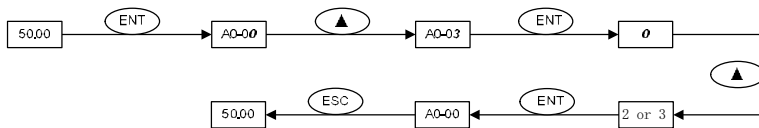

Fig. 4-13 Flow chart of user parameter initialization

◆ **Example 3:** setting method of hexadecimal parameter

Take L1-02 (LED STOP display parameter) for example, if LED control panel is required to display: setting frequency, bus voltage, AI1, running linear speed, and setting linear speed. Since all bits are independent of each other, the ones place, tens place, hundreds place and thousands place should be set separately. Determine the binary numbers of each bit and then convert the binary numbers into a hexadecimal number. See Table 4-6, the corresponding relation between binary numbers and a hexadecimal number.

Table 4-6 Corresponding relation between binary and hexadecimal

Binary numbers				Hexadecimal (LED bit display value)
BIT3	BIT2	BIT1	BIT0	
0	0	0	0	0
0	0	0	1	1
0	0	1	0	2
0	0	1	1	3
0	1	0	0	4
0	1	0	1	5
0	1	1	0	6
0	1	1	1	7
1	0	0	0	8
1	0	0	1	9
1	0	1	0	A
1	0	1	1	B
1	1	0	0	C
1	1	0	1	D
1	1	1	0	E
1	1	1	1	F

Set the value in the ones place:

As shown in Fig. 4-14, "setting frequency" and "bus voltage" are respectively determined by BIT0 and BIT1 in ones place of L1-02. If BIT0=1, setting frequency will be displayed. The bits that correspond to the parameters which are not required to display shall be set to 0. Therefore, the value in ones place should be 0011, corresponding to 3 in a hexadecimal number. Set the ones place to 3.

Set the value in tens place:

As shown in Fig. 4-14, since it is required to display "AI1", the binary set value of tens place is 0001, corresponding to 1 in a hexadecimal number. Thus, bit of tens place shall be set to 1.

Set the value in hundreds place:

As shown in Fig. 4-14, the parameter required to display does not involve hundreds place, so the hundreds place shall be set to zero.

Set thousands place:

As shown in Fig. 4-14, since required to display "running linear speed" and "setting linear speed", the binary set value of thousands place shall be 0011 that corresponds to 3 in a hexadecimal number.

To sum up, L1-02 should be set to 3013.

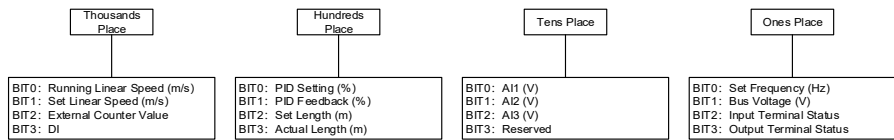

Fig. 4-14 Setting of hexadecimal parameter L1-02

Under parameter setting status, the parameter value cannot be modified if the value has no flashing digit. Possible causes include:

- 1) The parameter cannot be modified, such as actual detection parameters, running recording parameters, etc;
- 2) This parameter cannot be modified in run status but can be changed when motor stopped;
- 3) Parameter under protection. When parameter A0-02 is set to 1, parameters cannot be modified as the parameter protection against misoperation enabled. To edit parameter in such a circumstance, it is necessary to set A0-02 to 0 as first step.

4.1.4.4 Lock/Unlock Control Panel

● **Lock control panel**

All or some keys of CONTROL PANEL can be locked by any of the following three methods. See the definition of parameter L0-01 for further information.

Method 1: set the parameter value of L0-01 to non-zero, then press



Method 2: do not operate CONTROL PANEL within five minutes after L0-01 is set to non-zero.

Method 3: cut the power off and then apply power on after L0-01 parameter is set to non-zero.

Refer to flow chart 4-15 for locking CONTROL PANEL.

• **Unlock control panel**

To unlock the control panel, press **ESC** + **▶** + **▼** simultaneously. Unlocking won't change the value of parameter L0-01. In other words, the control panel will be locked again if the condition of locking control panel is fulfilled. To unlock the control panel completely, L0-01 value must be modified to 0 after unlocking.

Refer to flow chart 4- 16 of unlocking control panel

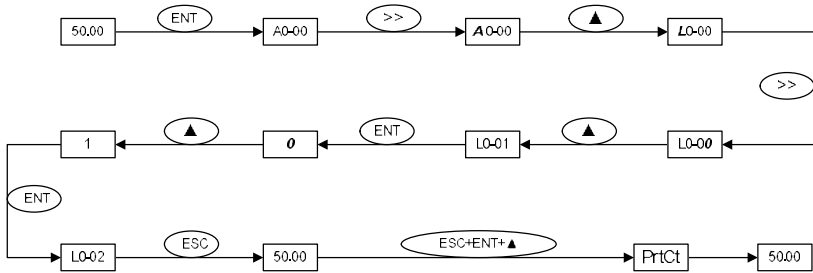

Fig. 4-15 Flow chart of locking control panel



Fig. 4-16 Flow chart of unlocking control panel

4.2 First-time Power up

Perform wiring in strict accordance with technical requirements as set forth in Chapter 3 - Installation and Wiring.

4.2.1 Flow chart of first-time power up of asynchronous motor

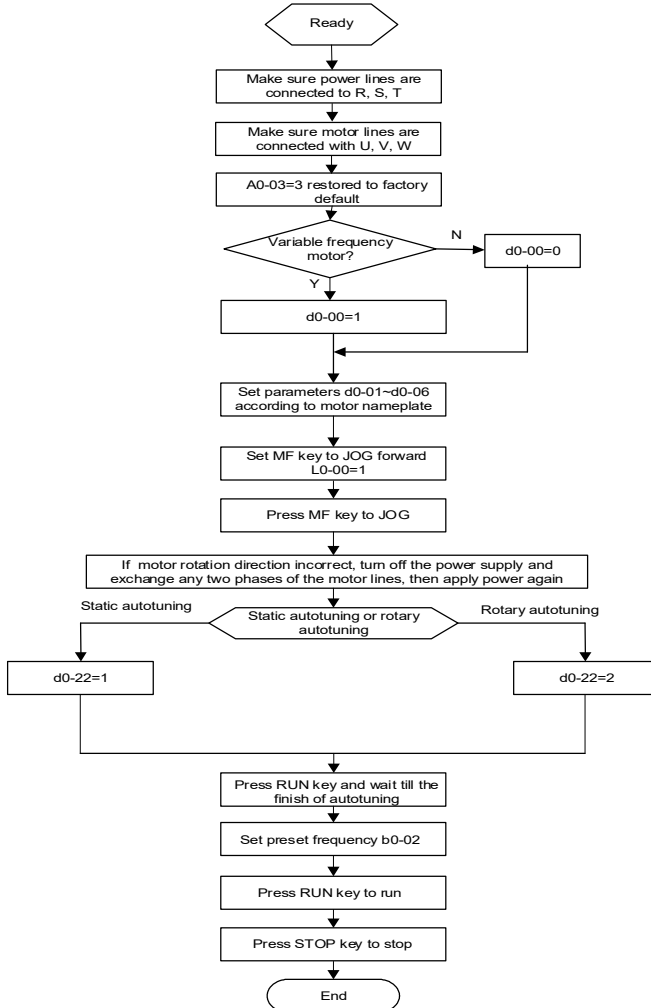

Fig. 4-17 Flow chart of first-time power up for asynchronous motor

4.2.2 Flow chart of first-time power up of synchronous motor

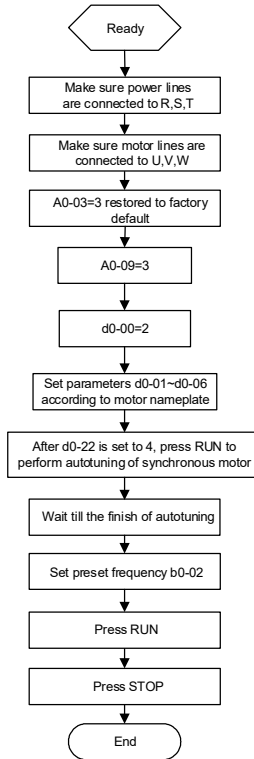

Fig. 4-18 Flow chart of first-time power up for synchronous motor

Chapter 5 List of Parameters

ABO620 parameter groups are listed below:

Category	Parameter group	Reference page
Group A: system parameters and parameter management	A0: system parameters	P75; P121
	A1: user-defined display parameters	P76; P124
Group b: Run parameter setting	b0: frequency setting	P78; P127
	b1: start/stop control	P79; P140
	b2: Accel/Decel parameters	P81; P146
Group C: input and output terminals	C0: digital input	P82; P152
	C1: digital output	P85; P165
	C2: analog and pulse input	P87; P172
	C3: analog and pulse output	P88; P177
	C4: automatic correction of analog input	P90; P182
Group d: motor and control parameters	d0: parameters of motor 1	P90; P183
	d1: V/f control parameters of motor 1	P92; P188
	d2: vector control parameters of motor 1	P93; P195
	d3: parameters of motor 2	P94; P199
	d4: V/f control parameters of motor 2	P96; P200
	d5: vector control parameters of motor 2	P97; P201
Group E: enhanced function and protection parameters	E0: enhanced function	P98; P203
	E1: protection parameters	P99; P207
Group F: application	F0: process PID	P102; P211
	F1: multi-step frequency	P103; P217
	F2: simple PLC	P105; P220
	F3: wobble frequency and fixed length count	P108; P229
	F5: vector control without PG for synchronous motor	P109; P233
Group H: communication parameters	H0: MODBUS communication parameters	P110; P235
	H1: Profibus-DP communication parameters	P111; P237
Group L: keys and display of control panel	L0: keys of control panel	P113; P237
	L1: control panel display setting	P113; P239
Group U: monitoring	U0: status monitoring	P115; P241
	U1: history fault	P118; P245

ATTENTION:

Change attribute:

"△" means the value of this parameter can be modified in stop and run status of drive;

"×" means the value of this parameter cannot be modified when drive is running;

"◎" means this parameter is a measured value that cannot be modified;

Factory default: The value when restored to factory default. Neither measured parameter value nor recorded value will be restored.

Scope: the scope of setting and display of parameter values

Parameter	Designation	Scope	Factory default	Attr
Group A: System Parameters and Parameter Management				
Group A0: System Parameters				
A0-00	Setting of user password	0~FFFF	0000	△
A0-01	Parameter display	0: Display all parameters 1: Only display A0-00 and A0-01 2: Only display A0-00, A0-01 and user-defined A1-00~A1-19 3: Only display A0-00, A0-01, and the parameters different from factory default	0	△
A0-02	Parameter protection	0: All parameter programming allowed 1: Only A0-00 and this parameter programming allowed	0	×
A0-03	Parameter restoration	0: No operation 1: Clear fault record 2: Restore all parameters to factory default (excluding motor parameters) 3: Restore all parameters to factory default (including motor parameters) 4: Restore all parameters to backup parameters	0	×
A0-04	Parameter backup	0: No operation 1: Backup all parameters	0	×
A0-05	Parameter copy	0: No operation 1: Parameter copied to control panel 2: Parameter copied (excluding motor parameters) to control board 3: Parameter copied (including motor parameters) to control board	0	×

Parameter	Designation	Scope	Factory default	Attr
A0-06	Type of drive	0: Type G (applicable to constant-torque load) 1: Type L (applicable to light-duty load)	0	×
A0-07	Power supply type of SMPS	0: Supplied by DC bus voltage of drive main circuit 1: Supplied independently	0	◎
A0-08	Motor 1 / motor 2 selection	0: Motor 1 1: Motor 2	0	×
A0-09	Motor control technique	Ones place: motor 1 control technique 0: V/f control 1: Sensor-less vector control 1 2: Sensor-less vector control 2 Tens place: motor 2 control technique 0: V/f control 1: Sensor-less vector control 1 2: Sensor-less vector control 2	00	×
Group A1: User-defined Display Parameters				
A1-00	User-defined display parameter 1	Setting range of thousands place: A, b, C, d, E, F, H, L, U Setting range of hundreds place: 0~9 Setting range of tens place: 0~9 Setting range of ones place: 0~9	A0-00	×
A1-01	User-defined display parameter 2		A0-00	×
A1-02	User-defined display parameter 3		A0-00	×
A1-03	User-defined display parameter 4		A0-00	×
A1-04	User-defined display parameter 5		A0-00	×
A1-05	User-defined display parameter 6		A0-00	×
A1-06	User-defined display parameter 7		A0-00	×
A1-07	User-defined display parameter 8		A0-00	×
A1-08	User-defined display parameter 9		A0-00	×
A1-09	User-defined display parameter 10		A0-00	×
A1-10	User-defined display parameter 11		A0-00	×

Parameter	Designation	Scope	Factory default	Attr
A1-11	User-defined display parameter 12		A0-00	×
A1-12	User-defined display parameter 13		A0-00	×
A1-13	User-defined display parameter 14		A0-00	×
A1-14	User-defined display parameter 15		A0-00	×
A1-15	User-defined display parameter 16		A0-00	×
A1-16	User-defined display parameter 17		A0-00	×
A1-17	User-defined display parameter 18		A0-00	×
A1-18	User-defined display parameter 19		A0-00	×
A1-19	User-defined display parameter 20		A0-00	×
A1-20	Parameter group display/hide setting 1	0~FFFF	FFFF	×
A1-21	Parameter group display/hide setting 2	0~FFFF	FFFF	×
A1-22	Fault masking	0~FF Ones: binary Bit3Bit2Bit1Bit0 Bit set 0:unmask; 1: mask Bit0: GdP fault Bit1: SP1 fault Bit2: SP2 fault Bit3: CPU fault Tens: binary Bit3Bit2Bit1Bit0 Bit set 0:unmask; 1: mask Bit0: AIP fault Bit1: OL3 fault Bit2: oCR fault Bit3: reserved Example: if faults of GdP, SP1, SP2, CPU need to be masked, then set ones as hexadecimal F (set binary Bit3Bit2Bit1Bit0 as 1). And it is similar meaning for tens	08	△

Parameter	Designation	Scope	Factory default	Attr
Group b Run Parameter Setting				
Group b0 Frequency Setting				
b0-00	FREQ set mode	0: Master FREQ set 1: Master & auxiliary computation result 2: Switch between master and auxiliary set 3: Switch between master FREQ set, and master & auxiliary computation result 4: Switch between auxiliary FREQ set, and master & auxiliary computation result	0	×
b0-01	Master FREQ set	0: Digital setting (b0-02) + \wedge / \vee adjustment on control panel 1: Digital setting (b0-02) + terminal UP/DOWN adjustment 2: Analog input AI1 3: Analog input AI2 4: Analog input EAI (on IO option) 5: X6/DI pulse input 6: Process PID output 7: PLC 8: Multi-step speed 9: Communication	0	×
b0-02	Master FREQ digital setting	Lower limit freq ~ upper limit freq	50.00Hz	Δ
b0-03	Auxiliary FREQ set	0: No setting 1: Digital setting (b0-04) + \wedge / \vee adjustment on control panel 2: Digital setting (b0-04) + terminal UP/DOWN adjustment 3: Analog input AI1 4: Analog input AI2 5: Analog input EAI (on IO option board) 6: X6/DI pulse input 7: Process PID output 8: PLC 9: Multi-step speed 10: Communication	0	×
b0-04	Auxiliary FREQ digital setting	Lower limit FREQ ~ upper limit FREQ	0.00Hz	Δ

Parameter	Designation	Scope	Factory default	Attr
b0-05	Auxiliary FREQ range	0: Relative to maximum FREQ 1: Relative to master FREQ	0	×
b0-06	Auxiliary FREQ coeff	0.0%~100.0%	100.0%	×
b0-07	Computation of master and auxiliary FREQ	0: Master + auxiliary 1: Master - auxiliary 2: Max {master, auxiliary} 3: Min {master, auxiliary}	0	×
b0-08	Maximum FREQ	Upper limit FREQ ~600.00Hz	50.00Hz	×
b0-09	Upper limit FREQ	Lower limit FREQ ~ maximum FREQ	50.00Hz	×
b0-10	Lower limit FREQ	0.00Hz~upper limit FREQ	0.00Hz	×
b0-11	Operation when set FREQ lower than lower limit FREQ	0: Run at lower limit FREQ 1: Run at 0 Hz 2: Stop	0	×
b0-12	Time-delay of stop when set FREQ lower than lower limit FREQ	0.0s ~ 6553.5s	0.0s	×
b0-13	Lower limit of skip FREQ band 1	0.00Hz~upper limit FREQ	0.00Hz	×
b0-14	Upper limit of skip FREQ band 1	0.00Hz~upper limit FREQ	0.00Hz	×
b0-15	Lower limit of skip FREQ band 2	0.00Hz~upper limit FREQ	0.00Hz	×
b0-16	Upper limit of skip FREQ band 2	0.00Hz~upper limit FREQ	0.00Hz	×
b0-17	Lower limit of skip FREQ band 3	0.00Hz~upper limit FREQ	0.00Hz	×
b0-18	Upper limit of skip FREQ band 3	0.00Hz~upper limit FREQ	0.00Hz	×
b0-19	Jog FREQ	0.00Hz~upper limit FREQ	5.00Hz	△
b0-20	Zero clearing when master and auxiliary FREQ is switching	0~1 0: zero clearing 1: no zero clearing	0	△
Group b1 Start/Stop Control				
b1-00	Run command	0: Control panel control 1: Terminal control 2: Communication control	0	×

Parameter	Designation	Scope	Factory default	Attr
b1-01	Binding of run command and frequency set	Ones place: frequency set bundled under control panel control: 0: No binding 1: Digital setting (b0-02) + \wedge/\vee adjustment on control panel 2: Digital setting (b0-02) + terminal UP/DOWN adjustment 3: Analog input AI1 4: Analog input AI2 5: Analog input EAI (on IO option board) 6: X6/DI pulse input 7: Process PID output 8: Simple PLC 9: Multi-step FREQ A: Communication input Tens place: FREQ set bundled under terminal control (same as ones place) Hundreds place: FREQ set bundled under communication control (same as ones place)	000	×
b1-02	Run direction	0: Forward 1: Reverse	0	Δ
b1-03	Reverse disabled	0: Reverse enabled 1: Reverse disabled	0	×
b1-04	Dead time between forward and reverse	0.0s~3600.0s	0.0s	Δ
b1-05	Start method	0: From start FREQ 1: DC braking start 2: Flying start 1 3: Flying start 2 4: Flying start 3 5: Flying start 4 Note A: need flying start option board EPC-VD2 for flying start 2 Note B: Normally flying start 4 is used for SW search at best effect	0	×
b1-06	Start FREQ	0.00Hz~upper limit FREQ	0.00Hz	×
b1-07	Holding time of start FREQ	0.0s~3600.0s	0.0s	Δ
b1-08	DC braking current at start	0.0%~200.0%	0.0%	Δ
b1-09	DC braking time at start	0.00s~30.00s	0.00s	Δ

Parameter	Designation	Scope	Factory default	Attr
b1-10	Flying start 1 current	0.0~200.0%	100.0%	×
b1-11	Flying start 1 Decel time	0.1s~20.0s	2.0s	×
b1-12	Flying start 1 adjustment coeff	0.0~100.0%	1.0%	×
b1-13	Stop method	0: Ramp to stop 1: Coast to stop 2: Ramp to stop + DC brake	0	×
b1-14	Start FREQ of DC brake stop	0.00Hz~upper limit FREQ	0.00Hz	×
b1-15	DC brake current	0.0%~200.0%	0.0%	△
b1-16	DC brake time	0.00s~30.00s	0.00s	△
b1-17	Overexcitation brake	0: Disabled 1: Enabled	1	×
b1-18	Dynamic brake	0: Disabled 1: Enabled	0	×
b1-19	Dynamic brake threshold voltage	650V~750V	720V	×
b1-20	Auto restart when power up again after power loss	0: Disabled 1: Enabled	0	×
b1-21	Time delay of auto restart when power up again	0.0s~10.0s	0.0s	△
Group b2 Accel/Decel Parameters				
b2-00	Accel/Decel time resolution	0:0.01s 1:0.1s 2:1s	1	×
b2-01	Accel time 1	0s~600.00s/6000.0s/60000s	6.0s	△
b2-02	Decel time 1	0s~600.00s/6000.0s/60000s	6.0s	△
b2-03	Accel time 2	0s~600.00s/6000.0s/60000s	6.0s	△
b2-04	Decel time 2	0s~600.00s/6000.0s/60000s	6.0s	△
b2-05	Accel time 3	0s~600.00s/6000.0s/60000s	6.0s	△
b2-06	Decel time 3	0s~600.00s/6000.0s/60000s	6.0s	△
b2-07	Accel time 4	0s~600.00s/6000.0s/60000s	6.0s	△
b2-08	Decel time 4	0s~600.00s/6000.0s/60000s	6.0s	△
b2-09	Decel time for emergency stop	0s~600.00s/6000.0s/60000s	6.0s	△
b2-10	Jog Accel time	0s~600.00s/6000.0s/60000s	6.0s	△
b2-11	Jog Decel time	0s~600.00s/6000.0s/60000s	6.0s	△
b2-12	Accel/Decel curve	0: Linear Accel/Decel 1: Broken-line Accel/Decel 2: S-curve Accel/Decel A	0	×

Parameter	Designation	Scope	Factory default	Attr
		3: S-curve Accel/Decel B 4: S-curve Accel/Decel C		
b2-13	Accel time switching FREQ of broken-line Accel/Decel	0.00Hz~upper limit FREQ	0.00Hz	△
b2-14	Decel time switching FREQ of broken-line Accel/Decel	0.00Hz~upper limit FREQ	0.00Hz	△
b2-15	Time of Accel S-curve first segment	0.00s~60.00s (S-curve A)	0.20s	△
b2-16	Time of Accel S-curve last segment	0.00s~60.00s (S-curve A)	0.20s	△
b2-17	Time of Decel S-curve first segment	0.00s~60.00s (S-curve A)	0.20s	△
b2-18	Time of Decel S-curve last segment	0.00s~60.00s (S-curve A)	0.20s	△
b2-19	Proportion of Accel S-curve first segment	0.0%~100.0% (S-curve B)	20.0%	△
b2-20	Proportion of Accel S-curve last segment	0.0%~100.0% (S-curve B)	20.0%	△
b2-21	Proportion of Decel S-curve first segment	0.0%~100.0% (S-curve B)	20.0%	△
b2-22	Proportion of Decel S-curve last segment	0.0%~100.0% (S-curve B)	20.0%	△
Group C Input and Output Terminals				
Group C0 Digital Input				
C0-00	Enabled condition of run command terminals when power up	0: Trigger edge detected + ON detected 1: ON detected	0	×
C0-01	Function of terminal X1	0: No function 1: JOG forward	3	×
C0-02	Function of terminal X2	2: JOG reverse 3: Run forward (FWD)	4	×
C0-03	Function of terminal X3	4: Run reverse (REV) 5: Three-wire control	1	×
C0-04	Function of terminal X4	6: Run suspended 7: External stop	23	×
C0-05	Function of terminal X5	8: Emergency stop 9: Stop command + DC brake	11	×
C0-06	Function of terminal X6/DI	10: DC brake stop 11: Coast to stop 12: Terminal UP	0	×
C0-07	Function of terminal EX	13: Terminal DOWN	0	×

Parameter	Designation	Scope	Factory default	Attr
	(on IO option board)	14: Clear UP/DOWN (including \wedge/\vee key) adjustment		
C0-08	Function of terminal AI1 (Digital enabled)	15: Multi-step FREQ terminal 1	0	×
C0-09	Function of terminal AI2 (Digital enabled)	16: Multi-step FREQ terminal 2 17: Multi-step FREQ terminal 3 18: Multi-step FREQ terminal 4	0	×
C0-10	Function of terminal EAI (Digital enabled) (on IO option board)	19: Accel/Decel time determinant 1 20: Accel/Decel time determinant 2 21: Accel/Decel disabled(ramp stop not inclusive) 22: External fault input 23: Fault reset (RESET) 24: Pulse input (valid only for X6/DI) 25: Motor 1/2 switchover 26: Reserved 27: Run command switched to control panel control 28: Run command switched to terminal control 29: Run command switched to communication control 30: Frequency set mode shift 31: Master FREQ set switched to digital setting b0-02 32: Auxiliary FREQ set switched to digital setting b0-04 33: PID adjustment direction 34: PID paused 35: PID integration paused 36: PID parameter switch 37: Count input 38: Count clear 39: Length count 40: Length clear 41~62: Reserved 63: Simple PLC paused 64: Simple PLC disabled 65: Simple PLC stop memory clear 66: Start wobble frequency 67: Clear wobble frequency status 68: Run prohibited 69: DC brake in run	0	×

Parameter	Designation	Scope	Factory default	Attr
		70: Analog input curve switching 71~99: Reserved		
C0-11	Filtering time of digital input terminal	0.000s~1.000s	0.010s	△
C0-12	Delay time of terminal X1	0.0s~3600.0s	0.0s	△
C0-13	Delay time of terminal X2	0.0s~3600.0s	0.0s	△
C0-14	Digital input terminal enabled status setting 1	Ones place: X1 0: Positive logic 1: Negative logic Tens place: X2 (same as ones place) Hundreds place: X3 (same as ones place) Thousands place: X4 (same as ones place)	0000	×
C0-15	Digital input terminal enabled status setting 2	Ones place: X5 0: Positive logic 1: Negative logic Tens place: X6 (valid as ordinary terminal, same as ones place) Hundreds place: (on IO option board, same as ones place) Thousands place: reserved	0000	×
C0-16	Digital input terminal enabled status setting 3	Ones place: AI1 0: Positive logic 1: Negative logic Tens place: AI2 (same as ones place) Hundreds place: EAI (on IO option board, same as ones place) Thousands place: reserved	0000	×
C0-17	Terminal UP/DOWN FREQ adjustment action	Ones place: at stop 0: Cleared 1: Maintained Tens place: on power loss 0: Cleared 1: Maintained Hundreds place: integral function 0: No integral function 1: Integral function enabled Thousands place: run direction 0: Changing run direction prohibited 1: Changing run direction allowed	0000	△

Parameter	Designation	Scope	Factory default	Attr
C0-18	Terminal UP/DOWN frequency change step size	0.00Hz/s~100.00Hz/s	0.03 Hz/s	△
C0-19	FWD/REV terminal control mode	0: Two-wire mode 1 1: Two-wire mode 2 2: Three-wire mode 1 3: Three-wire mode 2	0	×
C0-20	Option of virtual input terminal	000~77F 0: Actual terminal in effect 1: Virtual terminal in effect Ones place: BIT0~BIT3: X1~X4 Tens place: BIT4~BIT6: X5~X6, EX Hundreds place: BIT8~BIT10: AI1~AI2, EAI (EX and EAI located at IO option board)	000	×
C0-21	Enabled condition of run command terminal after fault reset (RESET)	0: Trigger edge detected + ON detected 1: ON detected	0	△
Group C1 Digital Output				
C1-00	Y1 output function	0: No output	0	△
C1-01	Y2/DO output function (when used as Y2)	1: Drive undervoltage 2: Drive run preparation completed	0	△
C1-02	Control board relay output function	3: Drive is running 4: Drive running at 0Hz (there is no output at stop) 5: Drive running at 0Hz (there is output at stop) 6: Run direction 7: FREQ attained 8: Upper limit FREQ attained 9: Lower limit FREQ attained 10: Frequency detection FDT1 11: Frequency detection FDT2 12: Reserved 13: Torque limited 14: Fault output 15: Alarm output 16: Drive (motor) overloaded alarm 17: Drive overheat alarm 18: Zero current detection 19: X1 20: X2	14	△
C1-03	Option board relay output function		15	△

Parameter	Designation	Scope	Factory default	Attr
		21: Motor 1/ 2 indication 22: Set count value attained 23: Designated count value attained 24: Length attained 25: Consecutive run time attained 26: Accumulative run time attained 27: Brake control 28: Reserved 29: Reserved 30: PLC step completed 31: PLC cycle completed 32: Wobble frequency attains to upper or lower limit frequency 33: Upper/lower limit of set FREQ attained 34: Target FREQ attained (set by C2-29) 35~99: Reserved		
C1-04	Y1 output time delay	0.0s~3600.0s	0.0s	△
C1-05	Y2 output time delay	0.0s~3600.0s	0.0s	△
C1-06	Control board relay output time delay	0.0s~3600.0s	0.0s	△
C1-07	Option board relay output time delay	0.0s~3600.0s	0.0s	△
C1-08	Enabled state of digital output	Ones place: Y1 0: Positive logic 1: Negative logic Tens place: Y2 (same as ones place) Hundreds place: control board relay output (same as ones place) Thousands place: option board relay output (same as ones place)	0000	×
C1-09	Detected object of FREQ detection (FDT)	Ones place: FDT1 detected object 0: Speed set value (FREQ after Accel/Decel) 1: Detected speed value Tens place: FDT2 detected object 0: Speed set value (FREQ after Accel/Decel) 1: Detected speed value	00	△
C1-10	FDT1 upper value	0.00Hz~maximum FREQ	50.00Hz	△
C1-11	FDT1 lower value	0.00Hz~maximum FREQ	49.00Hz	△

Parameter	Designation	Scope	Factory default	Attr
C1-12	FDT2 upper value	0.00Hz~maximum FREQ	25.00Hz	△
C1-13	FDT2 lower value	0.00Hz~maximum FREQ	24.00Hz	△
C1-14	Detection width of FREQ attained	0.00Hz~maximum FREQ	2.50Hz	△
C1-15	Zero current detection value	0.0%~50.0%	5.0%	△
C1-16	Zero current detection time	0.01s~50.00s	0.50s	△
Group C2 Analog and Pulse Input				
C2-00	Analog input curve	Ones place: AI1 input curve 0: Curve 1 (2 points) 1: Curve 2 (4 points) 2: Curve 3 (4 points) 3: Curve 2 and curve 3 switchover Tens place: AI2 input curve (same as ones place) Hundreds place: EAI input curve (same as ones place) Thousands place: reserved	0210	×
C2-01	Curve 1 maximum input	Curve 1 minimum input ~ 110.0%	100.0%	△
C2-02	Corresponding set value of curve 1 maximum input	-100.0%~100.0%	100.0%	△
C2-03	Curve 1 minimum input	-110.0% ~ curve 1 maximum input	0.0%	△
C2-04	Corresponding set value of curve 1 minimum input	-100.0%~100.0%	0.0%	△
C2-05	Curve 2 maximum input	Range: input of curve 2 inflection point A~110.0%	100.0%	△
C2-06	Set value corresponding to curve 2 maximum input	Range: -100.0%~100.0%	100.0%	△
C2-07	Input of curve 2 inflection point A	Input of curve 2 inflection point B ~ curve 2 maximum input	0.0%	△
C2-08	Set value Cor. to input of curve 2 inflection point A	Range: -100.0%~100.0%	0.0%	△
C2-09	Input of curve 2 inflection point B	Range: Curve 2 minimum input ~ Input of curve 2 inflection point A	0.0%	△
C2-10	Set value corresponding to input of curve 2 inflection point B	Range: -100.0%~100.0%	0.0%	△

Parameter	Designation	Scope	Factory default	Attr
C2-11	Curve 2 minimum input	Range: -110.0%~ input of curve 2 inflection point B	-100.0%	△
C2-12	Set value corresponding to curve 2 minimum input	Range: -100.0%~100.0%	-100.0%	△
C2-13	Curve 3 maximum input	Range: input of curve 3 inflection point A ~110.0%	100.0%	△
C2-14	Set value corresponding to curve 3 maximum input	Range: -100.0%~100.0%	100.0%	△
C2-15	Input of curve 3 inflection point A	Range: input of curve 3 inflection point B ~ curve 3 maximum input	0.0%	△
C2-16	Set value corresponding to input of curve 3 inflection point A	Range: -100.0%~100.0%	0.0%	△
C2-17	Input of curve 3 inflection point B	Range: curve 3 minimum input~ input of curve 3 inflection point A	0.0%	△
C2-18	Set value corresponding to input of curve 3 inflection point B	Range: -100.0%~100.0%	0.0%	△
C2-19	Curve 3 minimum input	Range: -110.0%~ input of curve 3 inflection point B	0.0%	△
C2-20	Set value corresponding to curve 3 minimum input	Range: -100.0%~100.0%	0.0%	△
C2-21	AI1 terminal filtering time	0.000s~10.000s	0.1s	△
C2-22	AI2 terminal filtering time	0.000s~10.000s	0.1s	△
C2-23	EAI terminal filtering time (on IO option board)	0.000s~10.000s	0.1s	△
C2-24	DI maximum input	Range: C2-26~50.0kHz	50.0kHz	△
C2-25	Set value corresponding to DI maximum input	Range: -100.0%~100.0%	100.0%	△
C2-26	DI minimum input	Range: 0.0kHz~C2-24	0.0kHz	△
C2-27	Set value corresponding to DI minimum input	Range: -100.0%~100.0%	0.0%	△
C2-28	DI filtering time	0.000s~1.000s	0.001s	△
C2-29	Target FREQ	0.00Hz~upper limit FREQ (enabled when C1-00 ~C1-03 is set to 34)	0.00Hz	△
Group C3 Analog and Pulse Output				
C3-00	AO1 output function	0: No output	2	△
C3-01	EAO output function (on IO option)	1: Set FREQ 2: Output FREQ	1	△

Parameter	Designation	Scope	Factory default	Attr
C3-02	Y2/DO output function (when used as DO)	3: Output current (to drive rated) 4: Output torque (absolute value) 5: Output voltage 6: Output power 7: Bus voltage 8: Reserved 9: Torque current 10: Magnetic flux current 11:AI1 12:AI2 13:EAI 14: Reserved 15:DI 16:Communication input percentage 17: Output FREQ before compensation 18:Output current (relative to motor rated current) 19:Output torque (direction hinted) 20:Set torque (direction hinted) 21~99: Reserved	0	△
C3-03	AO1 offset	-100.0%~100.0%	0.0%	×
C3-04	AO1 gain	-2.000~2.000	1.000	×
C3-05	AO1 filtering time	0.0s~10.0s	0.0s	△
C3-06	EAO offset	-100.0%~100.0%	0.0%	×
C3-07	EAO gain	-2.000~2.000	1.000	×
C3-08	EAO filtering time	0.0s~10.0s	0.0s	△
C3-09	DO maximum output pulse FREQ	0.1kHz~50.0kHz	50.0kHz	△
C3-10	DO output center point	0: No center point 1: Center point is (C3-09)/2, and the corresponding parameter value is positive when FREQ is higher than center point 2: Center point is (C3-09)/2, and the corresponding parameter value is positive when FREQ is lower than center point	0	×
C3-11	DO output filtering time	0.00s~10.00s	0.00s	△

Parameter	Designation	Scope	Factory default	Attr
Group C4 Automatic Correction of Analog Input				
C4-00	Analog correction	0: No correction 1:Correct AI1 2:Correct AI2 3:Correct EAI	0	×
C4-01	Sampling value of AI1 calibration point 1	Range: 0.00V~10.00V	1.00V	◎
C4-02	Input value of AI1 calibration point 1	Range: 0.00V~10.00V	1.00V	×
C4-03	Sampling value of AI1 calibration point 2	Range: 0.00V~10.00V	9.00V	◎
C4-04	Input value of AI1 calibration point 2	Range: 0.00V~10.00V	9.00V	×
C4-05	Sampling value of AI2 calibration point 1	Range: -10.00V~10.00V	1.00V	◎
C4-06	Input value of AI2 calibration point 1	Range: -10.00V~10.00V	1.00V	×
C4-07	Sampling value of AI2 calibration point 2	Range: -10.00V~10.00V	9.00V	◎
C4-08	Input value of AI2 calibration point 2	Range: -10.00V~10.00V	9.00V	×
C4-09	Sampling value of EAI calibration point 1	Range: 0.00V~10.00V	1.00V	◎
C4-10	Input value of EAI calibration point 1	Range: 0.00V~10.00V	1.00V	×
C4-11	Sampling value of EAI calibration point 2	Range: 0.00V~10.00V	9.00V	◎
C4-12	Input value of EAI calibration point 2	Range: 0.00V~10.00V	9.00V	×
Group d Motor and Control Parameters				
Group d0 Parameters of Motor 1				
d0-00	Type of motor 1	0: Ordinary asyn. motor 1: Variable frequency asyn. motor 2: Synchronous motor	1	×
d0-01	Power rating of motor 1	0.4kW~6553.5kW	Model dependent	×
d0-02	Rated voltage of motor 1	0V~480V (for drives 400V level)	380V	×
d0-03	Rated current of motor 1	0.0A~6553.5A	Model dependent	×

Parameter	Designation	Scope	Factory default	Attr
d0-04	Rated frequency of motor 1	0.00Hz~upper limit frequency	50.00Hz	×
d0-05	Pole number of motor 1	1~80	4	×
d0-06	Rated speed of motor 1	0~65535r/min	Model dependent	×
d0-07	Stator resistance R1 of asyn. motor 1	0.001Ω~65.535Ω	Model dependent	×
d0-08	Leakage inductance L1 of asyn. motor 1	0.1mH~6553.5mH	Model dependent	×
d0-09	Rotor resistance R2 of asyn. motor 1	0.001Ω~65.535Ω	Model dependent	×
d0-10	Mutual inductance L2 of asyn. motor 1	0.1mH~6553.5mH	Model dependent	×
d0-11	No-load current of asyn. motor 1	0.0A~6553.5A	Model dependent	×
d0-12	Flux weakening coeff 1 of asyn. motor 1	0.0000~1.0000	Model dependent	×
d0-13	Flux weakening coeff 2 of asyn. motor 1	0.0000~1.0000	Model dependent	×
d0-14	Flux weakening coeff 3 of asyn. motor 1	0.0000~1.0000	Model dependent	×
d0-15	Stator resistance of syn. motor 1	0.001Ω~65.535Ω	0.500Ω	×
d0-16	D-axis inductance of syn. motor 1	0.01mH~655.35mH	9.00 mH	×
d0-17	Q-axis inductance of syn. motor 1	0.01mH~655.35mH	9.00 mH	×
d0-18	Back EMF voltage of syn. motor 1	0.0V~1000.0V	380.0V	×
d0-19	Autotuning current of syn. motor 1	0.0%~100.0% 100% is rated current of motor	35.0%	×
d0-20	Reserved	Reserved	Reserved	×
d0-21	Reserved	Reserved	Reserved	×
d0-22	Autotuning of motor 1	0: Disabled 1: Static autotuning of asyn. motor 2: Rotary autotuning of asyn. motor 3: Reserved 4: Static autotuning of syn. motor 5: No-load rotary autotuning of syn. motor	0	×

Parameter	Designation	Scope	Factory default	Attr
d0-23	Overload protection of motor 1	0: No protection 1: Judged by motor current 2: Judged by temperature transducer	1	×
d0-24	Overload protection detection time of motor 1	0.1min~15.0min	5.0min	×
d0-25	Temperature transducer signal input of motor 1	0: AI1 1: AI2 2: EAI (on IO optional board)	1	×
d0-26	Thermal protection threshold of motor 1 temperature transducer	0.00V~10.00V	10.00V	×
d0-27	SW rotary speed track Kp	0.00~655.35	0.00	×
d0-28	SW rotary speed track Ki	0.00~655.35	2.00	×
Group d1 V/f Control Parameters of Motor 1				
d1-00	V/f curve setting	0: Linear V/f 1: Multi-stage V/f (d1-01~d1-08) 2: 1.2nd power 3: 1.4th power 4: 1.6th power 5: 1.8th power 6: 2.0nd power 7: V/f separated mode 1 8: V/f separated mode 2	0	×
d1-01	V/f FREQ value f3	0.00Hz~motor rated FREQ	50.00Hz	×
d1-02	V/f voltage value V3	0.0%~100.0%	100.0%	×
d1-03	V/f FREQ value f2	d1-05~d1-01	0.00Hz	×
d1-04	V/f voltage value V2	0.0%~100.0%	0.0%	×
d1-05	V/f FREQ value f1	d1-07~d1-03	0.00Hz	×
d1-06	V/f voltage value V1	0.0%~100.0%	0.0%	×
d1-07	V/f FREQ value f0	0.00Hz~d1-05	0.00Hz	×
d1-08	V/f voltage value V0	0.0%~100.0%	0.0%	×
d1-09	Torque boost	0.0%~30.0%	0.0%	△
d1-10	Slip compensation gain	0.0%~400.0%	100.0%	△
d1-11	Droop control	0.00Hz~maximum FREQ	0.00Hz	△
d1-12	Current limitation mode	0: Disabled 1: Set by d1-13 2: Set by AI1 3: Set by AI2 4: Set by EAI 5: Set by X6/DI	1	×

Parameter	Designation	Scope	Factory default	Attr
d1-13	Digital setting of current limit value	20.0%~200.0%	160.0%	×
d1-14	Current limit coeff on flux weakening	0.001~1.000	0.500	△
d1-15	Energy saving percentage	0%~40.0%	0.0%	△
d1-16	V/f oscillation suppression gain 1	0~3000	38	△
d1-17	V/f oscillation suppression gain 2	0~3000	0	△
d1-18	Voltage setting on V/f separated pattern	0: d1-19 digital setting 1: Set by AI1 2: Set by AI2 3: Set by EAI 4: Process PID output 5: AI1 + process PID output	0	×
d1-19	Digital set voltage on V/f separated pattern	0.0%~100.0%	0.0%	△
d1-20	Voltage variation time on V/f separated pattern	0.00s~600.00s	0.01s	△
Group d2 Vector Control Parameters of Motor 1				
d2-00	Reserved	Reserved	0	×
d2-01	ASR high-speed proportional gain Kp1	0.0~20.0	2.0	△
d2-02	ASR high-speed integration time Ti1	0.000s~8.000s	0.200	△
d2-03	ASR low-speed proportional gain Kp2	0.0~20.0	2.0	△
d2-04	ASR low-speed integration time Ti2	0.000s~8.000s	0.200	△
d2-05	ASR switching FREQ 1	0.00Hz~d2-06	5.00Hz	△
d2-06	ASR switching FREQ 2	d2-05~upper limit FREQ	10.00Hz	△
d2-07	ASR input filtering time	0.0ms~500.0ms	5.0ms	△
d2-08	ASR output filtering time	0.0ms~500.0ms	0.3ms	△
d2-09	ACR proportion coeff Kp	0.000~4.000	1.000	△
d2-10	ACR integration coeff Ki	0.000~4.000	1.000	△
d2-11	Pre-excitation time	0.000s~5.000s	0.200s	△

Parameter	Designation	Scope	Factory default	Attr
d2-12	Driven torque restriction source	0: d2-14 digital setting 1: AI1 2: AI2 3: EAI (on IO option board) 4: X6/DI pulse input 5: Communication	0	×
d2-13	Braking torque restriction source	0: d2-15 digital setting 1: AI1 2: AI2 3: EAI (on IO option board) 4: X6/DI pulse input 5: Communication	0	×
d2-14	Digital setting of driven torque	0.0%~200.0%	180.0%	△
d2-15	Digital setting of braking torque	0.0%~200.0%	180.0%	△
d2-16	Torque limit coefficient in flux weakening	0.0%~100.0%	50.0%	△
d2-17	Driven slip compensation gain	10.0%~300.0%	100.0%	△
d2-18	Brake slip compensation gain	10.0%~300.0%	100.0%	△
Group d3 Parameters of Motor 2				
d3-00	Type of motor 2	0: Ordinary asyn. motor 1: Variable-frequency asyn. motor 2: Synchronous motor	0	×
d3-01	Power rating of motor 2	0.4kW~6553.5kW	Model dependent	×
d3-02	Rated voltage of motor 2	0V~480V (for drives 400V level)	380V	×
d3-03	Rated current of motor 2	0.0A~6553.5A	Model dependent	×
d3-04	Rated frequency of motor 2	0.00Hz~upper limit frequency	50.00Hz	×
d3-05	Pole number of motor 2	1~80	4	×
d3-06	Rated speed of motor 2	0~65535r/min	Model dependent	×
d3-07	Stator resistance R1 of asyn. motor 2	0.001Ω~65.535Ω	Model dependent	×
d3-08	Leakage inductance L1 of asyn. motor 2	0.1mH~6553.5mH	Model dependent	×
d3-09	Rotor resistance R2 of asyn. motor 2	0.001Ω~65.535Ω	Model dependent	×

Parameter	Designation	Scope	Factory default	Attr
d3-10	Mutual inductance L2 of asyn. motor 2	0.1mH~6553.5mH	Model dependent	×
d3-11	No-load current of asyn. motor 2	0.0A~6553.5A	Model dependent	×
d3-12	Flux weakening coeff 1 of asyn. motor 2	0.0000~1.0000	Model dependent	×
d3-13	Flux weakening coeff 2 of asyn. motor 2	0.0000~1.0000	Model dependent	×
d3-14	Flux weakening coeff 3 of asyn. motor 2	0.0000~1.0000	Model dependent	×
d3-15	Stator resistance of syn. motor 2	0.001Ω~65.535Ω	0.500Ω	×
d3-16	D-axis inductance of syn. motor 2	0.01mH~655.35mH	9.00 mH	×
d3-17	Q-axis inductance of syn. motor 2	0.01mH~655.35mH	9.00 mH	×
d3-18	Back EMF voltage of syn. motor 2	0.0V~1000.0V	380.0V	×
d3-19	Autotuning current of syn. motor 2	0.0%~100.0% 100% is rated current of motor	35.0%	×
d3-20	Reserved	Reserved	Reserved	×
d3-21	Reserved	Reserved	Reserved	×
d3-22	Autotuning of motor 2	0: Disabled 1: Static autotuning of asyn. motor 2: Rotary autotuning of asyn. motor 3: Reserved 4: Static autotuning of sync. motor 5: No-load rotary autotuning of sync. motor	0	×
d3-23	Overload protection mode of motor 2	0: No action 1: Judged by motor current 2: Judged by temperature transducer	1	×
d3-24	Overload protection detection time of motor 2	0.1min~15.0min	5.0min	×
d3-25	Input channel of motor 2 temperature transducer signal	0: AI1 1: AI2 2: EAI (on IO optional board)	0	×
d3-26	Thermal protection threshold of motor 2 temperature transducer	0.00V~10.00V	10.00V	×

Parameter	Designation	Scope	Factory default	Attr
d3-27	Single phase current overload point	0.0%~400.0%	150.0%	△
d3-28	Single phase current overload time	0.001~50.000s	1.000s	△
Group d4 V/f Control Parameter of Motor 2				
d4-00	V/f curve setting	0: Linear V/f 1: Various segments V/f (d4-01~d4-08) 2: 1.2nd power 3: 1.4th power 4: 1.6th power 5: 1.8th power 6: 2.0nd power 7: V/f separated mode 1 8: V/f separated mode 2	0	×
d4-01	V/f FREQ value f3	0.00Hz~rated FREQ of motor	50.00Hz	×
d4-02	V/f voltage value V3	0.0%~100.0%	100.0%	×
d4-03	V/f FREQ value f2	d4-05~d4-01	0.00Hz	×
d4-04	V/f voltage value V2	0.0%~100.0%	0.0%	×
d4-05	V/f FREQ value f1	d4-07~d4-03	0.00Hz	×
d4-06	V/f voltage value V1	0.0%~100.0%	0.0%	×
d4-07	V/f FREQ value f0	0.00Hz~d4-05	0.00Hz	×
d4-08	V/f voltage value V0	0.0%~100.0%	0.0%	×
d4-09	Torque boost	0.0%~30.0%	0.0%	△
d4-10	Slip compensation gain	0.0%~300.0%	100.0%	△
d4-11	Drooping FREQ of droop control	0.00Hz~maximum frequency	0.00Hz	△
d4-12	Current limitation source	0: Disabled 1: Set by d4-13 2: Set by AI1 3: Set by AI2 4: Set by EAI 5: Set by X6/DI	1	×
d4-13	Digital setting of current limit value	20.0%~200.0%	160.0%	×
d4-14	Flux weakening current limit coeff	0.001~1.000	0.500	△
d4-15	Energy saving percentage	0.0%~40.0%	0.0%	△
d4-16	V/f oscillation suppression gain 1	0~3000	38	△

Parameter	Designation	Scope	Factory default	Attr
d4-17	V/f oscillation suppression gain 2	0~3000	0	△
d4-18	Voltage setting on V/f separated pattern	0: d1-19 digital setting 1: Set by AI1 2: Set by AI2 3: Set by EAI 4: Process PID output 5: AI1 + process PID output	0	△
d4-19	Digital voltage setting on V/f separation pattern	0.0%~100.0%	0.0%	△
d4-20	Voltage variation time on V/f separated pattern	0.00s~600.00s	0.01s	△
Group d5 Vector Control Parameters of Motor 2				
d5-00	Reserved	Reserved	Reserve	×
d5-01	ASR Hi-speed proportional gain Kp1	0.0~20.0	2.0	△
d5-02	ASR Hi-speed integration time Ti1	0.000s~8.000s	0.200	△
d5-03	ASR low-speed proportional gain Kp2	0.0~20.0	2.0	△
d5-04	ASR low-speed integration time Ti2	0.000s~8.000s	0.200	△
d5-05	ASR switching FREQ 1	0.00Hz~d5-06	5.00Hz	△
d5-06	ASR switching FREQ 2	D5-05~upper limit FREQ	10.00Hz	△
d5-07	ASR input filtering time	0.0ms~500.0ms	5.0ms	△
d5-08	ASR output filtering time	0.0ms~500.0ms	0.3ms	△
d5-09	ACR proportion coeff Kp	0.000~4.000	1.000	△
d5-10	ACR integration coeff Ki	0.000~4.000	1.000	△
d5-11	Pre-excitation time	0.000s~5.000s	0.200s	△
d5-12	Driven torque restriction source	0: d5-14 digital setting 1: AI1 2: AI2 3: EAI (on IO option) 4: X6/DI pulse input 5: Communication	0	×
d5-13	Braking torque restriction source	0: d5-15 digital setting 1: AI1 2: AI2 3: EAI (on IO option) 4: X6/DI pulse input 5: Communication	0	×

Parameter	Designation	Scope	Factory default	Attr
d5-14	Digital setting of driven torque limit value	0.0%~200.0%	180.0%	△
d5-15	Digital setting of braking torque limit value	0.0%~200.0%	180.0%	△
d5-16	Flux weakening torque limit coeff	0.0%~100.0%	50.0%	△
d5-17	Driven slip compensation gain	10.0%~300.0%	100.0%	△
d5-18	Brake slip compensation gain	10.0%~300.0%	100.0%	△
Group E Enhanced Function and Protection Parameters				
Group E0 Enhanced Function				
E0-00	Switching FREQ	≤15kW: 0.7kHz~16.0kHz, factory default: 8.0 kHz 18.5kW~45kW: 0.7kHz~10.0kHz, factory default: 4.0 kHz 55kW~75kW: 0.7kHz~16.0kHz, factory default: 3.0 kHz ≥90kW: 0.7kHz~3.0kHz, factory default: 2.0 kHz	Model dependent	△
E0-01	PWM optimization	Ones place: switching FREQ relation with temperature 0: Self-adaption 1: No adaption Tens place: PWM modulation mode 0: Five-segment and seven-segment self-switchover 1: Five-segment mode 2: Seven-segment mode Hundreds place: over-modulation adaption 0: Disabled 1: Enabled Thousands place: PWM switching FREQ relation with output frequency 0: Self-adaption 1: No adaption	0100	×

Parameter	Designation	Scope	Factory default	Attr
E0-02	Action when run time attained	Ones place: action when consecutive run time attained: 0: Run continued 1: Stop and fault reported Tens place: action when accumulative run time attained: 0: Run continued 1: Stop and fault reported Hundreds place: unit of run time 0: Second 1: Hour	000	×
E0-03	Consecutive run time setting	0.0s(h)~6000.0s(h)	00s(h)	×
E0-04	Accumulative run time setting	0.0s(h)~6000.0s(h)	00s(h)	×
E0-05	Mechanical brake control	0: Disabled 1: Enabled	0	×
E0-06	Mechanical brake open frequency	0.00Hz~10.00Hz	2.50Hz	×
E0-07	Mechanical brake open current	0.0%~200.0%	120.0%	×
E0-08	Accel delay time after brake open	0.0s~10.0s	1.0s	×
E0-09	Mechanical brake FREQ	0.00Hz~10.00Hz	2.00Hz	×
E0-10	Mechanical brake close waiting time	0.0s~10.0s	0.0s	×
E0-11	Mechanical brake close holding time	0.0s~10.0s	1.0s	×
Group E1 Protection Parameters				
E1-00	Overvoltage stall	0: Invalid in all process 1: Valid in all process 2: Valid only for decelerating	1	×
E1-01	Overvoltage stall protection voltage	120%~150%	130%	×
E1-02	Undervoltage stall	0: Disabled 1: Enabled	0	×

Parameter	Designation	Scope	Factory default	Attr
E1-03	Overload alarm	Ones place: detection option: 0: Always detect 1: Detect at constant speed only Tens place: compared with: 0: Motor rated current 1: Drive rated current Hundreds place: drive action 0: Alarm but run continued 1: Alarm and coast to stop	000	×
E1-04	Overload alarm threshold	20.0%~200.0%	130.0%	△
E1-05	Overload alarm activation time	0.1s~60.0s	5.0s	△
E1-06	Protection action 1	Ones place: reserved Tens place: action at IGBT temperature measurement circuit fault (OH3): 0: Coast to stop 1: Alarm but run continued Hundreds place: abnormal EEPROM (EPr) : 0: Coast to stop 1: Alarm but run continued Thousands place: abnormal terminal communication (TrC): 0: Coast to stop 1: Alarm but run continued	0000	×

Parameter	Designation	Scope	Factory default	Attr
E1-07	Protection action 2	Ones place: abnormal power supply when running (SUE): 0: Coast to stop 1: Alarm but run continued Tens place: current detection circuit failed (CtC) 0: Coast to stop 1: Alarm but run continued Hundreds place: abnormal contactor (CCL): 0: Coast to stop 1: Alarm but run continued Thousands place: input supply fault /output phase loss (ISF, oPL): 0: Protection for neither input supply fault nor output phase loss 1: No protection for input supply fault, protection enabled for output phase loss 2: Protection enabled for input supply fault, no protection for output phase loss 3: Protection enabled both for input supply fault and output phase loss	3001	×
E1-08	Fault memory after power loss	0: Not memorized after power loss 1: Memorized after power loss	0	×
E1-09	Fault auto-reset times	0~20	0	×
E1-10	Auto-reset interval	2.0s~20.0s	2.0s	×
E1-11	Relay action on drive fault	Ones place: when undervoltage fault occurs 0: No action 1: Action enabled Tens place: when fault locked 0: No action 1: Action enabled Hundreds place: at interval of auto-reset 0: No action 1: Action enabled	010	×
E1-12	Cooling fan control	0: Auto run 1: Always run after power up	0	△

Parameter	Designation	Scope	Factory default	Attr
E1-13	Drive overheat alarm threshold	0.0°C~100.0°C	80.0°C	△
Group F Application				
Group F0 Process PID				
F0-00	PID setting	0: F0-01 digital setting 1: AI1 2: AI2 3: EAI (on IO option) 4: X6/DI pulse input 5: Communication	0	×
F0-01	PID digital setting	0.0%~100.0%	50.0%	△
F0-02	PID feedback	0: AI1 1: AI2 2: EAI (on IO option) 3: AI1+AI2 4: AI1-AI2 5: Max {AI1, AI2} 6: Min {AI1, AI2} 7: X6/DI pulse input 8: Communication	0	×
F0-03	PID adjustment	Ones place: output FREQ 0: Must be the same direction as the set run direction 1: Opposite direction allowed Tens place: integration selection 0: Integral continued when FREQ attains upper/lower limit 1: Integral stopped when FREQ attains upper/lower limit	11	×
F0-04	PID positive and negative adjustment	0: Positive adjustment 1: Negative adjustment	0	×
F0-05	Filtering time of PID setting	0.00s~60.00s	0.00s	△
F0-06	Filtering time of PID feedback	0.00s~60.00s	0.00s	△
F0-07	Filtering time of PID output	0.00s~60.00s	0.00s	△
F0-08	Proportional gain Kp1	0.0~200.0	50.0	△
F0-09	Integration time Ti1	0.000s~50.000s	0.500s	△
F0-10	Derivative time Td1	0.000s~50.000s	0.000s	△
F0-11	Proportional gain Kp2	0.0~200.0	50.0	△
F0-12	Integration time Ti2	0.000s~50.000s	0.500s	△
F0-13	Derivative time Td2	0.000s~50.000s	0.000s	△

Parameter	Designation	Scope	Factory default	Attr
F0-14	PID parameter switch	0: No switch, determined by parameters Kp1, Ti1 and Td1 1: Auto-switched on the basis of input offset 2: Switched by terminal	0	×
F0-15	Input offset under PID auto-switch	0.0%~100.0%	20.0%	△
F0-16	Sampling period T	0.001s~50.000s	0.002s	△
F0-17	PID offset limit	0.0%~100.0%	0.0%	△
F0-18	PID derivative limit	0.0%~100.0%	0.5%	△
F0-19	PID initial value	0.0%~100.0%	0.0%	×
F0-20	PID initial value holding time	0.0s~3600.0s	0.0s	△
F0-21	PID feedback loss detection value	0.0%~100.0%	0.0%	△
F0-22	PID feedback loss detection time	0.0s~30.0s	1.0s	△
F0-23	Cutoff FREQ when opposite to rotary set direction	0.00Hz~maximum FREQ	50.00Hz	△
F0-24	PID computation option	0: No computation in stop status 1: Computation continued in stop status	0	△
Group F1 Multi-step frequency				
F1-00	FREQ set source of multi-step 0	0: Digital setting F1-02 1: Digital setting b0-02 + control panel \wedge/\vee adjustment 2: Digital setting b0-02 + terminal UP/DOWN adjustment 3: AI1 4: AI2 5: EAI (on IO option) 6: X6/DI pulse input 7: Process PID output 8: Communication	0	×
F1-01	FREQ set source of multi-step 1	0: Digital setting F1-03 1: Digital setting b0-04 + control panel \wedge/\vee adjustment 2: Digital setting b0-04 + terminal UP/DOWN 3: AI1 4: AI2 5: EAI (on IO option)	0	×

Parameter	Designation	Scope	Factory default	Attr
		6: X6/DI pulse input 7: Process PID output 8: Communication		
F1-02	Multi-step FREQ 0	-100.0%~100.0% Note: percentage against upper limit FREQ b0-09. Meaning of F1-03~F1-17 is the same with F1-02	0.0%	△
F1-03	Multi-step FREQ 1	-100.0%~100.0%	0.0%	△
F1-04	Multi-step FREQ 2	-100.0%~100.0%	0.0%	△
F1-05	Multi-step FREQ 3	-100.0%~100.0%	0.0%	△
F1-06	Multi-step FREQ 4	-100.0%~100.0%	0.0%	△
F1-07	Multi-step FREQ 5	-100.0%~100.0%	0.0%	△
F1-08	Multi-step FREQ 6	-100.0%~100.0%	0.0%	△
F1-09	Multi-step FREQ 7	-100.0%~100.0%	0.0%	△
F1-10	Multi-step FREQ 8	-100.0%~100.0%	0.0%	△
F1-11	Multi-step FREQ 9	-100.0%~100.0%	0.0%	△
F1-12	Multi-step FREQ 10	-100.0%~100.0%	0.0%	△
F1-13	Multi-step FREQ 11	-100.0%~100.0%	0.0%	△
F1-14	Multi-step FREQ 12	-100.0%~100.0%	0.0%	△
F1-15	Multi-step FREQ 13	-100.0%~100.0%	0.0%	△
F1-16	Multi-step FREQ 14	-100.0%~100.0%	0.0%	△
F1-17	Multi-step FREQ 15	-100.0%~100.0%	0.0%	△

Parameter	Designation	Scope	Factory default	Attr
Group F2 Simple PLC				
F2-00	Simple PLC run mode	Ones place: PLC run mode 0: Stop after a single cycle 1: Continue to run in the last FREQ after a single cycle 2: Cycle repeated Tens place: power loss memory 0: No memory on power loss 1: Memorized on power loss Hundreds place: starting mode 0: Run from the first step "multi-step frequency 0" 1: Continue to run from the step of stop (or fault) 2: Continue to run from the step and FREQ at which run stopped (or fault occurred) Thousands place: unit of simple PLC run time 0: Second (s) 1: Minute (min)	0000	×
F2-01	Setting of multi-step 0	Ones place: FREQ setting 0: Multi-step FREQ 0 (F1-02) 1: AI1 2: AI2 3: EAI (on IO option) 4: X6/DI pulse input 5: Process PID output 6: Multi-step FREQ 7: Communication Tens place: run direction 0: Forward 1: Reverse 2: Determined by run command Hundreds place: Accel/Decel time 0: Accel/Decel time 1 1: Accel/Decel time 2 2: Accel/Decel time 3 3: Accel/Decel time 4	000	×
F2-02	Run time of step 0	0.0s(min)~6000.0s(min)	0.0s	△

Parameter	Designation	Scope	Factory default	Attr
F2-03	Setting of step 1	Ones place: FREQ setting 0: Multi-step FREQ 1 (F1-03) 1~7: Same as F2-01 Tens place: run direction (same as F2-01) Hundreds place: Accel/Decel time option (same as F2-01)	000	×
F2-04	Run time of step 1	0.0s(min)~6000.0s(min)	0.0s	△
F2-05	Setting of step 2	Ones place: FREQ setting 0: Multi-step FREQ 2 (F1-04) 1~7: Same as F2-01 Tens place: run direction (same as F2-01) Hundreds place: Accel/Decel time option (same as F2-01)	000	×
F2-06	Run time of step 2	0.0s(min)~6000.0s(min)	0.0s	△
F2-07	Setting of step 3	Ones place: FREQ setting 0: Multi-step FREQ 3 (F1-05) 1~7: Same as F2-01 Tens place: run direction (same as F2-01) Hundreds place: Accel/Decel time option (same as F2-01)	000	×
F2-08	Run time of step 3	0.0s(min)~6000.0s(min)	0.0s	△
F2-09	Setting of step 4	Ones place: FREQ setting 0: Multi-step FREQ 4 (F1-06) 1~7: Same as F2-01 Tens place: run direction (same as F2-01) Hundreds place: Accel/Decel time option (same as F2-01)	000	×
F2-10	Run time of step 4	0.0s(min)~6000.0s(min)	0.0s	△
F2-11	Setting of step 5	Ones place: FREQ setting 0: Multi-step FREQ 5 (F1-07) 1~7: Same as F2-01 Tens place: run direction (same as F2-01) Hundreds place: Accel/Decel time option (same as F2-01)	000	×
F2-12	Run time of step 5	0.0s(min)~6000.0s(min)	0.0s	△
F2-13	Setting of step 6	Ones place: FREQ setting 0: Multi-step FREQ 6 (F1-08)	000	×

Parameter	Designation	Scope	Factory default	Attr
		1~7: Same as F2-01 Tens place: run direction (same as F2-01) Hundreds place: Accel/Decel time option (same as F2-01)		
F2-14	Run time of step 6	0.0s(min)~6000.0s(min)	0.0s	△
F2-15	Setting of step 7	Ones place: FREQ setting 0: Multi-step FREQ 7 (F1-09) 1~7: Same as F2-01 Tens place: run direction (same as F2-01) Hundreds place: Accel/Decel time option (same as F2-01)	000	×
F2-16	Run time of step 7	0.0s(min)~6000.0s(min)	0.0s	△
F2-17	Setting of step 8	Ones place: FREQ setting 0: Multi-step FREQ 8 (F1-10) 1~7: Same as F2-01 Tens place: run direction (same as F2-01) Hundreds place: Accel/Decel time option (same as F2-01)	000	×
F2-18	Run time of step 8	0.0s(min)~6000.0s(min)	0.0s	△
F2-19	Setting of step 9	Ones place: FREQ setting 0: Multi-step FREQ 9 (F1-11) 1~7: Same as F2-01 Tens place: run direction (same as F2-01) Hundreds place: ACC/DEC time option (same as F2-01)	000	×
F2-20	Run time of step 9	0.0s(min)~6000.0s(min)	0.0s	△
F2-21	Setting of step 10	Ones place: FREQ setting 0: multi-step FREQ 10 (F1-12) 1~7: same as F2-01 Tens place: run direction (same as F2-01) Hundreds place: Accel/Decel time option (same as F2-01)	000	×
F2-22	Run time of step 10	0.0s(min)~6000.0s(min)	0.0s	△
F2-23	Setting of step 11	Ones place: FREQ setting 0: Multi-step FREQ 11 (F1-13) 1~7: Same as F2-01 Tens place: run direction (same as	000	×

Parameter	Designation	Scope	Factory default	Attr
		F2-01) Hundreds place: Accel/Decel time option (same as F2-01)		
F2-24	Run time of step 11	0.0s(min)~6000.0s(min)	0.0s	△
F2-25	Setting of step 12	Ones place: FREQ setting 0: Multi-step FREQ 12 (F1-14) 1~7: Same as F2-01 Tens place: run direction (same as F2-01) Hundreds place: Accel/Decel time option (same as F2-01)	000	×
F2-26	Run time of step 12	0.0s(min)~6000.0s(min)	0.0s	△
F2-27	Setting of step 13	Ones place: FREQ setting 0: Multi-step FREQ 13 (F1-15) 1~7: Same as F2-01 Tens place: run direction (same as F2-01) Hundreds place: Accel/Decel time option (same as F2-01)	000	×
F2-28	Run time of step 13	0.0s(min)~6000.0s(min)	0.0s	△
F2-29	Setting of step 14	Ones place: FREQ setting 0: Multi-step FREQ 14 (F1-16) 1~7: Same as F2-01 Tens place: run direction (same as F2-01) Hundreds place: Accel/Decel time option (same as F2-01)	000	×
F2-30	Run time of step 14	0.0s(min)~6000.0s(min)	0.0s	△
F2-31	Setting of step 15	Ones place: FREQ setting 0: Multi-step FREQ 15 (F1-17) 1~7: Same as F2-01 Tens place: run direction (same as F2-01) Hundreds place: Accel/Decel time option (same as F2-01)	000	×
F2-32	Run time of step 15	0.0s(min)~6000.0s(min)	0.0s	△
Group F3 Wobble Frequency and Fixed Length Count				
F3-00	Wobble FREQ function setting	0: Wobble FREQ function disabled 1: Wobble FREQ function enabled	0	×
F3-01	Wobble FREQ run setting	Ones place: started method 0: Automatically 1: Started by terminal	0000	×

Parameter	Designation	Scope	Factory default	Attr
		Tens place: amplitude control 0: Relative to center FREQ 1: Relative to maximum FREQ Hundreds place: wobble FREQ memorized when stop 0: Memory enabled 1: Memory disabled Thousands place: wobble FREQ memorized on power loss 0: Memory enabled 1: Memory disabled		
F3-02	Pre-wobble FREQ	0.00Hz~600.00Hz	0.00Hz	△
F3-03	Pre-wobble FREQ holding time	0.0s~3600.0s	0.0s	△
F3-04	Wobble FREQ amplitude	0.0%~50.0%	0.0%	△
F3-05	Hop FREQ	0.0%~50.0% (relative to F3-04)	0.0%	△
F3-06	Cycle of wobble FREQ	0.1s~999.9s	0.0s	△
F3-07	Triangular wave ramp-up time	0.0%~100.0% (of wobble FREQ cycle)	0.0%	△
F3-08	Length unit	0: m 1: 10m	0	△
F3-09	Length setting	0~65535	1000	△
F3-10	Pulse number per meter	0.1~6553.5	100.0	△
F3-11	Action when the length attained	0: Not stop 1: Stop	0	△
F3-12	Set count value	1~65535	1000	△
F3-13	Designated count value	1~65535	1000	△
Group F5 Vector control without PG for synchronous motor				
F5-00	Recognition of rotor initial magnetic pole position	0~2 0: Detecting forbidden 1: Recongnition of pulse injection initial position 2: Reserved	0	△
F5-04	Initial pull-in current	0%~200.0%	50.0%	△
F5-05	Cut-off FREQ of pull-in current	0~b0-09	0.00Hz	△
F5-09	Max. torque current ratio coefficient	0: forbid MTPA control Not 0: MTPA coefficient Note: generally 0, no need to modify	0.000	△
F5-12	Speed observer bandwidth coefficient	0.000~32.000	4.000	△

Parameter	Designation	Scope	Factory default	Attr
F5-13	Speed observer filter coeff.	0.000~32.000	0.200	△
F5-17	Open-loop vector mode selection	0000~1111 Ones: dead-time compensating enabled Tens: feedforward control enabled Hundreds: start step-out self-recovery enabled Thousands: speed loop integral separating enabled	0011	△
F5-20	Max. flux weakening current allowed	-8000~8000	-6000	△
F5-21	Max voltage utilization ratio	0~65535	31767	△
F5-24	Flux weakening loop proportional gain	0~65535	0	△
F5-25	Flux weakening loop integral gain	0~65535	800	△
Group H Communication Parameters				
Group H0 MODBUS Communication Parameters				
H0-00	SCI port selection	0: Local 485 port 1: Optional 232 port	0	×
H0-01	SCI port communication configuration	Ones place: baud rate 0: 4800bps 1: 9600bps 2: 19200bps 3: 38400bps 4: 57600bps 5: 115200bps Tens place: data format 0: 1-8-2-N format, RTU 1: 1-8-1-E format, RTU 2: 1-8-1-O Format, RTU 3: 1-7-2-N format, ASCII 4: 1-7-1-E format, ASCII 5: 1-7-1-O format, ASCII Hundreds place: connection type 0: Direct cable connection (232/485) 1: MODEM (232) Thousands place: communication data handling at power loss 0: Saved at power loss 1: Not saved at power loss	0001	×

Parameter	Designation	Scope	Factory default	Attr
H0-02	Local address of SCI port communication	0~247, 0 is broadcast address	5	×
H0-03	Time out detection of SCI port communication	0.0s~1000.0s	0.0s	×
H0-04	Time delay of SCI port communication	0ms~1000ms	0ms	×
H0-05	Master/Slave option	0: PC controls this drive 1: As master 2: As slave	0	×
H0-06	Parameter store address when this drive working as master	0:b0-02 1:F0-01	0	×
H0-07	Proportional factor of received FREQ	0.0~1000.0%	100.0%	△
Group H1 Profibus-DP Communication Parameters				
H1-00	Local address	1~126; 127 is broadcast address	4	△
H1-01	PPO type	0: Profibus disabled 1: PPO1 2: PPO2 3: PPO3 4: PPO4 5: PPO5	0	△
H1-02	PZD2_OUT(the master → the slave)	0: none 0x6200~0x6214	0	△
H1-03	PZD3_OUT(the master → the slave)	0: none 0x6200~0x6214	0	△
H1-04	PZD4_OUT(the master → the slave)	0: none 0x6200~0x6214	0	△
H1-05	PZD5_OUT(the master → the slave)	0: none 0x6200~0x6214	0	△
H1-06	PZD6_OUT(the master → the slave)	0: none 0x6200~0x6214	0	△
H1-07	PZD7_OUT(the master → the slave)	0: none 0x6200~0x6214	0	△
H1-08	PZD8_OUT(the master → the slave)	0: none 0x6200~0x6214	0	△

Parameter	Designation	Scope	Factory default	Attr
H1-09	PZD9_OUT(the master → the passive)	0: none 0x6200~0x6214	0	△
H1-10	PZD10_OUT(the master → the slave)	0: none 0x6200~0x6214	0	△
H1-11	PZD2_IN(the slave → the master)	0: none A0-00~U2-xx 0x6200~0x6214; 0x6300~0x6323	0	△
H1-12	PZD3_IN(the slave → the master)	0: none A0-00~U2-xx; 0x6200~0x6214; 0x6300~0x6323	0	△
H1-13	PZD4_IN(the slave → the master)	0: none A0-00~U2-xx 0x6200~0x6214; 0x6300~0x6323	0	△
H1-14	PZD5_IN(the slave → the master)	0: none A0-00~U2-xx 0x6200~0x6214; 0x6300~0x6323	0	△
H1-15	PZD6_IN(the slave → the master)	0: none A0-00~U2-xx 0x6200~0x6214; 0x6300~0x6323	0	△
H1-16	PZD7_IN(the slave → the master)	0: none A0-00~U2-xx 0x6200~0x6214; 0x6300~0x6323	0	△
H1-17	PZD8_IN(the slave → the master)	0: none A0-00~U2-xx 0x6200~0x6214; 0x6300~0x6323	0	△
H1-18	PZD9_IN(the slave → the master)	0: none A0-00~U2-xx 0x6200~0x6214; 0x6300~0x6323	0	△
H1-19	PZD10_IN(the slave → the master)	0: none A0-00~U2-xx 0x6200~0x6214; 0x6300~0x6323	0	△
H1-20	Operation at bus fault	0: No action 1: Stop	0	△

Parameter	Designation	Scope	Factory default	Attr
Group L Keys and Display of Control panel				
Group L0 Keys of Control panel				
L0-00	MF key setting	0: No function 1: Forward jog 2: Reverse jog 3: Forward/reverse switchover 4: Emergency stop 1 (set Decel time by b2-09) 5: Emergency stop 2 (coast to stop) 6: Run command sources shifted	0	△
L0-01	Keys locked option	0: Not locked 1: All locked 2: Keys locked except RUN, STOP/RESET 3: Keys locked except STOP/RESET 4: Keys locked other than >>	0	△
L0-02	Function of STOP key	0: STOP key active only at control panel control 1: STOP key deactivated under any command source	0	△
L0-03	FREQ adjustment through keys \wedge/\vee	Ones place: option at stop 0: Clear at stop 1: Holding at stop Tens place: option at power loss 0: Clear at power loss 1: Holding at power loss Hundreds place: integrating option 0: Integrating disabled 1: Integrating enabled Thousands place: run direction 0: Direction changing prohibited 1: Direction changing permitted	0100	△
L0-04	Step size of FREQ adjustment through keys \wedge/\vee	0.00Hz/s~10.00Hz/s	0.03 Hz/s	△
Group L1 Control Panel Display Setting				
L1-00	Display parameter setting 1 on run status	Binary system setting: 0: No display 1: Display Ones place: BIT0: Run FREQ (Hz) BIT1: Set FREQ (Hz)		△

Parameter	Designation	Scope	Factory default	Attr
		BIT2: Bus voltage (V) BIT3: Output current (A) Tens place: BIT0: Output torque (%) BIT1: Output power (kW) BIT2: Output voltage (V) BIT3: Motor speed (r/min) Hundreds place: BIT0: AI1 (V) BIT1: AI2 (V) BIT2: EAI (V) BIT3: Output sync FREQ (Hz) Thousands place: BIT0: DI BIT1: External count value BIT2: Reserved BIT3: Reserved Note: when this parameter value is set to 0000, run FREQ (Hz) would be displayed as default	080F	
L1-01	Display parameter setting 2 on run status	Binary system setting: 0: No display 1: Display Ones place: BIT0: Run linear speed (m/s) BIT1: Set linear speed (m/s) BIT2: Input terminal status BIT3: Output terminal status Tens place: BIT0: PID setting (%) BIT1: PID feedback (%) BIT2: Set length (m) BIT3: Actual length (m) Hundreds place: reserved Thousands place: reserved	0000	△
L1-02	Display parameter setting on stop status	Binary system setting: 0: No display 1: Display Ones place: BIT0: FREQ setting (Hz) BIT1: Bus voltage (V) BIT2: Input terminal status	0003	△

Parameter	Designation	Scope	Factory default	Attr
		BIT3: Output terminal status Tens place: BIT0: AI1 (V) BIT1: AI2 (V) BIT2: EAI (V) BIT3: Reserved Hundreds place: BIT0: PID setting (%) BIT1: PID feedback (%) BIT2: Set length (m) BIT3: Actual length (m) Thousands place: BIT0: Run linear speed (m/s) BIT1: Set linear speed (m/s) BIT2: External count value BIT3: DI Note: when this parameter value is set to 0000, the set FREQ would be displayed as default (Hz)		
L1-03	Linear speed COEFF	0.1%~999.9%	100.0%	△
Group U Monitoring				
Group U0 Status Monitoring				
U0-00	Run FREQ	0.00Hz~600.00Hz	0.00Hz	◎
U0-01	Set FREQ	0.00Hz~600.00Hz	0.00Hz	◎
U0-02	Bus voltage	0V~65535V	0V	◎
U0-03	Output voltage	0V~65535V	0V	◎
U0-04	Output current	0.0A~6553.5A	0.0A	◎
U0-05	Output torque	-300.0%~300.0%	0.0%	◎
U0-06	Output power	0.0%~300.0%	0.0%	◎
U0-07	Master FREQ set source	0: Digital setting + adjustment through ^/∇ on control panel 1: Digital setting + terminal UP/DOWN adjustment 2: Analog input AI1 3: Analog input AI2 4: Analog input EAI 5: X6/DI pulse input 6: Process PID output 7: PLC 8: Multi-step FREQ 9: Communication	0	◎

Parameter	Designation	Scope	Factory default	Attr
U0-08	Auxiliary FREQ set source	0: No set 1: Digital setting + adjustment through \wedge/\vee on control panel 2: Digital setting + terminal UP/DOWN adjustment 3: Analog input AI1 4: Analog input AI2 5: Analog input EAI 6: X6/DI pulse input 7: Process PID output 8: PLC 9: Multi-step FREQ 10: Communication	0	◎
U0-09	Master FREQ setting	0.00Hz~600.00Hz	0.00Hz	◎
U0-10	Auxiliary FREQ setting	0.00Hz~600.00Hz	0.00Hz	◎
U0-11	Drive status	Ones place: run status 0: Accelerating 1: Decelerating 2: Constant speed run Tens place: drive status 0: Stop 1: Running 2: Autotuning	00	◎
U0-12	AI1 input voltage	0.00V~10.00V	0.00V	◎
U0-13	AI2 input voltage	-10.00V~10.00V	0.00V	◎
U0-14	EAI input voltage	0.00V~10.00V	0.00V	◎
U0-15	AO1 output	0.0%~100.0%	0.0%	◎
U0-16	EAO output	0.0%~100.0%	0.0%	◎
U0-17	X6/DI HF pulse FREQ	0.0kHz~50.0kHz	0.0kHz	◎
U0-18	Digital input terminal status	00~7F	00	◎
U0-19	Digital output terminal status	0~7	0	◎
U0-20	PID set	0.0%~100.0%	0.0%	◎
U0-21	PID feedback	0.0%~100.0%	0.0%	◎
U0-22	PID input offset	-100.0%~100.0%	0.0%	◎
U0-23	PLC step	0~15	0	◎
U0-24	V/f separated target voltage	0.0%~100.0%	0.0%	◎
U0-25	V/f separated actual output voltage	0.0%~100.0%	0.0%	◎
U0-26	Reserved	Reserved	Reserved	◎
U0-27	Reserved	Reserved	Reserved	◎

Parameter	Designation	Scope	Factory default	Attr
U0-28	Reserved	Reserved	Reserved	⊙
U0-29	Reserved	Reserved	Reserved	⊙
U0-30	Cumulative power-up time	0h~65535h	0h	⊙
U0-31	Cumulative run time	0h~65535h	0h	⊙
U0-32	Heat sink temperature 1	-40.0°C~100.0°C	0.0°C	⊙
U0-33	Heat sink temperature 2	-40.0°C~100.0°C	0.0°C	⊙
U0-34	FAL fault source	0: No fault 1: IGBT overcurrent 2: Reserved 3: Output grounding fault 4: Output overcurrent 5: DC bus overvoltage 6: Other sources	0	⊙
U0-35	Terminal count value	0~65535	0	⊙
U0-36	Run command log at LoU	0~1	0	⊙
U0-37	Fault code log at LoU	0~100	0	⊙
U0-38	Reserved	Reserved	Reserved	⊙
U0-39	CtC fault source	0: No fault 1: U-phase current detection circuit fault 2: V-phase current detection circuit fault 3: W-phase current detection circuit fault	0	⊙
U0-40	Higher-bit numbers of actual length	0~65	0	⊙
U0-41	Lower-bit numbers of actual length	0~65535	0	⊙
U0-42	Higher-bit numbers of control panel \wedge/\vee stored value	-1~1	0	⊙
U0-43	Lower-bit numbers of control panel \wedge/\vee stored value	0.00~655.35 Hz	0.00Hz	⊙
U0-44	Higher-bit numbers of terminal UP/DOWN stored value	-1~1	0	⊙
U0-45	Lower-bit numbers of terminal UP/DOWN stored value	0.00~655.35 Hz	0.00Hz	⊙
U0-46	Reserved	Reserved	Reserved	⊙
U0-47	Reserved	Reserved	Reserved	⊙

Parameter	Designation	Scope	Factory default	Attr
U0-48	Reserved	Reserved	Reserved	⊙
U0-49	Reserved	Reserved	Reserved	⊙
U0-50	Reserved	Reserved	Reserved	⊙
U0-51	Reserved	Reserved	Reserved	⊙
U0-52	Center FREQ of wobble FREQ	0~600.00 Hz	0.00 Hz	⊙
U0-53	Initial position angle	0.0~6000.0	0.0	⊙
U0-54	Reserved	Reserved	Reserved	⊙
U0-55	Reserved	Reserved	Reserved	⊙
Group U1 History Fault				
U1-00	History fault 1 (latest)	0: No fault 1: Accel overcurrent (oC1) 2: Constant-speed overcurrent (oC2) 3: Decel overcurrent (oC3) 4: Accel overvoltage (ov1) 5: Constant-speed overvoltage (ov2) 6: Decel overvoltage (ov3) 7: Module protection (FAL) 8: Autotuning failed (tUN) 9: Drive overloaded (oL1) 10: Motor overloaded (oL2) 11: Current detection abnormal (CtC) 12: Ground short-circuit protection at output side (GdP) 13: Input power supply fault (ISF) 14: Phase loss at output side (oPL) 15: Inverter module overloaded (oL3) 16: Module overheated (oH1) 17: Motor overheated (PTC) (oH2) 18: Module temperature detection disconnection (oH3) 19: Reserved 20: Abnormal option board connection (EC1) 21: Reserved 22: Control board flat cable connection abnormal (dLC) 23: Analog terminal functional mutex (TEr) 24: External equipment malfunction (PEr) 25: Reserved	0	⊙

Parameter	Designation	Scope	Factory default	Attr
		26: Continuous run time attained (to2) 27: Accumulative run time attained (to3) 28: Power supply abnormal in running (SUE) 29: EEPROM read/write fault (EPr) 30: Contactor close fault (CCL) 31: Port communication abnormal (TrC) 32: Control panel communication abnormal (PdC) 33: Parameter copy fault (CPy) 34: Reserved 35: Software version compatibility fault (SFt) 36: CPU interference as a fault (CPU) 37: Overcurrent reference fault (oCr) 38: 5V power supply out-of-limit (SP1) 39: 10V power supply out-of-limit (SP1) 40: AI input out-of-limit (AIP) 41: Undervoltage protection (LoU) 42-44: Reserved 45: PID feedback loss (PIo) 46: Profibus communication abnormal (PFS) 47: Syn. motor back EMF abnormal (bEF)		
U1-01	Run frequency at fault 1	0.00Hz~600.00Hz	0.00Hz	◎
U1-02	Output current at fault 1	0.0A~6553.5A	0.0A	◎
U1-03	Bus voltage at fault 1	0V~10000V	0V	◎
U1-04	Temperature 1 of heat sink at fault 1	-40.0℃~100.0℃	0.0℃	◎
U1-05	Temperature 2 of heat sink at fault 1	-40.0℃~100.0℃	0.0℃	◎
U1-06	Input terminal status at fault 1	0~FFFF	0000	◎
U1-07	Output terminal status at fault 1	0~FFFF	0000	◎
U1-08	Cumulative run time at fault 1	0h~65535h	0h	◎

Parameter	Designation	Scope	Factory default	Attr
U1-09	Code of fault 2	Same as U1-00	0	◎
U1-10	Run frequency at fault 2	0.00Hz~600.00Hz	0.00Hz	◎
U1-11	Output current at fault 2	0.0A~6553.5A	0.0A	◎
U1-12	Bus voltage at fault 2	0V~10000V	0V	◎
U1-13	Temperature 1 of heat sink at fault 2	-40.0°C~100.0°C	0.0°C	◎
U1-14	Temperature 2 of heat sink at fault 2	-40.0°C~100.0°C	0.0°C	◎
U1-15	Input terminal status at fault 2	0~FFFF	0000	◎
U1-16	Output terminal status at fault 2	0~FFFF	0000	◎
U1-17	Cumulative run time at fault 2	0h~65535h	0h	◎
U1-18	Code of fault 3	Same as U1-00	0	◎
U1-19	Run frequency at fault 3	0.00Hz~600.00Hz	0.00Hz	◎
U1-20	Output current at fault 3	0.0A~6553.5A	0.0A	◎
U1-21	Bus voltage at fault 3	0V~1000V	0V	◎
U1-22	Temperature 1 of heat sink at fault 3	-40.0°C~100.0°C	0.0°C	◎
U1-23	Temperature 2 of heat sink at fault 3	-40.0°C~100.0°C	0.0°C	◎
U1-24	Input terminal status at fault 3	0~FFFF	0000	◎
U1-25	Output terminal status at fault 3	0~FFFF	0000	◎
U1-26	Cumulative run time at fault 3	0h~65535h	0h	◎

Chapter 6 Specification of Parameters

Group A System Parameters and Parameter Management

Group A0 System Parameters

A0-00	Setting of user password	Range: 0~FFFF	Factory default: 0000
-------	--------------------------	---------------	--------------------------

Setting of password:

A non-zero four-digital number could be set as a user password by entering this password into A0-00 and pressing ENT key to confirm once, then reenter and reconfirm it once again within 10 seconds. Once this password has been successfully set, the word "P-SET" would be displayed. The password setting will take effect as long as there is no operation on control panel within 5 minutes, or cutting the power off and power up again.

Change password:

Access A0-00 after entering the original four-digit password (at this point, A0-00 displays 0000) and set the new password following the above-noted procedure.

Password clearance:

Access A0-00 after entering the original four-digit password (at this point, A0-00 displays 0000), enter 0000 twice and press ENT key to make confirmation. In this way, password is successfully cleared and the word "P-CLR" is displayed.

A0-01	Parameter display	Range: 0~3	Factory default: 0
-------	-------------------	------------	-----------------------

This parameter sets the display/hide of parameters.

- 0: Display all parameters (A1-20~A1-21 parameter display/hide is valid)
- 1: Only display A0-00 and A0-01
- 2: Only display A0-00, A0-01 and user-defined A1-00~A1-19
- 3: Only display A0-00, A0-01, and the parameters different from factory default

A0-02	Parameter protection	Range: 0~1	Factory default: 0
-------	----------------------	------------	-----------------------

- 0: All parameter programming allowed
 - 1: Only A0-00 and this parameter programming allowed
- When this parameter is set to 1, all parameters other than A0-00 and A0-02 are not allowed to modify. Set A0-02 to 0 before the modification of other parameters.

A0-03	Parameter restoration	Range: 0~4	Factory default: 0
-------	-----------------------	------------	-----------------------

0: No operation

1: Clear fault record

When this parameter is set to 1, all fault record of Group U1 will be cleared.

2: Restore all parameters to factory default (excluding motor parameters)

3: Restore all parameters to factory default (including motor parameters)

4: Restore all parameters to backup parameters

A0-04	Parameter backup	Range: 0~1	Factory default: 0
-------	------------------	------------	-----------------------

0: No operation

1: Backup all parameters

A0-05	Parameter copy	Range: 0~3	Factory default: 0
-------	----------------	------------	-----------------------

0: No operation

1: Upload all parameters other than Group U to control panel

2: Download all parameters of control panel other than d0-01~d0-18 and d3-01~d3-18 to drive

3: Download all parameters of control panel to drive

A0-06	Type of drive	Range: 0~1	Factory default: 0
-------	---------------	------------	-----------------------

0: Type G (applicable to constant-torque load)

1: Type L (applicable to light-duty load like fan or pump)

A0-07	Power supply type of SMPS	Range: 0~1	Factory default: 0
-------	---------------------------	------------	-----------------------

0: Supplied by DC bus voltage of drive main circuit

The switching power supply inside the drive is supplied by DC bus voltage.

1: Supplied independently

The switching power supply inside the drive is not supplied by DC bus voltage, while it is supplied by independent rectifier circuit or battery, and in such circumstance, option board EPC-VD2 is required for detecting the DC bus voltage of main circuit. This setting is usually for occasions that the work of drive control circuit cannot be stopped at power loss.

A0-08	Motor 1 / motor 2 selection	Range: 0~1	Factory default: 0
-------	-----------------------------	------------	-----------------------

0: Motor 1

Selects the current loaded motor as motor 1. Set the parameters of motor 1 in parameter

groups d0~d2.

1: Motor 2

Selects the current loaded motor as motor 2. Set the parameters of motor 1 in parameter groups d3~d5. The current loaded motor can also be selected through digital input terminal "motor 1/2 switchover" as shown in Table 6-1:

Table 6-1

A0-08	Motor 1/2 switchover terminal	Motor selection
0	OFF	Motor 1
0	ON	Motor 2
1	OFF	Motor 2
1	ON	Motor 1

A0-09	Motor control technique	Range: 00~33	Factory default: 00
-------	-------------------------	--------------	---------------------

◆ Ones place: motor 1 control technique

0: V/f control

Constant Volt/Hertz ratio control: Applicable to such cases in which the performance requirement to the drive is not rigorous, or using one drive to drive several motors, or it is difficult to identify motor parameters correctly, etc. When motor 1 under V/f control is selected, need to set related parameters group d1 well.

1: Sensor-less vector control 1

This helps achieve high-performance control without encoder and provides strong adaptability of load. Under this selection, please correctly set motor parameters of Group d0 and vector control parameters of Group d2. Sensor-less vector control 1 is robust vector control. If motor rotary autotuning is not able to be performed or permitted, sensor-less vector control 1 performance would be relatively ideal than sensor-less vector control 2.

2: Sensor-less vector control 2

This helps achieve high-performance control without encoder. This control technique is superior to sensor-less vector control 1. Under this selection, please correctly set motor parameters of Group d0 and vector control parameters of Group d2. Sensor-less vector control 2 is precise vector control and it requires motor rotary autotuning.

3: Synchronous motor sensor-less vector control

This helps achieve high-performance control of PMSM without encoder and provides strong adaptability of load. Under this selection, please correctly set motor parameter of Group d0, vector control parameter of Group d2 and PMSM sensor-less vector control auxiliary parameter of Group F5.

◆ Tens place: motor 2 control technique

0: V/f control

Constant Volt/Hertz ratio control: Applicable to such cases in which the performance requirement to the drive is not rigorous, or using one drive to drive several motors, or it is difficult to identify motor parameters correctly, etc. When motor 1 under V/f control is selected, need to set related parameters group d4 well.

1: sensor-less vector control 1

This helps achieve high-performance control without encoder and provides strong adaptability of load. Under this selection, please correctly set motor parameters of Group d3 and vector control parameters of Group d5. Sensor-less vector control 1 is robust vector control. If motor rotary autotuning is not able to be performed or permitted, sensor-less vector control 1 performance would be relatively ideal than sensor-less vector control 2.

2: Sensor-less vector control 2

This helps achieve high-performance control without encoder. This control technique is superior to sensor-less vector control 1. Under this selection, please correctly set motor parameters of Group d3 and vector control parameters of Group d5. Under this selection, please correctly set motor parameters of Group d0 and vector control parameters of Group d2. Sensor-less vector control 2 is precise vector control and it requires motor rotary autotuning.

3: Synchronous motor sensor-less vector control

This helps achieve high-performance control of PMSM without encoder and provides strong adaptability of load. Under this selection, please correctly set motor parameter of Group d3, vector control parameter of Group d5 and PMSM sensor-less vector control auxiliary parameter of Group F5.

 **ATTENTION:**

When vector control mode is selected, it is necessary to perform motor parameter identification in order to obtain correct motor parameters before initial running. Upon the completion of normal process of motor parameter identification, automatically acquired motor parameters will be stored into drive for control operation during running.

It should be noted when vector control is selected that one drive can only be used to drive one motor. The capacity gap between the drive and the motor should not be excessively big. Added to this, the power of motor could be two classes lower or one class higher than its matching drive. Failure to comply will be most likely to result in performance degradation or abnormal working.

Group A1 User-defined Display Parameters

A1-00	User-defined display parameter 1	Range: A0-00~U1-26	Factory default: A0-00
-------	----------------------------------	--------------------	------------------------

A1-01	User-defined display parameter 2	Range: A0-00~U1-26	Factory default: A0-00
A1-02	User-defined display parameter 3	Range: A0-00~U1-26	Factory default: A0-00
A1-03	User-defined display parameter 4	Range: A0-00~U1-26	Factory default: A0-00
A1-04	User-defined display parameter 5	Range: A0-00~U1-26	Factory default: A0-00
A1-05	User-defined display parameter 6	Range: A0-00~U1-26	Factory default: A0-00
A1-06	User-defined display parameter 7	Range: A0-00~U1-26	Factory default: A0-00
A1-07	User-defined display parameter 8	Range: A0-00~U1-26	Factory default: A0-00
A1-08	User-defined display parameter 9	Range: A0-00~U1-26	Factory default: A0-00
A1-09	User-defined display parameter 10	Range: A0-00~U1-26	Factory default: A0-00
A1-10	User-defined display parameter 11	Range: A0-00~U1-26	Factory default: A0-00
A1-11	User-defined display parameter 12	Range: A0-00~U1-26	Factory default: A0-00
A1-12	User-defined display parameter 13	Range: A0-00~U1-26	Factory default: A0-00
A1-13	User-defined display parameter 14	Range: A0-00~U1-26	Factory default: A0-00
A1-14	User-defined display parameter 15	Range: A0-00~U1-26	Factory default: A0-00
A1-15	User-defined display parameter 16	Range: A0-00~U1-26	Factory default: A0-00
A1-16	User-defined display parameter 17	Range: A0-00~U1-26	Factory default: A0-00
A1-17	User-defined display parameter 18	Range: A0-00~U1-26	Factory default: A0-00
A1-18	User-defined display parameter 19	Range: A0-00~U1-26	Factory default: A0-00
A1-19	User-defined display parameter 20	Range: A0-00~U1-26	Factory default: A0-00

A1-00~A1-19 set values would not take effect unless A0-01 is set to 2

Setting range of thousands place: A, b, C, d, E, F, H, L, U

Setting range of hundreds place: 0~9;

Setting range of tens place: 0~9;

Setting range of ones place: 0~9.

Example:

To exclusively display parameters A0-00, A0-01, b0-01, E0-01 and F0-01, it is merely necessary to set A1-00 to b0-01, A1-01 to E0-01, A1-02 to F0-01 and A1-03~A1-19 to A0-00 and then set A0-01 to 2.

A1-20	Parameter group display/hide setting 1	Range: 0000~FFFF	Factory default: FFFF
A1-21	Parameter group display/hide setting 2	Range: 0000~FFFF	Factory default: FFFF

When A0-01 is set to '0' to display all parameters, only the parameters whose bit corresponding to A1-20 and A1-21 is 1 can be displayed.

The parameters that correspond to bit 15 (the highest bit of binary system) ~ bit 0 (the lowest bit of binary system) of A1-20 are shown as table 6-2.

Table 6-2

bit15	bit14	bit13	bit12	bit11	bit10	bit9	bit8
E0	d6	d5	d4	d3	d2	d1	d0
bit7	bit6	bit5	bit4	bit3	bit2	bit1	bit0
C4	C3	C2	C1	C0	b2	b1	b0

The parameters that correspond to bit 15 (the highest bit of binary system) ~ bit 0 (the lowest bit of binary system) of A1-21 are shown as follows:

Table 6-3

bit15	bit14	bit13	bit12	bit11	bit10	bit9	bit8
U2	U1	U0	L1	L0	H2	H1	H0
bit7	bit6	bit5	bit4	bit3	bit2	bit1	bit0
F6	F5	F4	F3	F2	F1	F0	E1

 **ATTENTION:**

Parameters of Groups A0 and A1 are always displayed and are not subject to A1-20 and A1-21 show/hide control.

Example:

Besides parameter Groups A0 and A1, the groups b0, b1, b2, C0, C1, C2, C3, d0, d1 and E1 are also requested to display, just set:

A1-20 to 037F (A1-20 is 0000 0011 0111 1111 in binary)

A1-21 to 0001 (A1-21 is 0000 0000 0000 0001 in binary)

A1-22	Fault masking	Range: 00~FF	Factory default: 08
-------	---------------	--------------	------------------------

0~FF

Ones place: binary Bit3Bit2Bit1Bit0

Set Bit place to 0 is to unmask, while set it to 1 is to mask

Bit0: GdP fault , Bit1: SP1 fault , Bit2: SP2 fault, Bit3: CPU fault

Tens place: binary Bit3Bit2Bit1Bit0

Set Bit place to 0 is to unmask, while set it to 1 is to mask

Bit0: AIP fault, Bit1: OL3 fault, Bit2: oCR fault, Bit3: reserved

 **ATTENTION:**

For example: if GdP, SP1, SP2, and CPU faults need to be masked, then set ones place as hexadecimal F (set binary Bit3Bit2Bit1Bit0 to 1), meaning of tens place is similar.

Group b Run Parameter Setting

Group b0 Frequency Setting

Frequency setting is set by parameter Group b0. See Fig. 6-1 for logical relation of FREQ set.

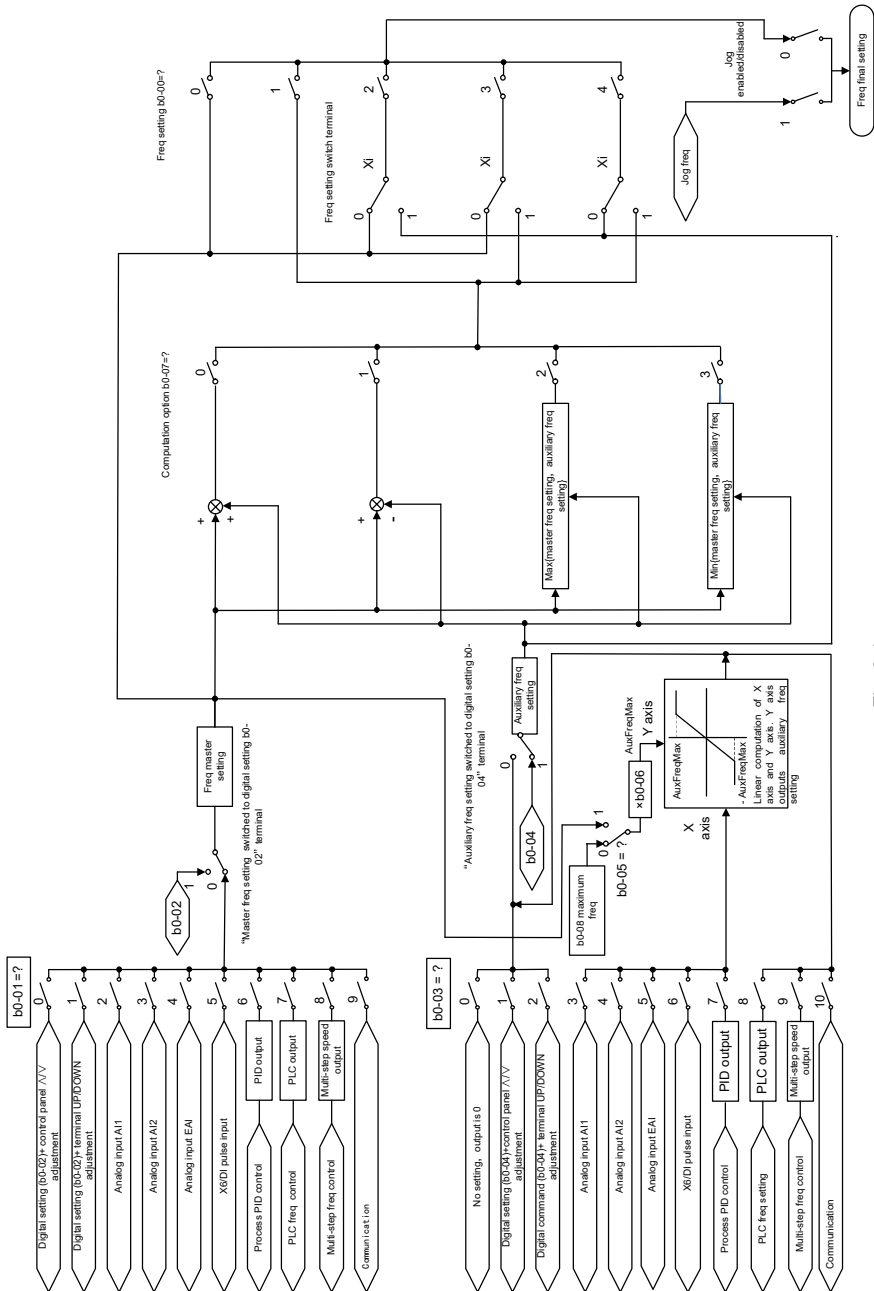

Fig. 6-1

b0-00	Frequency set mode	Range: 0~4	Factory default: 0
-------	--------------------	------------	-----------------------

0: Master FREQ set

Output frequency of drive is determined by master frequency set source b0-01. Refer to parameters b0-01 and b0-02 for further information.

1: Master & auxiliary computation result

Frequency set is the result of master & auxiliary computation. The master & auxiliary computation relation is determined by b0-07. Master frequency is set by b0-01, while auxiliary is set by b0-03.

2: Switch between master and auxiliary set

When b0-00 is set to 2, the switch between master frequency set, and auxiliary frequency set can be realized through digital input terminal "frequency set switchover". When terminal "frequency set switchover" is invalid, frequency set of the drive will be determined by b0-01. When terminal "frequency set switchover" is valid, frequency set of the drive will be determined by b0-03 (Auxiliary frequency set source).

3: Switch between master FREQ set, and master & auxiliary computation result

When b0-00 is set to 3, frequency is determined by master frequency set, or master & auxiliary computation result through digital input terminal "frequency set switchover". When terminal "frequency set switchover" is invalid, frequency is determined by b0-01 (master frequency set source). When terminal "frequency set switchover" is valid, frequency is determined by master & auxiliary computation result. The master & auxiliary computation relation is determined by b0-07.

4: Switch between auxiliary FREQ set, and master & auxiliary computation result

When b0-00 is set to 4, frequency is determined by auxiliary frequency set, or master & auxiliary computation result through digital input terminal "frequency set switchover". When terminal "frequency set switchover" is invalid, frequency is determined by b0-03 (auxiliary frequency set source). When terminal "frequency set switchover" is valid, frequency is determined by master & auxiliary computation result. The master & auxiliary computation relation is determined by b0-07.

b0-01	Master frequency set	Range: 0~9	Factory default: 0
-------	----------------------	------------	-----------------------

0: Digital setting (b0-02) + \wedge/\vee adjustment on control panel

When the drive is powered up, the value of b0-02 is taken as the master frequency set which can be adjusted through \wedge/\vee keys on control panel no matter the drive is running or in stop.

ATTENTION:

Frequency adjustment via \wedge/\vee on control panel can be cleared through terminal "UP/DOWN (including \wedge/\vee key) adjustment clear". Refer to C0-01~C0-10 for details.

1: Digital setting (b0-02) + terminal UP/DOWN adjustment

When the drive is powered up, the value of b0-02 is taken as the master frequency set. This frequency can be adjusted via "terminal UP" and "terminal DOWN" no matter the drive is running or in stop.

When this parameter value is selected, following parameter setting should be performed:

- 1) Set the two digital input terminals to "terminal UP" and "terminal DOWN" respectively. Refer to C0-01~C0-10 for further information.
- 2) Set terminal UP/DOWN frequency change step size (C0-18).
- 3) Set C0-17 (terminal UP/DOWN frequency adjustment treatment).

ATTENTION:

Frequency adjustment via terminal UP and DOWN can be cleared through terminal "UP/DOWN (including \wedge/\vee key) adjustment clear". Refer to C0-01~C0-10 for details.

2: Analog input AI1

(0~10V) voltage input and (0~20mA) current input are optional for AI1, which can be selected using jumper switch S2 on control board. It is shown as Figure 6-2.



Fig. 6-2

Refer to specification of C2-00~C2-20 for corresponding relation between analog input and output frequency. See parameter Group C4 for automatic correction of analog input.

3: Analog input AI2

AI2 input is the -10V~+10V voltage input, and the plus/minus of voltage determines the motor running direction. Refer to detailed description of C2-00~C2-20 for corresponding relation between analog value and frequency value. See parameters of Group C4 for automatic correction of analog input.

4: Analog input EAI (on IO option board)

Terminal EAI is located at IO option board, supporting 0~10V voltage input and 0~20mA current input. It can be used with the same way as AI1. When using external voltage/current analog input to the drive, the connection diagram is shown as Fig. 6-3:

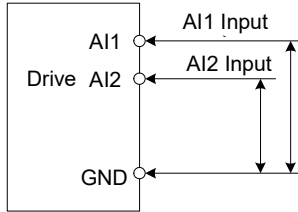

Fig. 6-3

If 10V power supply inside the drive is used with potentiometer, the connection diagram is shown as Fig. 6-4. Note that the jumper switch should be switched to voltage input side.

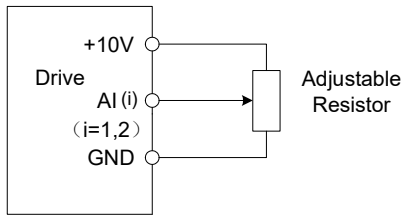

Fig. 6-4

5: X6/DI pulse input

If this parameter value is selected, frequency is determined by pulse frequency input via terminal X6/DI only. In such a case, C0-06 should be set to 24. Corresponding relation between pulse frequency and frequency set is specified in C2-24~C2-27.

6: Process PID output

Frequency is set by process closed-loop PID computation result. See parameter Group F0 for details.

7: PLC

Frequency is set by simple PLC. See parameter Group F2 for details.

8: Multi-step speed

A total of 16-step speed settings can be realized through status combination of "multi-step frequency terminal 1~4". See the table below for details. Frequency can be switched via different combination of multi-step frequency terminals no matter in running or in stop.

Table 6-4

Multi-step frequency terminal 4	Multi-step frequency terminal 3	Multi-step frequency terminal 2	Multi-step frequency terminal 1	Frequency Setting
OFF	OFF	OFF	OFF	Multi-step frequency 0 (F1-00)
OFF	OFF	OFF	ON	Multi-step frequency 1 (F1-01)
OFF	OFF	ON	OFF	Multi-step frequency 2 (F1-04)
OFF	OFF	ON	ON	Multi-step frequency 3 (F1-05)
OFF	ON	OFF	OFF	Multi-step frequency 4 (F1-06)
OFF	ON	OFF	ON	Multi-step frequency 5 (F1-07)
OFF	ON	ON	OFF	Multi-step frequency 6 (F1-08)
OFF	ON	ON	ON	Multi-step frequency 7 (F1-09)
ON	OFF	OFF	OFF	Multi-step frequency 8 (F1-10)
ON	OFF	OFF	ON	Multi-step frequency 9 (F1-11)
ON	OFF	ON	OFF	Multi-step frequency 10 (F1-12)
ON	OFF	ON	ON	Multi-step frequency 11 (F1-13)
ON	ON	OFF	OFF	Multi-step frequency 12 (F1-14)
ON	ON	OFF	ON	Multi-step frequency 13 (F1-15)
ON	ON	ON	OFF	Multi-step frequency 14 (F1-16)
ON	ON	ON	ON	Multi-step frequency 15 (F1-17)

9: Communication

Upper computer/device is the master frequency set source of the drive through standard RS485 communication interface on the drive.

refer to Group H0 and appendix on this manual for further information about communication protocol, and programming, etc.

ATTENTION:

Master frequency can be forcibly switched to b0-02 via terminal "master frequency switched to digital setting b0-02". When this terminal is disabled, master frequency is determined by b0-01. When terminal is enabled, master frequency shall be the value of b0-02.

b0-02	Master FREQ digital setting	Range: lower limit frequency ~ upper limit frequency	Factory default: 50.00Hz
-------	-----------------------------	--	--------------------------

When master frequency setting b0-01 value is set to either 0 or 1, this parameter value will be the initial value of master frequency setting.

b0-03	Auxiliary FREQ set	Range: 0~10	Factory default: 0
-------	--------------------	-------------	--------------------

0: No setting

Auxiliary frequency command is disabled, and auxiliary frequency is 0.

1: Digital setting (b0-04) + \wedge/\vee adjustment on control panel

When the drive is powered up, the value of b0-04 is auxiliary frequency command, also can be adjusted through \wedge/\vee on control panel no matter the drive is running or in stop status.

ATTENTION:

When master frequency command involves \wedge/\vee adjustment on control panel, \wedge/\vee involving auxiliary frequency command shall be disabled.

2: digital setting (b0-04) + terminal UP/DOWN adjustment

When the drive is powered up, the value of b0-04 is current auxiliary frequency command. Whether the drive is running or stopped, current auxiliary frequency setting can be adjusted through digital input terminals "UP" and "DOWN". Just set "terminal UP/DOWN frequency adjustment treatment" and "terminal UP/DOWN frequency change step size" through C0-17 and C0-18.

ATTENTION:

When master frequency setting involves terminal UP/DOWN adjustment, UP/DOWN adjustment involving auxiliary frequency setting shall be disabled.

3: Analog input AI1

4: Analog input AI2

5: Analog input EAI (on IO option board)

AI1 and EAI can be either (0~10V) voltage input or (0~20mA) current input which can be switched by the jumper switch on control board or IO option board. AI2 input is -10V~+10V input only, and the plus/minus of the voltage determines the motor running direction.

ATTENTION:

When analog input channel of auxiliary frequency set is the same with that of master frequency set, analog input channel of auxiliary frequency set would be disabled. See b0-05 and b0-06 for information, about frequency relation that corresponds to maximum value of analog input of auxiliary frequency .

6: X6/DI pulse input

Auxiliary frequency command is determined by pulse frequency via terminal X6/DI only. In such a case, set X6/DI terminal to "pulse input"(set C0-06 to 24). Refer to C2-24~C2-27 for corresponding relationship between pulse frequency and command frequency.

ATTENTION:

In case X6/DI pulse input is also set for master frequency command source, the pulse input for auxiliary frequency command shall be disabled. See b0-05 and b0-06 for information about frequency relation that corresponds to maximum value of pulse input for auxiliary frequency command.

7: Process PID output

Auxiliary frequency setting is determined by process PID computation result. See parameter Group F0 for details.

ATTENTION:

In case PID output is also set for master frequency setting, the process PID output for auxiliary frequency setting would be disabled. See b0-05 and b0-06 for information about frequency relation that corresponds to maximum value of process PID output for auxiliary frequency setting.

8: PLC

Auxiliary frequency setting is determined by simple PLC. See parameter Group F2 for details.

ATTENTION:

In case simple PLC program output is also set for master frequency setting, the PLC for auxiliary frequency setting would be disabled.

9: Multi-step speed

A total of 16-step speed settings can be realized through status combination of "multi-step frequency terminal 1~4". Frequency setting can be switched via different combination of multi-step frequency terminals no matter in running or in stop.

ATTENTION:

In case master frequency setting is also set to multi-step speed, the multi-step speed output for auxiliary frequency setting would be disabled.

10: Communication

Upper computer is the auxiliary frequency set source of the drive through standard RS485 communication interface on the drive. Refer to Group H0 and appendix on this manual for further information about communication protocol, and programming, etc.

 **ATTENTION:**

Auxiliary frequency setting can be forcibly switched to b0-04 via terminal "auxiliary frequency setting switched to digital setting b0-04". When this terminal is disabled, master frequency setting is determined by b0-03. When terminal is enabled, master frequency setting shall be the value of b0-04.

b0-04	Auxiliary FREQ digital setting	Range: lower limit frequency ~ upper limit frequency	Factory default: 0.00Hz
-------	--------------------------------	--	-------------------------

When auxiliary frequency command is set to either 1 or 2, this parameter value should be the initial value of auxiliary frequency command.

b0-05	Auxiliary FREQ range	Range: 0~1	Factory default: 0
-------	----------------------	------------	--------------------

0: Relative to maximum frequency

1: Relative to master frequency

See b0-06 specification for details.

b0-06	Auxiliary FREQ coeff	Range: 0.0%~100.0%	Factory default: 100.0%
-------	----------------------	--------------------	-------------------------

When b0-03 selects AI1, AI2, EAI, X6/DI pulse input, or process PID output as auxiliary frequency command sources, b0-05 and b0-06 will determine the final output value of auxiliary frequency command.

When b0-05 is set to 0 (relative to maximum frequency): When AI1, AI2, EAI, X6/DI pulse input is selected for auxiliary frequency command, the frequency that corresponds to maximum value of the source should be $(b0-08 \times b0-06)$.

Example:

Select AI1 as auxiliary frequency command source (set b0-03 to 3) and set AI1 to curve 1 (Ones place of C2-00 is 0) as shown in Fig. 6-5. In such a case, the frequency that corresponds to the maximum input of curve 1 should be: $(C2-02) \times [(b0-08) \times (b0-06)]$.

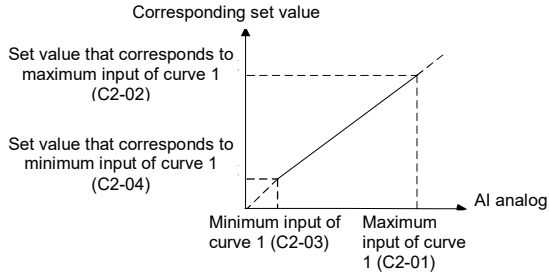

Fig. 6-5

When X6/DI pulse input is selected as auxiliary frequency command (set b0-03 to 6), the frequency that corresponds to maximum DI input should be: $(C2-25) \times [(b0-08) \times (b0-06)]$. When PID is selected for auxiliary frequency command, the frequency that corresponds to maximum value of PID output should be $(b0-08) \times (b0-06)$. PID output diagrammatic sketch is as shown in Fig. 6-6.

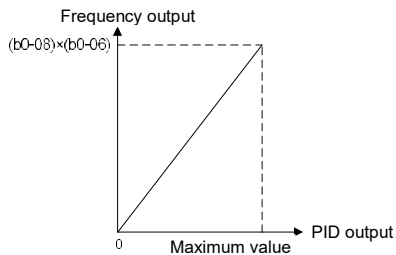

Fig. 6-6

When b0-05 is set to 1 (relative to master frequency): When AI1, AI2, EAI, or X6/DI pulse input is selected for auxiliary frequency command source, the frequency that corresponds to maximum value of these sources should be: $[\text{master frequency} \times (b0-06)]$.

Example:

When selecting AI1 as auxiliary frequency command source (set b0-03 to 3) and setting AI1 to curve 1 (Ones place of C2-00 is 0), the frequency that corresponds to maximum input of curve 1 should be: $(C2-02) \times [\text{master frequency} \times (b0-06)]$.

When X6/DI pulse input is selected as auxiliary frequency command source (set b0-03 to 6), the frequency that corresponds to maximum DI input should be: $(C2-25) \times [\text{master frequency} \times (b0-06)]$.

When PID is selected for auxiliary frequency command, the frequency that corresponds to maximum value of PID output should be $[\text{master frequency} \times (b0-06)]$. PID output diagram is as shown in Fig. 6-7.

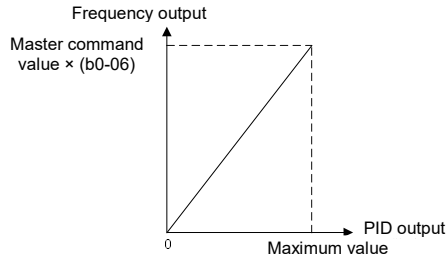

Fig. 6-7

b0-07	Computation of master and auxiliary FREQ	Range: 0~3	Factory default: 0
-------	--	------------	--------------------

0: Master + auxiliary

The sum of master and auxiliary frequency is taken as frequency command. Output result is subject to limitation of upper and lower limit frequency.

1: Master - auxiliary

The difference between master and auxiliary frequency is taken as frequency command. Output result is subject to limitation of upper and lower limit frequency.

2: Max {master, auxiliary}

Master frequency or auxiliary frequency (whichever has a larger absolute value) is taken as frequency command. Output result is subject to limitation of upper and lower limit frequency.

3: Min {master, auxiliary}

Master frequency or auxiliary frequency (whichever has a smaller absolute value) is taken as frequency command. Output result is subject to limitation of upper and lower limit frequency.

b0-08	Maximum frequency	Range: Upper limit frequency ~600.00Hz	Factory default: 50.00Hz
b0-09	Upper limit frequency	Range: Lower limit frequency ~ maximum frequency	Factory default: 50.00Hz
b0-10	Lower limit frequency	Range: 0.00Hz ~ upper limit frequency	Factory default: 0.00Hz

Maximum frequency of b0-08 is the maximum allowable output frequency of drive and is indicated by f_{max} in the figure.

B0-09 upper limit frequency is the user-defined maximum allowable run frequency and represented by f_H in Fig. 6-8.

B0-10 lower limit frequency is user-defined minimum allowable run frequency and marked with f_L in Fig. 6-8. In Fig. 6-8, f_N represents rated frequency of motor while V_N means the rated voltage of motor.

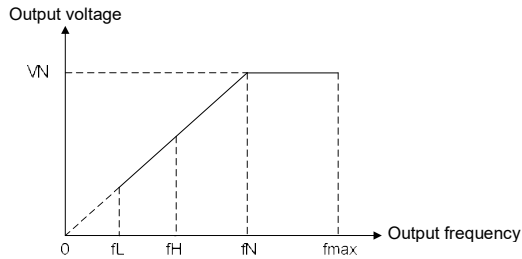

Fig. 6-8

ATTENTION:

- Maximum frequency, upper limit frequency and lower limit frequency should be set with care in accordance with nameplate parameters of motor and operation requirements.
- Jog and motor parameter identification is free from limitations of upper and lower limit frequency.
- In addition to limitation of upper limit frequency and lower limit frequency, the output frequency is also subject to limitations of starting frequency, stop DC brake initial frequency, skip frequency and other parameter settings.
- The rank relation between maximum frequency, upper limit frequency and lower limit frequency is shown as Fig. 6-8.
- Upper and lower limit frequencies restrict actual output frequency to motor. If command frequency is higher than upper limit frequency, the running would be at upper limit frequency. In case command frequency is lower than lower limit frequency, the running should be in accordance with the setting of b0-11.

b0-11	Operation when set FREQ lower than lower limit FREQ	Range: 0~2	Factory default: 0
-------	---	------------	--------------------

0: Run at lower limit frequency

In case frequency setting is lower than lower limit frequency, the run should be at lower limit frequency.

1: Run at 0Hz

In case the frequency setting is lower than lower limit frequency, the run should be at 0Hz.

2: Stop

If frequency setting is lower than lower limit frequency, stop would be activated after the time delay set by b0-12. When lower limit frequency is 0, this limitation is invalid.

ATTENTION:

This parameter is disabled under PID control mode.

b0-12	Time-delay of stop when set FREQ lower than lower limit FREQ	Range: 0.0s~6553.5s	Factory default: 0.0s
-------	--	---------------------	--------------------------

When b0-11 is set to 2, and frequency setting is lower than lower limit frequency, the drive will stop running after this parameter value.

b0-13	Lower limit of skip FREQ band 1	Range: 0.00Hz ~ upper limit frequency	Factory default: 0.00Hz
b0-14	Upper limit of skip FREQ band 1	Range: 0.00Hz ~ upper limit frequency	Factory default: 0.00Hz
b0-15	Lower limit of skip FREQ band 2	Range: 0.00Hz ~ upper limit frequency	Factory default: 0.00Hz
b0-16	Upper limit of skip FREQ band 2	Range: 0.00Hz ~ upper limit frequency	Factory default: 0.00Hz
b0-17	Lower limit of skip FREQ band 3	Range: 0.00Hz ~ upper limit frequency	Factory default: 0.00Hz
b0-18	Upper limit of skip FREQ band 3	Range: 0.00Hz ~ upper limit frequency	Factory default: 0.00Hz

Skip frequency is a function designed to prevent the drive run at resonance zone of mechanical system. At most 3 skip zones can be defined. See Fig. 6-9.

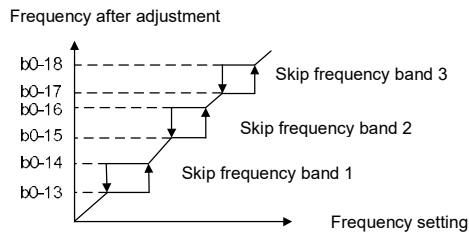

Fig. 6-9

Once parameters of skip zones are set, the output frequency of the drive would automatically get out of these skip zones even if the frequency setting is within these zones.

ATTENTION:

Output frequency of drive can normally pass through skip zones during Accel and Decel.

b0-19	Jog frequency	Range: 0.00Hz ~ upper limit frequency	Factory default: 5.00Hz
-------	---------------	--	----------------------------

This parameter sets the running frequency during jog. Jog Accel time is set by parameter b2-10 while its Decel time by parameter b2-11. Jog run command control could be performed through

control panel, control terminals or communication input. Multifunction MF key can be set as forward jog or reverse jog key through parameter L0-00.

Jog can be realized using "forward jog terminal" and "reverse jog terminal" of DI, as well as via communication input. See drive communication protocol for further information. See Jog diagrammatic sketch 6-10.

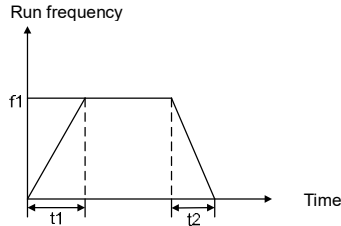

Fig. 6-10

Thereof:

$f1$ is jog frequency b0-19. $t1$ represents the Accel time from zero to jog frequency, $t1 = (b2-10) \times f1/(b0-08)$. $b0-08$ is the maximum frequency. $t2$ is the Decel time from jog frequency to 0, $t2 = (b2-11) \times f1/(b0-08)$.

ATTENTION:

Jog frequency set value is free from limitations of upper and lower limit frequency. Jog is started from starting frequency and its start is not subject to limitation by b1-05. When the jog frequency is set smaller than starting frequency, the drive will run at 0Hz.

b0-20	Zero clearing when master and auxiliary FREQ is switching	Range: 0~1	Factory default:0
-------	---	------------	-------------------

0~1

0: zero clearing

1: No zero clearing

Group b1 Start/Stop Control

b1-00	Run command	Range: 0~2	Factory default: 0
-------	-------------	------------	--------------------

This parameter sets run command source. Run commands include "start, stop, forward and reverse", etc.

0: Control panel control

Control run command through RUN, STOP/RESET and MF keys on control panel (set multifunction key MF to JOG by L0-00). Refer to Chapter 4 about the operation of control panel.

1: Terminal control

Control run command via DI terminals. Perform FORWARD and REVERSE by DI terminals. The control mode is two-wire mode and three-wire mode selectable. See Group C0 for details of designation and wiring regulation of DI terminals.

2: Communication control

Master device is able to control run command through built-in RS485 serial communication interface of drive. Refer to parameters Group H0 and appendix for further information about programming.

Run command from control panel, terminals and communication can be switched by terminals "run command switched to control panel control", "run command switched to terminal control" and "run command switched to communication control".

Multifunction key MF can be set to "run command sources shifted" key through parameter L0-00. When MF key is pressed under this setting, run command will be shifted during control panel control, terminal control and communication control circularly.

b1-01	Binding of run command and frequency set	Range: 000 ~ AAA	Factory default: 000
-------	--	------------------	----------------------

This parameter defines the bundled combination of three run command sources and frequency set with the purpose of facilitating simultaneous switching. For example: frequency setting AI1 (ones place of b1-01 is set to 3) bundled with control panel control, while the frequency setting X6/DI pulse input (ten's place of b1-01 is set to 6) bundled with terminal control. In such a case, when run command is controlled by control panel, frequency setting would be AI1, while when run command is controlled via terminals, frequency setting will be automatically switched to X6/DI pulse input.

◆ Ones place: frequency setting bundled under control panel control

0: No binding

1: Digital setting (b0-02) + \wedge/\vee adjustment on control panel

2: Digital setting (b0-02) + terminal UP/DOWN adjustment

3: Analog input AI1

4: Analog input AI2

5: Analog input EAI (on IO option board)

6: X6/DI pulse input

7: Process PID output

8: Simple PLC

9: Multi-step frequency

A: Communication input

Refer to parameter b0-01 for details regarding above-mentioned sources of frequency setting.

◆ Tens place: frequency setting bundled under terminal control (same as ones place)

◆ Hundreds place: frequency setting bundled under communication control (same as ones place)

ATTENTION:

Different run command sources can be bundled with the same frequency setting source. The priority of frequency setting sources bundled with run command overrides Group b0.

b1-02	Run direction	Range: 0~1	Factory default: 0
-------	---------------	------------	--------------------

This parameter applies to run command controlled by control panel, and disabled under terminal and communication control.

0: Forward

1: Reverse

b1-03	Reverse disabled	Range: 0~1	Factory default: 0
-------	------------------	------------	--------------------

0: Reverse enabled

1: Reverse disabled

In some applications, reverse is likely to result in equipment damage. This parameter is used to prevent reverse running.

b1-04	Dead time between forward and reverse	Range: 0.0s ~ 3600.0s	Factory default: 0.0s
-------	---------------------------------------	-----------------------	-----------------------

The dead time in 0Hz output during the transition from forward to reverse, or from reverse to forward, is indicated by letter "t" in Fig. 6-11.

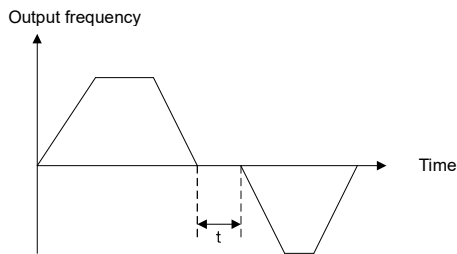

Fig. 6-11 Dead time between forward and reverse

b1-05	Start method	Range: 0~5	Factory default: 0
-------	--------------	------------	--------------------

This parameter takes effect during the process of transition from stop status to run status.

0: From start frequency

When drive starts to run from stop status, it starts from start frequency (b1-06) and keeps this frequency for a period of time set by b1-07, and then accelerated to set frequency in accordance with the Accel method and time.

1: DC braking start

To make the motor stop completely before a new start, the drive will perform DC braking with a certain period of time, as specified by b1-08 and b1-09, then start from start frequency

(b1-06), keeping a period of time as specified by b1-07, and then Accelerate to set frequency.

- 2: Flying start 1
- 3: Flying start 2
- 4: Flying start 3
- 5: Flying start 4

When this parameter is set to 2 or 3, the drive will detect the motor rotary speed in order to perform a smooth start from the detected rotary speed. This start method is applicable to the restart on momentary power loss, like rotating fan, etc. When this parameter value is set to flying start 1, motor parameters and b1-10~b1-12 needs to be set correctly and appropriately. When it is set to flying start 2, option board EPC-VD2 must be required. In general, for motor restart, flying start 2 is much smoother than flying start 1, as it has the assistance of option board EPC-VD2.

When the parameter is set to 3 or 4, please correctly set motor parameter of b1-10 ~ b1-12. There is no need of EPC-VD2 board, with high robustness, and insensitive to motor parameter. Flying start 4 has a higher accuracy, which is a more commonly used mode for software speed search.

b1-06	Start FREQ	Range: 0.00Hz ~ upper limit frequency	Factory default: 0.00Hz
b1-07	Holding time of start FREQ	Range: 0.0s ~ 3600.0s	Factory default: 0.0s

Start frequency is initial output frequency of drive start from stop status. Start frequency holding time is the continuous run time with start frequency. After this holding time, the drive will Accelerate to set frequency. Usually appropriate start frequency and holding time assure the starting torque of heavy-duty load.

Provided that set frequency is lower than start frequency, drive output frequency is 0 Hz. Start frequency and start frequency holding time take effect at the moment of motor start, as well as the transfer between forward and reverse. Accel time at Group b2 excludes the holding time of start frequency.

b1-08	DC braking current at start	Range: 0.0%~200.0%	Factory default: 0.0%
b1-09	DC braking time at start	Range: 0.00s~30.00s	Factory default: 0.00s

When the motor is started by the method "DC braking start", it is essential to set these two parameters.100% corresponds to rated current of drive. If braking time is set to 0.0s, DC braking at start is disabled.

b1-10	Flying start 1 current	Range: 0~200.0%	Factory default: 100.0%
-------	------------------------	-----------------	-------------------------

When b1-05 is set to 2, flying start 1 current should be set appropriately. 100% corresponds to drive rated current. When drive output current is less than this parameter value, it is deemed that drive output frequency is the same as motor speed and the flying operation is finished.

b1-11	Flying start 1 Decel time	Range: 0.1s~20.0s	Factory default: 2.0s
-------	---------------------------	-------------------	--------------------------

This parameter takes effect when b1-05 is set to 2, flying start 1. This time setting refers to the time drive deceleration from maximum frequency to 0. The shorter the flying start Decel time is, the faster the flying start will be. However, excessively rapid flying start brings about inaccuracy of flying start.

b1-12	Flying start 1 adjustment coeff	Range: 0.0~100.0%	Factory default: 1.0%
-------	---------------------------------	-------------------	--------------------------

When the start method is set to flying start (b1-05=2 or 3), a suitable flying start adjustment coeff can suppress the output current during the process of flying start thus improve the smoothness of flying start.

b1-13	Stop method	Range: 0~2	Factory default: 0
-------	-------------	------------	--------------------

0: Ramp to stop

Upon the receipt of stop command, drive gradually decreases output frequency according to the set Decel time, and stop when frequency attains 0.

1: Coast to stop

Upon the receipt of stop command, drive will immediately lock the output and the motor will stop with its mechanical inertia.

2: Ramp to stop + DC brake

Upon the receipt of stop command, drive will decrease output frequency in accordance with the rate of Decel time setting. Once the output frequency attains set value of b1-14, DC braking will be enabled, and the drive will stop after the finish of DC braking.

b1-14	Start frequency of DC brake stop	Range: 0.00Hz ~ upper limit frequency	Factory default: 0.00Hz
b1-15	DC brake current	Range: 0.0%~200.0%	Factory default: 0.0%
b1-16	DC Brake time	Range: 0.00s~30.00s	Factory default: 0.00s

During the process "ramp to stop + DC braking", DC brake would be started when output frequency attains the set value of b1-14. b1-15 defines brake level, in amps, applied to the motor. 100% corresponds to rated current of drive. b1-16 sets the duration of time that DC brake current works when b1-13 is set to 2. In case b1-16 is set to 0.0s, DC brake shall be disabled.

If "DC brake stop" terminal is enabled, this terminal time duration or b1-16 set time, whichever is longer, would be taken as stop brake time.

b1-17	Overexcitation brake	Range: 0~1	Factory default: 1
-------	----------------------	------------	--------------------

0: Disabled

1: Enabled

When overexcitation brake is enabled in case of stop by Decel, the motor shall transform the electric energy generated during Decel into heat energy by increasing magnetic flux so as to attain rapid stop. If this parameter is enabled, the Decel time will be shortened. If overexcitation brake is disabled, the Decel current of motor will decrease and the Decel time will be prolonged.

b1-18	Dynamic brake	Range: 0~1	Factory default: 0
-------	---------------	------------	--------------------

0: Disabled

1: Enabled

When dynamic brake is enabled, the electric energy generated during Decel shall be converted into heat energy consumed by brake resistor, so as to attain rapid Decel. This brake method applies to brake of high-inertia load or the situations that require quick stop. In such a case, it is necessary to select appropriate dynamic brake resistor and brake unit. The drives equal and below 15kW are provided with a standard built-in brake unit. Built-in brake chopper is optional for drives 18.5kW~75kW.

No matter built-in brake or external mounted brake is used, when dynamic brake is adopted , b1-18 shall be set to 1.

b1-19	Dynamic brake threshold voltage	Range: 650V~750V	Factory default: 720V
-------	---------------------------------	------------------	-----------------------

This parameter takes effect only to the drives with built-in brake chopper. If b1-18 is set to 1: when bus voltage of drive attains the value of b1-19, dynamic brake shall perform. The energy shall be rapidly consumed through brake resistor. This value is used to regulate the brake effect of brake chopper.

b1-20	Auto restart when power up again after power loss	Range: 0~1	Factory default: 0
-------	---	------------	--------------------

Defines the drive status when power up again after power loss during running

0: Disabled

The drive will not run automatically when power is up after power loss.

1: Enabled.

When run command is controlled by control panel or communication, the drive will run automatically when power is up again after power loss. When run command is controlled by terminals, the drive will run automatically only if ON signal from run command terminal is detected.

ATTENTION:

Enable this parameter with caution for safety consideration.

b1-21	Time delay of auto restart when power up again	Range: 0.0s~10.0s	Factory default: 0.0s
-------	--	-------------------	-----------------------

This time setting should consider work restoration time of relative devices in the system when power is up again after power loss, on the premise that b1-20 is set to 1.

Group b2 Accel/Decel Parameters

b2-00	Accel/Decel time resolution	Range: 0~2	Factory default: 1
-------	-----------------------------	------------	--------------------

0: 0.01s; the setting range of Accel/Decel time is 0.00s~600.00s

1: 0.1s; the setting range of Accel/Decel time is 0.0s~6000.0s

2: 1s; the setting range of Accel/Decel time is 0s~60000s

Accel/Decel time resolution takes effect on b2-01~b2-11.

b2-01	Accel time 1	Range: 0s~60000s	Factory default: 6.0s
b2-02	Decel time 1	Range: 0s~60000s	Factory default: 6.0s
b2-03	Accel time 2	Range: 0s~60000s	Factory default: 6.0s
b2-04	Decel time 2	Range: 0s~60000s	Factory default: 6.0s
b2-05	Accel time 3	Range: 0s~60000s	Factory default: 6.0s
b2-06	Decel time 3	Range: 0s~60000s	Factory default: 6.0s
b2-07	Accel time 4	Range: 0s~60000s	Factory default: 6.0s
b2-08	Decel time 4	Range: 0s~60000s	Factory default: 6.0s

These parameters b2-01~b2-08 set the rate of Accel/Decel for speed increase/decrease.

Maximum Freq (b0-08) / Accel time X = Accel Rate X

Maximum Freq (b0-08) / Decel time X = Decel Rate X

As the formula sets forth above, Accel time means required time for drive to Accelerate to maximum frequency b0-08 from zero frequency, while Decel time refers to the time required for drive to Decelerate to zero frequency from maximum frequency b0-08. These four Accel/Decel times can be selected through the ON/OFF combination of DI terminals" Accel/Decel time determinant 1" and " Accel/Decel time determinant 2". See Table 6-5.

Table 6-5

Accel/Decel time determinant 2	Accel/Decel time determinant 1	Accel/Decel time
OFF	OFF	Accel/Decel time 1(b2-01, b2-02)
OFF	ON	Accel/Decel time 2(b2-03, b2-04)
ON	OFF	Accel/Decel time 3(b2-05, b2-06)
ON	ON	Accel/Decel time 4(b2-07, b2-08)

ATTENTION:

- When the drive is running under simple PLC, the Accel time and Decel time are determined by simple PLC related parameters, not by the DI terminals. See Group F2 for details.
- When Accel/Decel of broken-line style is selected, Accel/Decel time is automatically switched to Accel/Decel time 1 and 2 according to switching frequency (b2-13 and b2-14). Under this circumstance, Accel/Decel time selection terminals are disabled.

b2-09	Decel time for emergency stop	Range: 0s~60000s	Factory default: 6.0s
-------	-------------------------------	------------------	-----------------------

In case of emergency stop via multifunction MF key on control panel (MF key has been set to emergency stop 1 through parameter L0-00), or via DI terminal "emergency stop", Decel is conducted according to this time. This parameter sets the rate of Decel for speed decrease, like b2-01~b2-08.

b2-10	Jog Accel time	Range: 0s~60000s	Factory default: 6.0s
b2-11	Jog Decel time	Range: 0s~60000s	Factory default: 6.0s

b2-10 and b2-11 set the rate of Jog Accel/Decel, like b2-01~b2-08.

b2-12	Accel/Decel curve	Range: 0~4	Factory default: 0
-------	-------------------	------------	--------------------

0: Linear Accel/Decel

Outputs frequency increases or decreases with a constant rate as shown in Fig. 6-12.

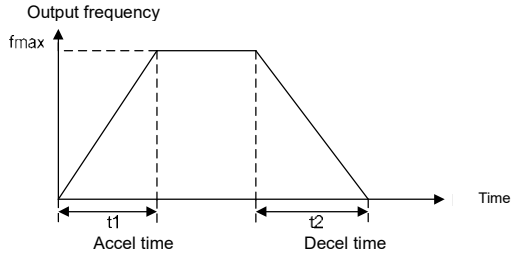

Fig. 6-12

fmax is maximum frequency b0-08.

1: Broken-line Accel/Decel

Accel/Decel time is shifted based on output frequency during Accel/Decel. When output frequency during Accel is higher than or equal to b2-13 (Accel time switching frequency of broken-line Accel/Decel), b2-01 (Accel time 1) is enabled. When lower than b2-13, b2-03 (Accel time 2) will be enabled.

When output frequency during Decel is higher than or equal to b2-14 (Decel time switching frequency of broken-line Accel/Decel), b2-02 (Decel time 1) is enabled. When lower than b2-14, b2-04 (Decel time 2) will be enabled.

ATTENTION:

When broken-line Accel/Decel is enabled, "Accel/Decel time determinant 1" and "Accel/Decel time determinant 2" will be disabled.

Broken-line Accel/Decel is as shown in Fig. 6-13.

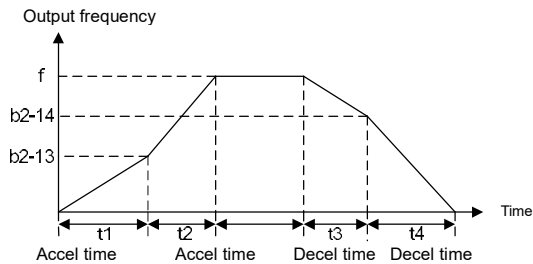

Fig. 6-13

$$t1 = (b2-03) \times (b2-13) / (b0-08) \qquad t2 = (b2-01) \times [f - (b2-13)] / (b0-08)$$

$$t3 = (b2-02) \times [f - (b2-14)] / (b0-08) \qquad t4 = (b2-04) \times (b2-14) / (b0-08)$$

f is current frequency set, and b0-08 is maximum frequency.

2: S-curve Accel/Decel A

By adding a period of S-curve time to the first and last segments of Accel/Decel, it can improve the smoothness of start/stop and prevent mechanical impact. See Fig. 6-14:

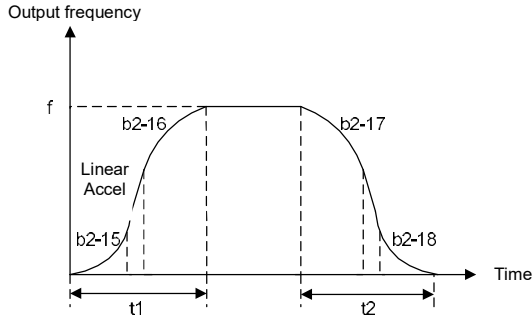

Fig. 6-14

Accel/Decel rate changes gradually at the first and last segments of S-curve time. At the middle segment of S-curve, it is linear Accel/Decel rate, which is determined by enabled Accel/Decel time 1~4. Therefore, the actual Accel/Decel time is longer than linear Accel/Decel if this parameter value is selected.

$$\text{Actual Accel time} = \text{linear Accel time} + (\text{Time of first segment of Accel S-curve} + \text{Time of last segment of Accel S-curve})/2$$

$$\text{Actual Decel time} = \text{linear Decel time} + (\text{Time of first segment of Decel S-curve} + \text{Time of last segment of Decel S-curve})/2$$

Example:

Assuming that the maximum frequency b0-08 is 50Hz and the Accel time set is 6s, the linear Accel time from initial status 10Hz to 40Hz = $6s \times (40Hz-10Hz)/50Hz = 3.6s$

Assuming b2-15 = 0.20s and b2-16 = 0.40s, the actual Accel time under "S-curve Accel/Decel A" = $3.6s + (0.20s + 0.40s)/2 = 3.9s$.

ATTENTION:

Provided the above-noted calculated linear Accel time is less than $(\text{Time of first segment of Accel S-curve} + \text{Time of last segment of Accel S-curve})/2$, there will not be linear part. Decel is the same as above.

3: S-curve Accel/Decel B

Schematic diagram is shown as Fig. 6-15:

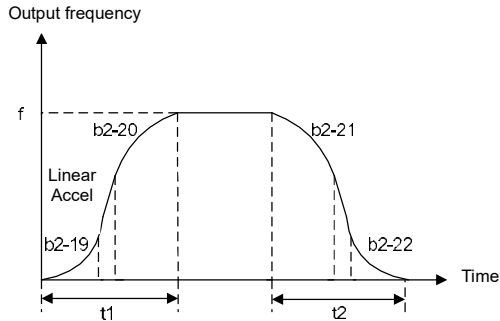

Fig. 6-15

S-curve time at first segment of Accel is $(b2-19 \times t1)$ in the figure, in which the Accel rate increases progressively. In this period, the S-curve time at last segment is $(b2-20 \times t1)$ and the Accel rate decreases gradually. At the middle of $t1$, it is linear Accel with a constant rate which is adjusted automatically based on the setting of $b2-19$ and $b2-20$.

Decel period $t2$ is similar as above.

Make sure the sum of proportions of the first and last segments is no more than 100%, i.e. the sum of set values of $b2-19$ and $b2-20$ should not exceed 100.0%, while that of $b2-21$ and $b2-22$ should not exceed 100%.

Example:

Assuming that the maximum frequency $b0-08$ is 50Hz and the Accel time setting is 6s, the linear Accel time required for Accel from initial status 10Hz to 40Hz = $6s \times (40Hz - 10Hz) / 50Hz = 3.6s$

Assuming that $b2-19 = 20.0\%$ and $b2-20 = 30.0\%$, The first segment of Accel S-curve should be $20.0\% \times 3.6s = 0.72s$; last segment of Accel S-curve should be $30.0\% \times 3.6s = 1.08s$; linear Accel time at middle segment should be $3.6s - 0.72s - 1.08s = 1.8s$.

Difference between S-curve Accel/Decel A and B: Middle-segment Accel/Decel rate of S-curve Accel/Decel A is determined by the selected Accel/Decel time 1~4, not subject to the effect of S-curve time span, therefore the total Accel/Decel time changes with the variation of setting of S-curve time.

When some certain Accel/Decel time is selected for S-curve Accel/Decel B, the total time of Accel/Decel is constant, but with different proportion of the first part and the last part, the rate of linear part as well as the shape of S-curve will change.

4: S-curve Accel/Decel C

The motor rated frequency is taken as inflection point of this S-curve, and the set Accel/Decel time is:

$$\text{Accel/Decel rate} = \text{Motor rated frequency} / \text{Accel/Decel time} \quad (\surd)$$

$$\text{NOT Accel/Decel rate} = \text{Maximum frequency} / \text{Accel/Decel time} \quad (\times)$$

When set frequency is higher than motor rated frequency, the Accel/Decel time is automatically adjusted by reducing motor output torque. This is applicable to the situation in which short Accel/Decel time is required during the speed range higher than motor rated frequency. Diagram of S-curve C is shown as Fig. 6-16:

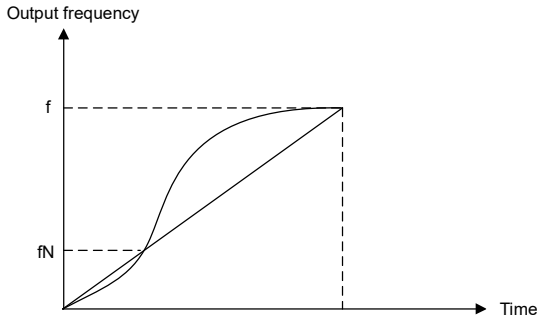

Fig. 6-16

f: Set Freq

fN: Motor rated frequency

b2-13	Accel time switching frequency of broken-line Accel/Decel	Range: 0.00Hz~maximum frequency	Factory default: 0.00Hz
b2-14	Decel time switching frequency of broken-line Accel/Decel	Range: 0.00Hz~maximum frequency	Factory default: 0.00Hz

When b2-12 is set to 1:

b2-01 (Accel time 1) is enabled when output frequency during Accel is more than or equal to set value of b2-13, while b2-03 (Accel time 2) is enabled when output frequency during Accel is less than set value of b2-13.

b2- 02 (Decel time 1) is enabled when output frequency during Decel is more than or equal to set value of b2-14, while b2-04 (Decel time 2) is enabled when output frequency during Accel is less than set value of b2-14.

ATTENTION:

When broken-line Accel/Decel is selected, terminals "Accel/Decel time determinant 1" and "Accel/Decel time determinant 2" will be disabled.

b2-15	Time of Accel S-curve first segment	Range: 0.00s~60.00s	Factory default: 0.20s
b2-16	Time of Accel S-curve last segment	Range: 0.00s~60.00s	Factory default: 0.20s
b2-17	Time of Decel S-curve first segment	Range: 0.00s~60.00s	Factory default: 0.20s
b2-18	Time of Decel S-curve last segment	Range: 0.00s~60.00s	Factory default: 0.20s

These four parameters are enabled when b2-12 is set to 2.

b2-19	Proportion of Accel S-curve first segment	Range: 0.0%~100.0%	Factory default: 20.0%
b2-20	Proportion of Accel S-curve last segment	Range: 0.0%~100.0%	Factory default: 20.0%
b2-21	Proportion of Decel S-curve first segment	Range: 0.0%~100.0%	Factory default: 20.0%
b2-22	Proportion of Decel S-curve last segment	Range: 0.0%~100.0%	Factory default: 20.0%

These four parameters are enabled when b2-12 is set to 3.

ATTENTION:

The sum of the values of b2-19 and b2-20 should not exceed 100.0%. The sum of the values of b2-21 and b2-22 also should not exceed 100.0%

Group C Input and Output Terminals**Group C0 Digital Input**

C0-00	Enabled condition of run command terminals when power up	Range: 0~1	Factory default: 0
-------	--	------------	--------------------

This parameter is only for digital terminals with parameter value 1~4 (forward/reverse jog, and forward/reverse run), and also is only for initial run after power up.

0: Trigger edge detected + ON detected

When run command is controlled by terminals, the drive will start to run when it detects that the terminal electric level jumps from OFF to ON and is kept ON after power up.

If run command terminal is in ON state before power up, the drive will not run after power up. Under this circumstance, only when the ON state is shifted to OFF and then ON again, and maintain ON, the drive will start running.

1: ON detected

When run command is controlled by terminals, the drive will start to run when detecting the command terminal at ON state after power up.

 **ATTENTION:**

When “1: ON detected” selected, the drive will start to run after power up as long as ON of run command terminal detected. Make sure of the safety of personnel and equipment before this setting.

C0-01	Function of terminal X1	Range: 0~99	Factory default: 3
C0-02	Function of terminal X2	Range: 0~99	Factory default: 4
C0-03	Function of terminal X3	Range: 0~99	Factory default: 1
C0-04	Function of terminal X4	Range: 0~99	Factory default: 23
C0-05	Function of terminal X5	Range: 0~99	Factory default: 11
C0-06	Function of terminal X6/DI	Range: 0~99	Factory default: 0
C0-07	Function of terminal EX (on IO option board)	Range: 0~99	Factory default: 0
C0-08	Function of terminal AI1 (Digital enabled)	Range: 0~99	Factory default: 0
C0-09	Function of terminal AI2 (Digital enabled)	Range: 0~99	Factory default: 0
C0-10	Function of terminal EAI (Digital enabled) (on IO option board)	Range: 0~99	Factory default: 0

Analog input terminals AI1, AI2 and EAI can also be used as digital input terminals set by C0-08~C0-10. When AI1, AI2 and EAI are used as analog input, C0-08~C0-10 shall be set to 0. Parameter setting of digital input is as shown in Table 6-6:

Table 6-6 Digital input functions

Set value	Function	Set value	Function
0	No function	26	Reserved
1	JOG forward	27	Run command switched to control panel control
2	JOG reverse	28	Run command switched to terminal control
3	Run forward (FWD)	29	Run command switched to communication control

Set value	Function	Set value	Function
4	Run reverse (REV)	30	Frequency set mode shift
5	Three-wire control	31	Master frequency set switched to digital setting b0-02
6	Run suspended	32	Auxiliary FREQ set switched to digital setting b0-04
7	External stop	33	PID adjustment direction
8	Emergency stop	34	PID paused
9	Stop command + DC brake	35	PID integration paused
10	DC brake stop	36	PID parameter switch
11	Coast to stop	37	Count input
12	Terminal UP	38	Count clear
13	Terminal DOWN	39	Length count
14	Clear UP/DOWN (including \wedge / \vee key) adjustment	40	Length clear
15	Multi-step frequency terminal 1	41~62	Reserved
16	Multi-step frequency terminal 2	63	Simple PLC paused
17	Multi-step frequency terminal 3	64	Simple PLC disabled
18	Multi-step frequency terminal 4	65	Simple PLC stop memory clear
19	Accel/Decel time determinant 1	66	Start wobble frequency
20	Accel/Decel time determinant 2	67	Clear wobble frequency status
21	Accel/Decel disabled(ramp stop not inclusive)	68	Run prohibited
22	External fault input	69	DC braking in run
23	Fault reset (RESET)	70	Analog input curve switching
24	Pulse input (valid only for X6/DI)	71~99	Reserved
25	Motor 1/2 switchover		

0: No function

1: JOG forward

Jog forward through terminals. Jog frequency is set by b0-19, jog Accel time set by b2-10, and jog Decel time set by b2-11. Refer to C0-00 for enabled conditions on initial power up.

2: JOG reverse

Jog reverse through terminals. Jog FREQ is set by b0-19, jog Accel time by b2-10, and jog Decel time by b2-11. Refer to C0-00 for enabled conditions on initial power up.

3: Forward (FWD)

Terminals control forward run of the drive. Refer to C0-00 for enabled conditions on initial power up.

4: Reverse (REV)

Terminals control reverse run of the drive. Refer to C0-00 for enabled conditions on initial power up.

5: Three-wire control

There are two-wire control and three-wire control about Forward (FWD) and reverse (REV). In case of three-wire control is enabled, "three-wire control" terminal is activated. For details, refer to C0-19 (FWD/REV terminal control mode).

6: Run suspended

When "run suspended" terminal is enabled during the running, the drive will block the output and perform zero-frequency run. Once "run suspended" terminal becomes disabled, the drive restores the run.

7: External stop

No matter which type of b1-00 is set to, the drive will stop by enabled "external stop" terminal, in the manner of stop mode.

8: Emergency stop

When "emergency shutdown" is enabled, the drive will stop in accordance with Decel time set by b2-09. Please set b2-09 to an appropriate value so as to minimize the Decel time for emergency stop.

9: Stop command + DC brake

The drive performs ramp-down stop when "stop command+ DC brake" terminal is enabled. It will perform DC brake when output frequency attains brake start frequency. Brake start frequency and brake current are set by b1-14 and b1-15. Brake time is determined by the maximum of b1-16 and the lasting time of this terminal.

10: DC brake stop

The drive performs "ramp to stop + DC brake" (same as b1-13 is set to 2) when "DC brake stop" is enabled, in the manner set by b1-14, b1-15 and b1-16.

11: Coast to stop

When "coast to stop" terminal is enabled, the drive will immediately cut off its output and the motor will coast to stop.

12: Terminal UP**13: Terminal DOWN**

Terminals are used to increase and decrease the set frequency. The set frequency will be increased and decreased when "digital setting + terminal UP/DOWN adjustment" is enabled. The adjustment "step size" is set by C0-18. Refer to C0-17 for Terminal UP/DOWN frequency adjustment treatment.

14: Clear UP/DOWN (including \wedge/\vee key) adjustment

When frequency setting is "digital setting + terminal UP/DOWN adjustment" or "digital setting + control panel \wedge/\vee adjustment", this enabled terminal will clear the adjusted value via terminals UP/DOWN and keys \wedge/\vee , to digital set value b0-02 or b0-04.

15: Multi-step frequency terminal 1**16: Multi-step frequency terminal 2**

17: Multi-step frequency terminal 3

18: Multi-step frequency terminal 4

16-step frequency can be attained via combination of multi-step frequency terminals 1~4, as shown in Table 6-7:

Table 6-7

Multi-step frequency terminal 4	Multi-step frequency terminal 3	Multi-step frequency terminal 2	Multi-step frequency terminal 1	Frequency setting
OFF	OFF	OFF	OFF	Multi-step frequency 0 (F1-00)
OFF	OFF	OFF	ON	Multi-step frequency 1 (F1-01)
OFF	OFF	ON	OFF	Multi-step frequency 2 (F1-04)
OFF	OFF	ON	ON	Multi-step frequency 3 (F1-05)
OFF	ON	OFF	OFF	Multi-step frequency 4 (F1-06)
OFF	ON	OFF	ON	Multi-step frequency 5 (F1-07)
OFF	ON	ON	OFF	Multi-step frequency 6 (F1-08)
OFF	ON	ON	ON	Multi-step frequency 7 (F1-09)
ON	OFF	OFF	OFF	Multi-step frequency 8 (F1-10)
ON	OFF	OFF	ON	Multi-step frequency 9 (F1-11)
ON	OFF	ON	OFF	Multi-step frequency 10 (F1-12)
ON	OFF	ON	ON	Multi-step frequency 11 (F1-13)
ON	ON	OFF	OFF	Multi-step frequency 12 (F1-14)
ON	ON	OFF	ON	Multi-step frequency 13 (F1-15)
ON	ON	ON	OFF	Multi-step frequency 14 (F1-16)
ON	ON	ON	ON	Multi-step frequency 15 (F1-17)

19: Accel/Decel time determinant 1

20: Accel/Decel time determinant 2

Accel/Decel time determinant 1~2 can realize at most 4 Accel/Decel time settings through combination of different statuses as shown in Table 6-8. Accel/Decel time can be switched via different combinations during run.

Table 6-8

Accel/Decel time determinant 2	Accel/Decel time determinant 1	Accel/Decel time
OFF	OFF	Accel/Decel time 1(b2-01, b2-02)
OFF	ON	Accel/Decel time 2(b2-03, b2-04)
ON	OFF	Accel/Decel time 3(b2-05, b2-06)
ON	ON	Accel/Decel time 4(b2-07, b2-08)

 **ATTENTION:**

The selection of Accel/Decel time 1~4 is not determined by digital input terminals when the drive is running under simple PLC. See parameter Group F2 for details. When broken-line Accel/Decel is enabled, Accel/Decel time is automatically switched to Accel/Decel time 1 and 2 according to switching frequency (b2-13 and b2-14). In this case, Accel/Decel time determinant terminals are disabled.

21: Accel/Decel disabled (ramp stop not inclusive)

When "Accel/Decel disabled" terminal is enabled, the drive maintains the present output frequency and no longer responds to the change of frequency setting. But it will still perform ramp-down stop when receiving stop command. This terminal is disabled during normal ramp-down stop.

22: External fault input

This terminal is used to input the fault signal of external equipment, making the drive to perform fault monitoring and protection. When external fault signal is received, the drive shall display "PEr" and stop running.

23: Fault reset (RESET)

When the drive fault occurs, this enabled terminal will reset the fault. This function is the same with RESET key on control panel.

24: Pulse input (valid only for X6/DI)

This is valid only for digital input terminal X6/DI. This terminal receives pulse signal as frequency setting. Refer to C2-24~C2-27 for the relationship between pulse signal and frequency setting.

When pulse input is selected as the frequency setting, X6/DI terminal must be set to "pulse input" (C0-06 is set to 24).

25: Motor 1/2 switchover

The loaded motor can be selected via this terminal as shown in Table 6-9:

Table 6-9

A0-08	Motor 1/2 switchover terminal	Loaded motor
0	OFF	Motor 1
0	ON	Motor 2
1	OFF	Motor 2
1	ON	Motor 1

Set parameters of motor 1 in parameter groups d0~d2, and set parameters of motor 2 in groups d3~d5.

26: Reserved

27: Run command switched to control panel control

This terminal should be enabled by trigger edge. When this terminal status is switched from OFF to ON, run command will be switched to control panel control.

28: Run command switched to terminal control

This terminal should be enabled by trigger edge. When this terminal status is switched from OFF to ON, run command will be switched to terminal control.

29: Run command switched to communication control

This terminal should be enabled by trigger edge. When this terminal is switched from OFF to ON, run command will be switched to communication control.

30: Frequency set mode shift

When b0-00 is set to 2, 3 and 4, switch during various frequency set mode can be performed via "frequency set mode shift" terminal.

When b0-00 is set to 2, this terminal shall shift between master frequency setting and auxiliary frequency setting.

When b0-00 is set to 3, this terminal shall shift between master frequency setting, and master & auxiliary computation result.

When b0-00 is set to 4, this terminal shall shift between auxiliary frequency setting, and master & auxiliary computation result.

31: Master frequency setting switched to digital setting b0-02

When this terminal is disabled, b0-01 determines master frequency setting. When it is enabled, master frequency setting is forcibly switched to the value of b0-02.

 **ATTENTION:**

This terminal is disabled when the binding of run command and frequency setting is set by b1-01.

32: Auxiliary frequency setting switched to digital setting b0-04

When this terminal is enabled, b0-03 determines auxiliary frequency setting. When it is enabled, auxiliary frequency setting is forcibly switched to the value of b0-04.

33: PID adjustment direction

The combination of this terminal and value of F0-04 (PID positive and negative adjustment), can determine the positive or negative characteristics of PID adjustment.

Table 6-10

F0-04	PID adjustment direction terminal	Adjustment characteristic
0	OFF	Positive action
0	ON	Negative action
1	OFF	Negative action
1	ON	Positive action

34: PID paused

When this terminal is enabled, PID adjustment is paused, and the drive will maintain current output frequency. After this terminal becomes disabled, PID adjustment recovers.

35: PID integration paused

When this terminal is enabled, PID integrator stops its integration, and the current value is maintained. After this terminal becomes disabled, PID restores its integration.

36: PID parameter switch

When F0-14 (PID parameter switch) is set to "2: switched by terminal", this terminal could be used to realize the switching between two groups of PID parameters. When this terminal is enabled, PID parameters are Kp1 and Ti1, Td1 which are determined by F0-08~F0-10. When this terminal is disabled, PID parameters are Kp2, Ti2 and Td2 which are determined by F0-11~F0-13.

37: Count input

The maximum frequency at count pulse input terminal is 200Hz, and the count value can be memorized in case of power loss. With the setting of F3-12 (set count value) and F3-13 (designated count value), this terminal can control digital output "set count value attained" and "designated count value attained".

38: Count clear

Used with "count input" terminal, to clear pulse count value.

39: Length count

It is used for fixed-length control, and only takes effect on digital input terminal X6/DI. The length is calculated via pulse input. Please refer to specification of parameters F3-08~F3-11 for details. When the length is attained, digital output terminal "length attained" shall output effective signal. The current length value will be memorized on power loss.

40: Length clear

Used with "length count" terminal, to clear the length calculated.

41~62: Reserved**63: Simple PLC paused**

When simple PLC is running and this terminal is enabled, the current PLC status (run time and step) will be memorized, and the drive will run at 0Hz. When this terminal is disabled, the drive restores its running from the memorized moment.

64: Simple PLC disabled

When simple PLC is running, and this terminal is enabled. The status of PLC will be cleared and the output frequency is 0Hz. When this terminal is disabled again, the drive resumes PLC running from step 0.

65: Simple PLC stop memory clear

Under simple PLC running, if this terminal is enabled in stop status, the memorized information of PLC running step, running time and running frequency will be all cleared. Refer to parameter Group F2 for more information.

66: Start wobble frequency

This terminal takes effect only when F3-00 is set to "1: wobble frequency function enabled" and F3-01 ones place is set to "started through terminal". When this terminal is disabled, the drive runs at present frequency setting. When this terminal is enabled, the drive would activate wobble-frequency running immediately. Refer to Group F3 for details of wobble frequency.

67: Clear wobble frequency status

When the drive is running at wobble frequency, if this terminal is enabled, the memorized wobble frequency status will be cleared, no matter which wobble frequency start method (automatic/ via terminal) is taken. When this terminal is disabled, wobble frequency would resume. Refer to Group F3 for information of wobble frequency.

68: Run prohibited

When this terminal is enabled, the drive will coast to stop if it's running, and will prohibit start running if it's in a standby state. This terminal mainly applies to the situation where safety interlocking is required. Only after this terminal becomes disabled, the drive can be restarted.

69: DC brake in run

When this terminal is enabled, the drive will immediately fall into DC brake. After the terminal becomes disabled, the drive will be restored to normal state and ramp up to the frequency setting with the set ramp up time.

 ATTENTION:

When this terminal is enabled, output frequency does not need to decelerate to braking start frequency, but will directly inject DC whose value is set by b1-15.

70: Analog input curve switching

When C2-00 is set to 3: curve 2 is switching with curve 3, analog input curve can be

switched through this terminal. Analog curve 2 is selected when the terminal is OFF; analog curve 3 is selected when it's ON

71~99: Reserved

C0-11	Filtering time of digital input terminal	Range: 0.000s~1.000s	Factory default: 0.010s
-------	--	----------------------	-------------------------

Sets the filtering time of X1~X6 (when X6 is used as ordinary low-speed terminal), EX, AI1, AI2 and EAI (when used as digital input terminal). Interference immunity of digital input terminals can be improved by appropriate filtering time. However, the response time of digital input terminal will become slower when filtering time is increased.

ATTENTION:

This filtering time takes no effect on X6/DI when X6/DI terminal is used as DI high-speed input terminal, while the filtering time of DI is determined by parameter C2-28.

C0-12	Delay time of terminal X1	Range: 0.0s~3600.0s	Factory default: 0.0s
C0-13	Delay time of terminal X2	Range: 0.0s~3600.0s	Factory default: 0.0s

The delayed response time of digital input terminals X1 and X2 is set by these two parameters.

ATTENTION:

Terminal delay time C0-12 and C0-13 can be set with filtering time C0-11 at the same time. The drive will respond after the signals via X1 and X2 go through filtering time, and then delay time. Terminals X3~X6 and EX have no delay-time function.

C0-14	Digital input terminal enabled status setting 1	Range: 0000~1111	Factory default: 0000
-------	---	------------------	-----------------------

- ◆ Ones place: X1
- 0: Positive logic; ON when current flows through
- 1: Negative logic; ON when no current flows through
- ◆ Tens place: X2 (same as X1)
- ◆ Hundreds place: X3 (same as X1)
- ◆ Thousands place: X4 (same as X1)

C0-15	Digital input terminal enabled status setting 2	Range: 0000~1111	Factory default: 0000
-------	---	------------------	-----------------------

- ◆ Ones place: X5
- 0: Positive logic; ON when current flows through
- 1: Negative logic; ON when no current flows through
- ◆ Tens place: X6 (same as X5)

- ◆ Hundreds place: EX (on IO option board; same as X5)
- ◆ Thousands place: reserved

C0-16	Digital input terminal enabled status setting 3	Range: 0000~1111	Factory default: 0000
-------	---	------------------	-----------------------

This parameter sets the enabled condition of AI1, AI2 and EAI as digital input terminal (need to be defined by C0-08~C0-10).

- ◆ Ones place: AI1
- 0: Positive logic: < 3V, ON; > 7V, OFF
- 1: Negative logic: < 3V, OFF; > 7V, ON
- ◆ Tens place: AI2 (same as AI1)
- ◆ Hundreds place: EAI (on IO option board; same as AI1)
- ◆ Thousands place: reserved

ATTENTION:

When AI1, AI2, EAI are used as analog input terminals, do NOT use them as digital input terminals, thus C0-08~C0-10 shall be set to 0.

C0-17	Terminal UP/DOWN frequency adjustment action	Range: 0000~1111	Factory default: 0000
-------	--	------------------	-----------------------

- ◆ Ones place: at stop
- 0: Cleared
- Terminal UP/DOWN frequency adjustment value is cleared when the drive stops.
- 1: Maintained
- Terminal UP/DOWN frequency adjustment value is maintained when the drive stops.
- ◆ Tens place: on power loss
- 0: Cleared
- Terminal UP/DOWN frequency adjustment value is cleared in case of power loss.
- 1: Maintained
- Terminal UP/DOWN frequency adjustment value is saved in case of power loss.
- ◆ Hundreds place: integral function
- 0: No integral function
- Adjustment step size is kept constant during terminal UP/DOWN adjustment, in compliance with C0-18.
- 1: Integral function enabled
- When frequency is adjusted through terminal UP/DOWN, initial step size is set by C0-18. With the effective lasting time of the terminals, adjustment step size will increase gradually.
- ◆ Thousands place: run direction
- 0: Changing run direction prohibited
- When the frequency is decreased to 0Hz via terminal UP/DOWN, the drive will run at 0Hz and won't change its run direction.

1: Changing run direction allowed

When the frequency is decreased to 0Hz via terminal UP/DOWN, the drive will change its run direction if this decrease is continued.

C0-18	Terminal UP/DOWN frequency change step size	Range: 0.00Hz/s~100.00Hz/s	Factory default: 0.03Hz/s
-------	---	-------------------------------	------------------------------

When frequency setting is "digital setting + terminal UP/DOWN adjustment", this parameter is used to set the step size of frequency adjustment UP/DOWN. The step size is defined as frequency change per second, and the smallest step size is 0.01 Hz/s.

C0-19	FWD/REV terminal control mode	Range: 0~3	Factory default: 0
-------	-------------------------------	------------	-----------------------

There are four different methods when run command is determined by FED/REV terminal. This terminal control mode takes no effect on JOG.

0: Two-wire mode 1

FWD terminal inputs forward run command, while REV terminal inputs reverse run command.

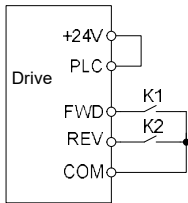

Fig. 6-17

Table 6-11

FWD	REV	Run command
OFF	OFF	Stop
OFF	ON	Reverse
ON	OFF	Forward
ON	ON	Stop

1: Two-wire mode 2

FWD terminal inputs run command, while REV terminal inputs run direction.

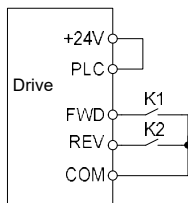

Fig. 6-18

Table 6-12

FWD	REV	Running command
OFF	OFF	Stop
OFF	ON	Stop
ON	OFF	Forward
ON	ON	Reverse

2: Three-wire mode 1

FWD terminal controls forward run of the drive, REV terminal controls reverse run, and digital input terminal "three-wire run" controls the stop. Input signals of all these three terminals take effect when trigger edge is detected.

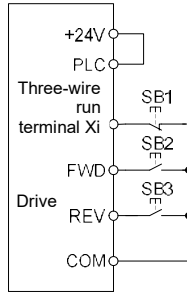

Fig. 6-19 Three-wire mode 1

SB1 is a stop button, by pressing which the drive will stop;

SB2 is a FORWARD button, by pressing which forward run will be activated;

SB3 is a REVERSE button, by pressing which reverse run will be activated.

Xi is a digital input terminal. In this case, it is necessary to define the function of corresponding terminal as "three-wire run" terminal.

3: Three-wire mode 2

FWD terminal controls the run, while run direction is determined by REV terminal. Digital input terminal "three-wire run" controls the stop.

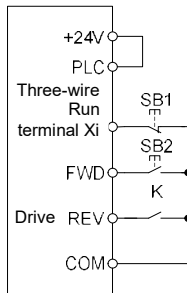

Fig. 6-20 Three-wire mode 2

SB1 is a stop button, by pressing which the drive will stop;

SB2 is a RUN button, by pressing which the drive will run. When switch K is open, run is forward, while when it is closed, run direction is reverse.

Xi is a digital input terminal. In this case, it is necessary to define the function of corresponding terminal as "three-wire run" terminal.

C0-20	Option of virtual input terminal	Range: 000~77F	Factory default: 000
-------	----------------------------------	----------------	----------------------

This parameter is a 10-bit binary numeral. The terminals that correspond respectively to bit10 (the highest bit of binary system) through bit0 (the lowest bit of binary system) are as follows:

Table 6-13

Hundreds place			Tens place				Ones place			
bit10	bit9	bit8	bit7	bit6	bit5	bit4	bit3	bit2	bit1	bit0
EIA	AI2	AI1	Rev d	EX	X6	X5	X4	X3	X2	X1

◆ Ones place: bit0~bit3 : X1~X4

0: Actual terminal takes effect

1: Virtual terminal takes effect

◆ Tens: bit4~bit6 : X5, X6, EX (same as ones place)

◆ Hundreds place: bit8~bit10 : AI1, AI2, EAI (same as ones place)

Virtual terminals simulate actual terminals via communication. Each bit represents one terminal. When selecting virtual terminal, corresponding bit should be set to 1 in C0-20. Under this circumstance the actual terminal is invalid.

C0-21	Enabled condition of run command terminal after fault reset (RESET)	Range: 0~1	Factory default: 0
-------	---	------------	--------------------

This parameter only takes effect on run command terminals, i.e. digital input terminal set as 1~4 (JOG forward/reverse, run forward/reverse. See table 6-6), and only works for the run after fault reset.

0: Trigger edge detected + ON detected

After the fault reset, the drive will start to run when an electric level jump from OFF to ON is detected and ON signal are maintained.

1: ON detected

The drive will run automatically if ON signal from run command terminal is detected. When this parameter value is set to 1, please make sure the status of run command terminals before fault reset operation. Failure to comply may result in equipment damage and/or personal injury.

Group C1 Digital Output

C1-00	Y1 output function	Range: 0~99	Factory default: 0
C1-01	Y2/DO output function (when used as Y2)	Range: 0~99	Factory default: 0

C1-02	Control board relay output function	Range: 0~99	Factory default: 14
C1-03	Option board relay output function	Range: 0~99	Factory default: 15

Define the functions of digital output terminals Y1 & Y2, control board relay and option board relay. When used as high-speed pulse output, Y2/DO terminal's function are not set in C1-01 but in C3-02. Output terminal function selections are as follows:

Table 6-14

Value	Function	Value	Function
0	No output	17	Drive overheated alarm
1	Drive undervoltage	18	Zero-current detection
2	Drive run preparation completed	19	X1
3	Drive is running	20	X2
4	Drive running at 0Hz (no output at stop)	21	Motor 1/2 indication
5	Drive running at 0Hz (output at stop)	22	Set count value attained
6	Run direction	23	Designated count value attained
7	Frequency attained	24	Length attained
8	Upper limit frequency attained	25	Consecutive run time attained
9	Lower limit frequency attained	26	Accumulative run time attained
10	Frequency detection FDT1	27	Brake control
11	Frequency detection FDT2	28~29	Reserved
12	Reserved	30	PLC step completed
13	Torque restricted	31	PLC cycle completed
14	Fault output	32	Wobble frequency attains to upper or lower limit frequency
15	Alarm output	33	Frequency attains to upper/lower limit frequency
16	Drive (motor) overloaded alarm	34	Frequency attains target-frequency set by C2-29

0: No output

Output terminal is disabled, and there is no output.

1: Drive undervoltage

When DC bus voltage is lower than the level of undervoltage, it outputs ON signal and LED control panel displays "LoU".

2: Drive run preparation completed

The output of ON signal indicates that the drive is free of fault. Under this circumstance, the drive is ready to accept run command.

3: Drive is running

The output is ON when the drive is running, and output is OFF when drive stopped.

4: Drive running at 0Hz (no output at stop)

When running at 0Hz, this corresponding terminal outputs ON signal. No ON signal will be output at stop.

5: Drive running at 0Hz (output at stop)

Outputs ON signal when running at 0Hz, and also outputs ON signal at stop.

6: Run direction

Outputs OFF signal under forward run and outputs ON signal under reverse run.

7: Frequency attained

When the deviation of output frequency from set frequency is less than the value of C1-14 (Detective width of frequency attained), outputs ON.

8: Upper limit frequency attained

When output frequency attains b0-09 (upper limit frequency), outputs ON.

9: Lower limit frequency attained

When output frequency attains b0-10 (lower limit frequency), outputs ON.

10: Frequency detection FDT1

Terminal outputs ON signal when output frequency exceeds C1-10 (FDT1 upper bound) and will not output OFF signal unless output frequency drops to below C1-11 (FDT1 lower bound).

11: Frequency detection FDT2

Terminal outputs ON when output frequency exceeds C1-12 (FDT2 upper bound) and will not output OFF unless output frequency drops to below C1-13 (FDT2 lower bound).

12: Reserved

13: Torque restricted

This takes effect only in the mode of sensor-less vector control. If output torque attains the limit value of drive torque or brake torque, terminal outputs ON.

14: Fault output

When the drive is in fault, it outputs ON.

15: Alarm output

When inverter gives an alarm, ON signal is output.

16: Drive (motor) overloaded alarm

In case drive output current exceeds E1-04 (overload alarm threshold) and its last time

exceeds E1-05 (overload alarm activated time that exceeding threshold), outputs ON. Refer to parameters E1-03~E1-05 for information with regard to drive (motor) overloaded alarm.

 **ATTENTION:**

In case of either drive is overloaded or motor is overloaded, it also will output ON.

17: Drive overheat alarm

When drive internally detected temperature exceeds E1-13 (Drive overheat alarm threshold), ON signal will be output.

18: Zero-current detection

When drive output current is less than the value of C1-15 (effective proportion of zero current detected) and the lasting time attains the value of C1-16 (Zero current detected time), ON signal will be output.

19: X1

Output the status of X1.

20: X2

Output the status of X2.

21: Motor 1/2 indication

When motor 1 is selected, outputs OFF. When motor 2 is selected, outputs ON.

22: Set count value attained

Refer to the specification of parameter F3-12.

23: Designated count value attained

Refer to the specification of parameter F3-13.

24: Length attained

Refer to the specification of parameters F3-08~F3-11.

25: Consecutive run time attained

When consecutive run time attains the value of E0-03, corresponding terminal outputs ON. Consecutive run time is cleared when stop.

26: Accumulative run time attained

When accumulative run time attains the value of E0-04, corresponding terminal outputs ON. Accumulative run time is maintained when stop.

27: Brake control

Refer to the specification of parameters E0-05~E0-11 for details.

28: Reserved

29: Reserved

30: PLC step completed

Upon the completion of current step of simple PLC running, ON signal with the width of 500ms will be output.

31: PLC cycle completed

Upon the completion of a cycle of simple PLC running, ON signal with a width of 500ms will be output.

32: Wobble frequency attains to upper or lower limit frequency

When drive output frequency attains upper limit frequency b0-09 or lower limit frequency b0-10 under wobble frequency running, ON signal will be output.

33: Upper/lower limit of set FREQ attained

34: Target FREQ attained (set by C2-29)

When the error of drive output frequency and C2-29 value is less than C1-14, target frequency is attained, this terminal output ON.

35~99: Reserved

C1-04	Y1 output time delay	Range: 0.0s~3600.0s	Factory default: 0.0s
C1-05	Y2 output time delay	Range: 0.0s~3600.0s	Factory default: 0.0s
C1-06	Control board relay output time delay	Range: 0.0s~3600.0s	Factory default: 0.0s
C1-07	Option board relay output time delay	Range: 0.0s~3600.0s	Factory default: 0.0s

These four parameters define the delay response time of digital output terminals Y1 & Y2, control board relay and option board relay.

ATTENTION:

When Y2/DO terminal is used as high-speed pulse output (set by C3-02), delay time set by C1-05 is disabled.

C1-08	Enabled state of digital output	Range: 0000~1111	Factory default: 0000
-------	---------------------------------	------------------	-----------------------

- ◆ Ones place: Y1
- 0: Positive logic; ON when current flows through
- 1: Negative logic; ON when no current flows through
- ◆ Tens place: Y2 (same as Y1)
- ◆ Hundreds place: control board relay output
- 0: Positive logic; ON when there is coil excitation
- 1: Negative logic; ON when there is no coil excitation
- ◆ Thousands place: option board relay output (same as control board relay)

Wiring diagram of digital output terminal is shown as Fig. 6-21:

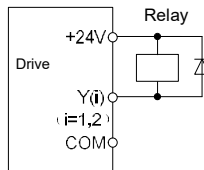

Fig. 6-21

C1-09	Detected object of FREQ detection (FDT)	Range: 00~11	Factory default: 00
-------	---	--------------	---------------------

◆ Ones place: FDT1 detected object

0: Set value of speed (frequency after Accel/Decel)

FDT1 output frequency is the set frequency after Accel/Decel.

1: Detected speed value

FDT1 output frequency is actually detected or identified frequency. If the drive is under V/f pattern, it should be output frequency.

◆ Tens place: FDT2 detected object

0: Set value of speed (frequency after Accel/Decel)

FDT2 output frequency is the set frequency after Accel/Decel.

1: Detected speed value

FDT2 output frequency is actually detected or identified frequency. If the drive is under V/f pattern, it should be output frequency.

C1-10	FDT1 upper value	Range: 0.00Hz~maximum FREQ	Factory default: 50.00Hz
C1-11	FDT1 lower value	Range: 0.00Hz~ maximum FREQ	Factory default: 49.00Hz
C1-12	FDT2 upper value	Range: 0.00Hz~ maximum FREQ	Factory default: 25.00Hz
C1-13	FDT2 lower value	Range: 0.00Hz~ maximum FREQ	Factory default: 24.00Hz

These parameters should be set with digital output terminals "FDT1" and "FDT2". Take FDT1 for example, the drive outputs ON signal when output frequency exceeds upper value of FDT1 and will not output OFF signal unless output frequency drops to below lower value of FDT1. Please set C1-10 to be larger to some certain extent than C1-11, avoiding status change frequently. See Fig. 6-22:

FDT2 performance figure is the same as FDT1.

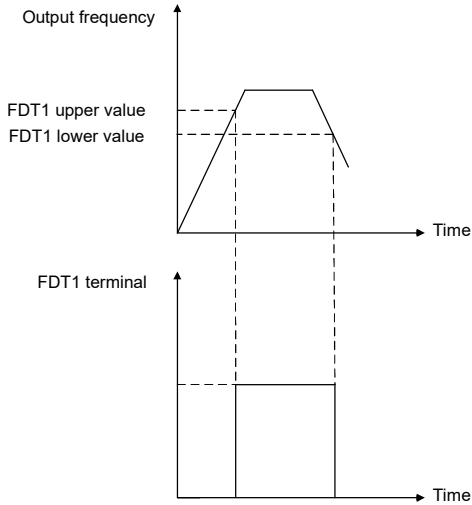

Fig. 6-22

C1-14	Detection width of frequency attained	Range: 0.00Hz~ maximum FREQ	Factory default: 2.50Hz
-------	---------------------------------------	--------------------------------	----------------------------

This parameter should be set with digital output terminal "frequency attained". When the difference between output frequency and set frequency is less than this value, terminal "frequency attained" outputs ON. See Fig. 6-23:

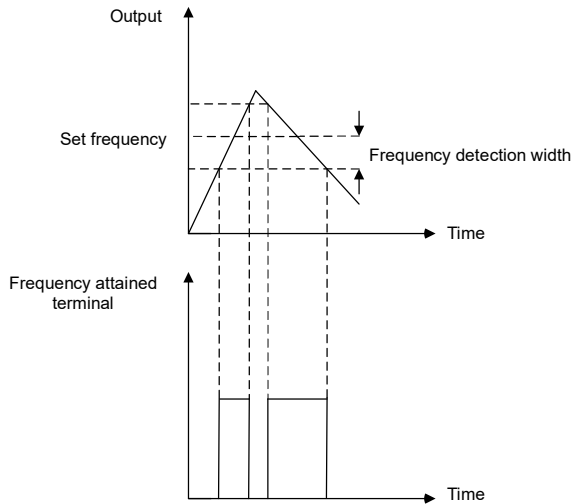

Fig. 6-23

C1-15	Zero current detection value	Range: 0.0%~50.0%	Factory default: 5.0%
C1-16	Zero current detection time	Range: 0.01s~50.00s	Factory default: 0.50s

The two parameters should be set with digital output terminal "zero current detection". When the drive output current is less than the value set by C1-15 and its lasting time attains the value of C1-16, terminal "zero current detection" outputs ON signal. See Fig. 6-24:

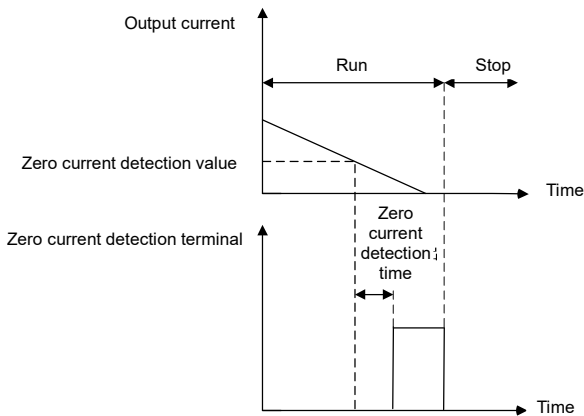

Fig. 6-24

Group C2 Analog and Pulse Input

C2-00	Analog input curve	Range: 0000~222	Factory default: 0210
-------	--------------------	-----------------	-----------------------

Curves of analog input AI1, AI2 and EAI are selected by this parameter.

◆ Ones place: AI1 input curve

0: Curve 1 (2 points)

Defined by C2-01~C2-04.

1: Curve 2 (4 points)

Defined by C2-05~C2-12.

2: Curve 3 (4 points)

Defined by C2-13~C2-20.

3: Curve 2 and curve 3 switchover

Curve 2 and curve 3 selection can be switched via terminal "analog input curve switchover".

When this terminal is deactivated, curve 2 takes effect, while when this terminal is activated, curve 3 will work.

- ◆ Tens place: AI2 input curve
Same as specification of AI1.
- ◆ Hundreds place: EAI input curve
Same as specification of AI1.
- ◆ Thousands place: reserved

C2-01	Curve 1 maximum input	Range: minimum input of curve 1 ~110.0%	Factory default: 100.0%
C2-02	Corresponding set value of curve 1 maximum input	Range: -100.0%~100.0%	Factory default: 100.0%
C2-03	Curve 1 minimum input	Range: -110.0% ~ curve 1 maximum input	Factory default: 0.0%
C2-04	Corresponding set value of curve 1 minimum input	Range: -100.0%~100.0%	Factory default: 0.0%

Curve 1 is defined by above-noted 4 parameters. Input values C2-01 and C2-03:

EAI on option board and AI1 can select 0~10V voltage input or 0~20mA current input by jumper.

If 0~10V is selected: 0V corresponds to 0%, while 10V corresponds to 100%.

If 0~20mA is selected: 0mA corresponds to 0%, while 20mA corresponds to 100%.

AI2 only supports -10V~10V input; for AI2, -10V corresponds to -100%, while 10V corresponds to 100%.

Corresponding set values C2-02 and C2-04:

When the corresponding set value is frequency: 100% is the maximum frequency, while -100% is the maximum negative frequency.

When the corresponding set value is current: 100% means 2 times the rated current of drive while "less than or equal to 0%" corresponds to zero current.

When corresponding set value is torque: 100% means 2 times the rated torque, while -100% means minus "2 times the rated torque".

When the corresponding set value is output voltage (e.g. the voltage setting in case of V/f separated pattern): 100% corresponds to rated voltage of motor. "Less than or equal to 0%" corresponds to 0V voltage.

Curve diagram is shown as below:

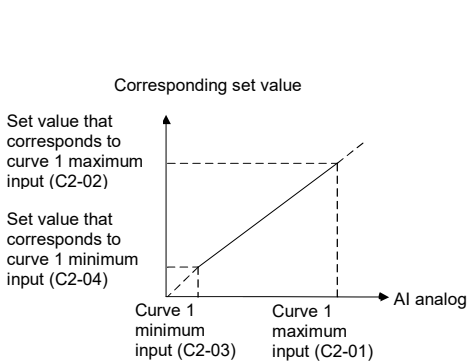

Fig. 6-25

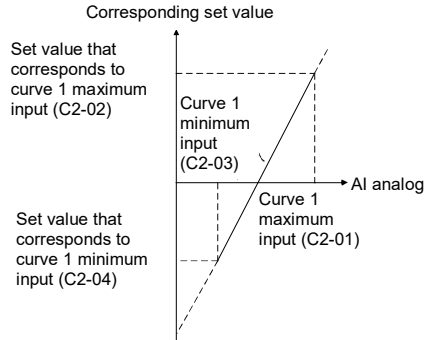

Fig. 6-26

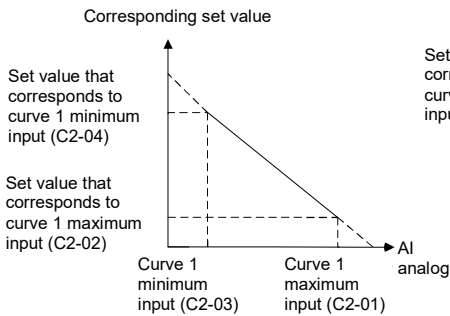

Fig. 6-27

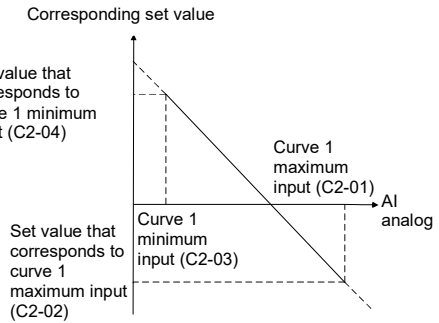

Fig. 6-28

C2-05	Curve 2 maximum input	Range: input of curve 2 inflection point A~110.0%	Factory default: 100.0%
C2-06	Set value corresponding to curve 2 maximum input	Range: -100.0%~100.0%	Factory default: 100.0%
C2-07	Input of curve 2 inflection point A	Input of curve 2 inflection point B ~ curve 2 maximum input	Factory default: 0.0%
C2-08	Set value corresponding to input of curve 2 inflection point A	Range: -100.0%~100.0%	Factory default: 0.0%

C2-09	Input of curve 2 inflection point B	Range: Curve 2 minimum input ~ Input of curve 2 inflection point A	Factory default: 0.0%
C2-10	Set value corresponding to input of curve 2 inflection point B	Range: -100.0%~100.0%	Factory default: 0.0%
C2-11	Curve 2 minimum input	Range: -110.0%~ input of curve 2 inflection point B	Factory default: -100.0%
C2-12	Set value corresponding to curve 2 minimum input	Range: -100.0%~100.0%	Factory default: -100.0%

Description of input value of curve 2: Voltage input:

- 1) With regard to AI1 and the EAI on option board, 0% corresponds to 0V or 0mA, while 100% corresponds to 10V or 20mA.
- 2) Regarding to AI2, -100% corresponds to -10V, while 100% corresponds to 10V.

Curve 2 is defined by C2-05~C2-12. The input of curve 2 and the definition of corresponding set value is the same as AI1. The difference is that curve 1 is a straight line while curve 2 is a broken line with two inflection points. Diagram of curve 2 is shown as below:

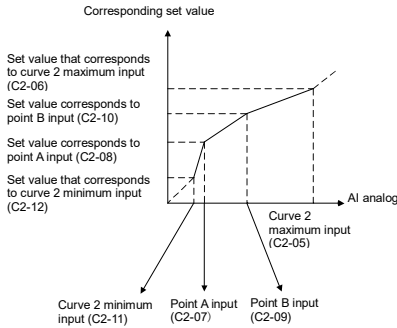

Fig. 6-29

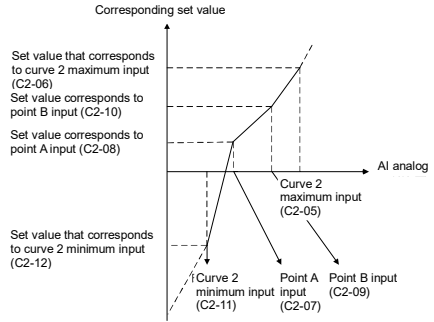

Fig. 6-30

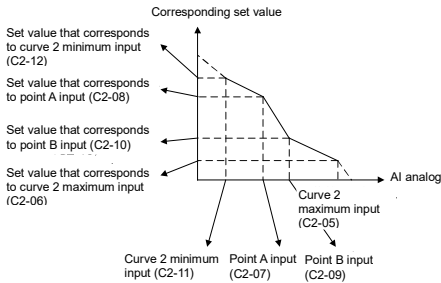

Fig. 6-31

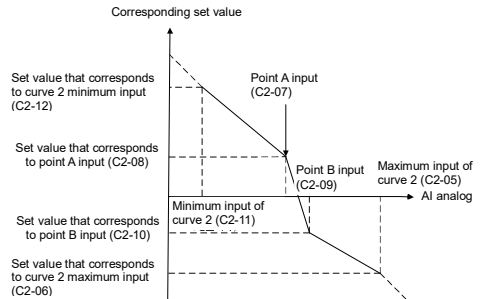

Fig. 6-32

C2-13	Curve 3 maximum input	Range: input of curve 3 inflection point A ~110.0%	Factory default: 100.0%
C2-14	Set value corresponding to curve 3 maximum input	Range: -100.0%~100.0%	Factory default: 100.0%
C2-15	Input of curve 3 inflection point A	Range: input of curve 3 inflection point B ~ curve 3 maximum input	Factory default: 0.0%
C2-16	Set value corresponding to input of curve 3 inflection point A	Range: -100.0%~100.0%	Factory default: 0.0%
C2-17	Input of curve 3 inflection point B	Range: curve 3 minimum input~ input of curve 3 inflection point A	Factory default: 0.0%
C2-18	Set value corresponding to input of curve 3 inflection point B	Range: -100.0%~100.0%	Factory default: 0.0%
C2-19	Curve 3 minimum input	Range: -110.0%~ input of curve 3 inflection point B	Factory default: 0.0%
C2-20	Set value corresponding to curve 3 minimum input	Range: -100.0%~100.0%	Factory default: 0.0%

Curve 3 is defined by C2-13~C2-20. The usage of curve 3 is the same as that of curve 2.

C2-21	AI1 terminal filtering time	Range: 0.000s~10.000s	Factory default: 0.1s
C2-22	AI2 terminal filtering time	Range: 0.000s~10.000s	Factory default: 0.1s
C2-23	EAI terminal filtering time	Range: 0.000s~10.000s	Factory default: 0.1s

C2-21~C2-23 define the filtering time of analog input terminals AI1, AI2 and EAI. Long filtering time results in strong immunity from interference but slow response, while short filtering time brings rapid response but weak immunity from interference.

C2-24	DI maximum input	Range: C2-26~50.0kHz	Factory default: 50.0kHz
C2-25	Set value corresponding to DI maximum input	Range: -100.0%~100.0%	Factory default: 100.0%
C2-26	DI minimum input	Range: 0.0kHz~C2-24	Factory default: 0.0kHz
C2-27	Set value corresponding to DI minimum input	Range: -100.0%~100.0%	Factory default: 0.0%

When digital input terminal X6/DI receives pulse signal as frequency setting, the relation

between input pulse signal and frequency setting is defined by curves set by C2-24~C2-27.

C2-24 and C2-26 represent the range of DI input pulse frequency. C2-25 and C2-27 are the set values of frequency that corresponds to DI input pulse frequency: 100% corresponds to positive maximum frequency while -100% corresponds to negative maximum frequency.

ATTENTION:

When pulse input is selected as the frequency setting, X6/DI terminal shall be set to "pulse input" function (C0-06 is set to 24).

C2-28	DI filtering time	Range: 0.000s~1.000s	Factory default: 0.001s
-------	-------------------	----------------------	----------------------------

Defines the filtering time of terminal X6/DI.

C2-29	Target FREQ	Range: 0.00Hz~upper limit frequency	Factory default: 0.0Hz
-------	-------------	-------------------------------------	---------------------------

This parameter should be used together with digital output terminal "Frequency attains target-frequency set by C2-29" (No.34 in table 6-14). When the error between drive output frequency and C2-29 value is less than the value of C1-14, terminal "Frequency attains target-frequency set by C2-29" outputs ON signal.

Group C3 Analog and Pulse Output

C3-00	AO1 output function	Range: 0~99	Factory default: 2
C3-01	EAO output function (on IO option board)	Range: 0~99	Factory default: 1
C3-02	Y2/DO output function (when used as DO)	Range: 0~99	Factory default: 0

AO1 and EAO are analog output terminals. When used as high-speed pulse output DO, Y2/DO terminal's functions are set in C3-02.

Voltage output or current output of AO1 and EAO can be selected through jumper switch. When S3 is switched to the position as shown in Fig. 6-33, AO1 output 0~10V. EAO analog output terminal is located at option board.

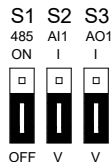

Fig. 6-33

Output range of DO pulse frequency is 0~C3-09 (maximum output pulse frequency). The ranges of corresponding digital output of AO1, EAO and DO are as shown in the table 6-15.

Table 6-15

Parameter value	Function	Range
0	No output	No output
1	Set FREQ	0~maximum frequency
2	Output frequency	0~maximum frequency
3	Output current	0~2 times the rated current of inverter
4	Output torque	0~2 times the rated torque
5	Output voltage	0~2 times the rated voltage of motor
6	Output power	0~ 2 times the rated power
7	Bus voltage	0~1000V
8	Reserved	Reserved
9	Torque current	0~2 times the rated current of motor
10	Magnetic flux current	0~ 2 times the rated current of motor
11	AI1	0~10V/0~20mA
12	AI2	-10V~10V
13	EAI	0~10V/0~20mA
14	Reserved	Reserved
15	DI	0~50kHz
16	Communication input percentage	0~65535
17	Output frequency before compensation	0~maximum frequency
18	Output current (relative to motor rated current)	0~2 times of rated output current of the motor
19	Output torque (direction hinted)	-2 times rated torque~2 times rated torque
20	Set torque (direction hinted)	-2 times rated torque~2 times rated torque

C3-03	AO1 offset	Range: -100.0%~100.0%	Factory default: 0.0%
C3-04	AO1 gain	Range: -2.000~2.000	Factory default: 1.000

When users need to change AO1 measuring range or correct the meter error, it can be realized by setting of C3-03 and C3-04. When using factory default set: 0~10V (or 0~20mA) of AO1 corresponds to "0~maximum". See table 6-15 for details. By expressing standard output of AO1

as x , the adjusted AO1 output as y , the gain as k , and the offset as b (100% of offset corresponds to 10V or 20mA), there is the equation: $y=kx+b$

Example:

Set C3-00 to 2: output frequency. Standard AO1 output: AO1 outputs 0V when output frequency is 0, and outputs 10V when output frequency is maximum frequency. If AO1 is requested to output 2V when output frequency is 0Hz, and to output 8V when output frequency is the maximum frequency.

There is: $2=k \times 0 + b$; $8=k \times 10 + b$. Through these two equations, we obtain: $k = 0.6$, $b = 2V$, i.e. C3-03 is set to 20.0% while C3-04 is set to 0.600.

Additional examples are shown as below:

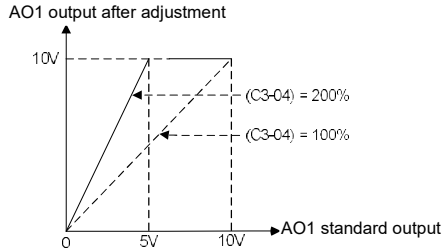

Fig. 6-34 Influence of AO1 gain against output

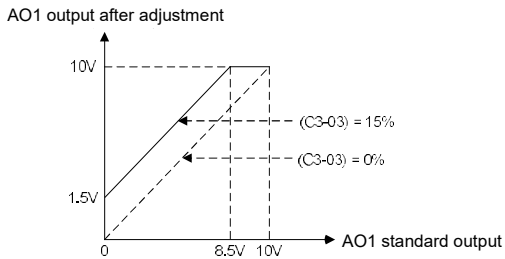

Fig. 6-35 Influence of AO1 offset against output

C3-05	AO1 filtering time	Range: 0.0s~10.0s	Factory default: 0.0s
-------	--------------------	-------------------	--------------------------

Defines output filtering time of AO1 terminal.

C3-06	EAO offset	Range: -100.0%~100.0%	Factory default: 0.0%
-------	------------	-----------------------	--------------------------

C3-07	EAO gain	Range: -2.000~2.000	Factory default: 1.000
C3-08	EAO filtering time	Range: 0.0s~10.0s	Factory default: 0.0s

Adjustment method of EAO output curve is the same as AO1.

C3-09	DO maximum output pulse frequency	Range: 0.1kHz~50.0kHz	Factory default: 50.0kHz
-------	-----------------------------------	-----------------------	--------------------------

This parameter sets the maximum output frequency when Y2/DO terminal is selected as high-speed pulse output.

C3-10	DO output center point	Range: 0~2	Factory default: 0
-------	------------------------	------------	--------------------

There are three different center point modes when Y2/DO terminal is selected as high-speed pulse output.

0: No center point.

DO pulse frequency output range 0~ (C3-09) corresponds to "0~maximum", as shown in Fig. 6-36:

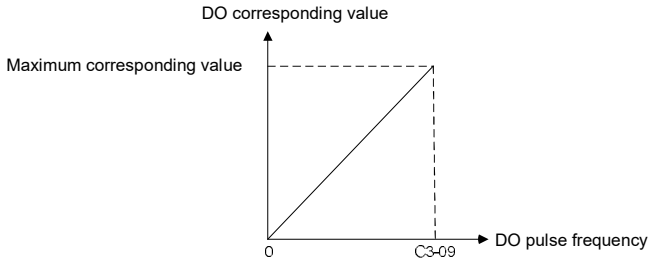

Fig. 6-36

1: Center point is (C3-09)/2, and the corresponding parameter value is positive when frequency is higher than center point. The value that corresponds to DO pulse frequency at center point is 0. DO pulse frequency C3-09 corresponds to the positive maximum value, while DO pulse frequency 0Hz corresponds to the negative maximum value. See Fig. 6-37:

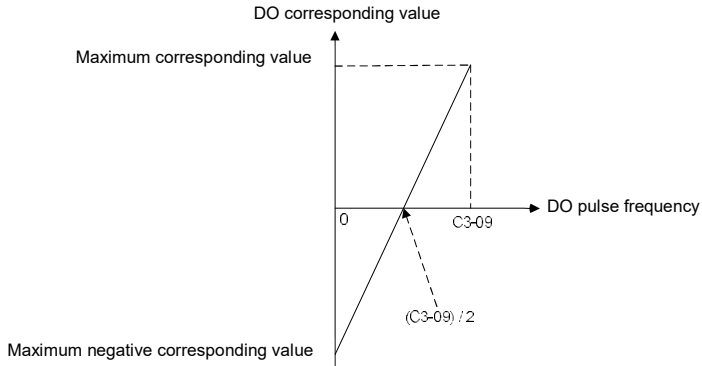

Fig. 6-37

2: Center point is $(C3-09)/2$, and the corresponding parameter value is positive when frequency is lower than center point. The value that corresponds to DO pulse frequency at center point is 0. When set to 0, DO pulse corresponds to the positive maximum value, while when set to C3-09, DO pulse frequency corresponds to the negative maximum value. See Fig. 6-38:

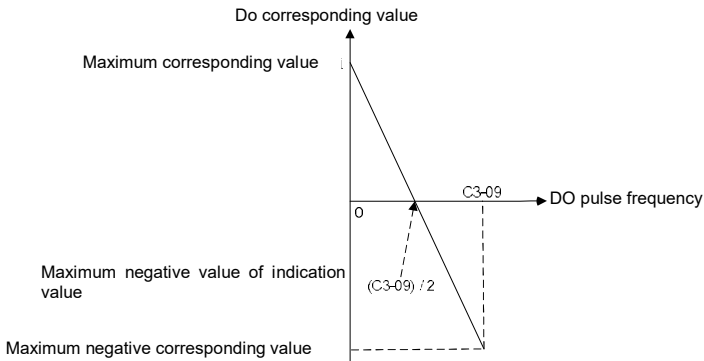

Fig. 6-38

C3-11	DO output filtering time	Range: 0.00s~10.00s	Factory default: 0.00s
-------	--------------------------	---------------------	---------------------------

Set the filtering time of DO high-speed pulse output. Filtering can change the changing rate of output pulse frequency. The longer the filtering time is, the lower the change rate of output pulse frequency would be.

Group C4 Automatic Correction of Analog Input

Parameter Group C4 is used to perform automatic correction of analog input channels, obtaining the gain and offset of corresponding channel automatically. They can automatically modify the measuring range of corresponding channel or correct meter error.

C4-00	Analog correction	Range: 0~3	Factory default: 0
-------	-------------------	------------	--------------------

0: No correction

No correction to any analog input.

1: Correct AI1

Automatically correct analog AI1.

2: Correct AI2

Automatically correct analog AI2.

3: Correct EAI

Automatically correct analog EAI.

C4-01	Sampling value of AI1 calibration point 1	Range: 0.00V~10.00V	Factory default: 1.00V
C4-02	Input value of AI1 calibration point 1	Range: 0.00V~10.00V	Factory default: 1.00V
C4-03	Sampling value of AI1 calibration point 2	Range: 0.00V~10.00V	Factory default: 9.00V
C4-04	Input value of AI1 calibration point 2	Range: 0.00V~10.00V	Factory default: 9.00V
C4-05	Sampling value of AI2 calibration point 1	Range: -10.00V~10.00V	Factory default: 1.00V
C4-06	Input value of AI2 calibration point 1	Range: -10.00V~10.00V	Factory default: 1.00V
C4-07	Sampling value of AI2 calibration point 2	Range: -10.00V~10.00V	Factory default: 9.00V
C4-08	Input value of AI2 calibration point 2	Range: -10.00V~10.00V	Factory default: 9.00V
C4-09	Sampling value of EAI calibration point 1	Range: 0.00V~10.00V	Factory default: 1.00V
C4-10	Input value of EAI calibration point 1	Range: 0.00V~10.00V	Factory default: 1.00V
C4-11	Sampling value of EAI calibration point 2	Range: 0.00V~10.00V	Factory default: 9.00V

C4-12	Input value of EAI calibration point 2	Range: 0.00V~10.00V	Factory default: 9.00V
-------	--	---------------------	------------------------

Take AI2 for example, automatic correction is as follows

- 1) Set C4-00 to 2 in stop status and press ENT key to confirm. In this way, AI2 is selected as correction channel.
- 2) Input a relatively low analog voltage (e.g. about 1V) via AI2 terminal, and input the theoretical value of this analog voltage by C4-06 after the stabilization of this voltage input, and then press ENT key to confirm.
- 3) Input a relatively high analog voltage (e.g. about 9V) via AI2 terminal, and input the theoretical value of this analog voltage by C4-08 after the stabilization of this voltage input, and then press ENT key to confirm.
- 4) Upon the successful correction, C4-00 parameter will be restored to zero.

 **ATTENTION:**

Set the theoretical value or actual value of analog voltage in C4-06 and C4-08. This value can be either the set value of analog output of peripheral equipment, or the actual voltage value of analog input measured by a multimeter or other instruments. C4-05 and C4-07 are the sampling values of analog input voltage. These values are for reference only. Do not write the value of C4-05 directly into C4-06, or write the value of C4-07 directly into C4-08.

Group d Motor and Control Parameters

Group d0 Parameters of Motor 1

When motor 1 is selected as current load motor, please set motor parameters in Group d0.

d0-00	Type of motor 1	Range: 0~2	Factory default: 1
-------	-----------------	------------	--------------------

- 0: Ordinary asyn. motor
- 1: Variable frequency asyn. motor
- 2: Synchronous motor

The major difference between ordinary motor and variable frequency motor lies in the handling of motor overload protection. Under low speed run, ordinary motor has poor heat dissipation, so motor overload protection shall be derated at low speed. Since fan-based heat dissipation of variable frequency motor is not affected by motor speed, low-speed overload protection is not necessarily derated. Therefore, please set d0-00 to 0 when driving ordinary asynchronous motor so as to protect the motor reliably.

d0-01	Power rating of motor 1	Range: 0.4kW~6553.5kW	Factory default: model dependent
d0-02	Rated voltage of motor 1	Range: 0V~480V	Factory default: 380V

d0-03	Rated current of motor 1	Range: 0.0A~6553.5A	Factory default: model dependent
d0-04	Rated frequency of motor 1	Range: 0.00Hz~upper limit frequency	Factory default: 50.00Hz
d0-05	Pole number of motor 1	Range: 1~80	Factory default: 4
d0-06	Rated speed of motor 1	Range: 0~65535 r/min	Factory default: model dependent

Above-noted motor parameters must be correctly set according to motor nameplate. Please select the motor that suits the power class of the drive, or the control performance of the drive will drop dramatically.

d0-07	Stator resistance R1 of asyn. motor 1	Range: 0.001Ω~65.535Ω	Factory default: model dependent
d0-08	Leakage inductance L1 of asyn. motor 1	Range: 0.1mH~6553.5mH	Factory default: model dependent
d0-09	Rotor resistance R2 of asyn. motor 1	Range: 0.001Ω~65.535Ω	Factory default: model dependent
d0-10	Mutual inductance L2 of asyn. motor 1	Range: 0.1mH~6553.5mH	Factory default: model dependent
d0-11	No-load current of asyn. motor 1	Range: 0.0A~6553.5A	Factory default: model dependent
d0-12	Flux weakening coeff 1 of asyn. motor 1	Range: 0.0000~1.0000	Factory default: model dependent
d0-13	Flux weakening coeff 2 of asyn. motor 1	Range: 0.0000~1.0000	Factory default: model dependent
d0-14	Flux weakening coeff 3 of asyn. motor 1	Range: 0.0000~1.0000	Factory default: model dependent

The drive needs above-noted parameters to control its matching asyn. motor. If the parameters of motor 1 is known, just write the actual value into d0-07~d0-14 correspondingly.

After the autotuning of motor 1, above-noted parameters are automatically updated and saved. Parameters d0-07~d0-09 are obtained through static autotuning, and parameters d0-07~d0-14 are obtained through rotary autotuning. If above-noted parameters are unknown and it is not allowed to perform motor autotuning, please input the parameters manually by referring to parameters of like motors.

If motor power rating d0-01 is changed, d0-02~d0-14 will be automatically restored to default setting of the standard motor.

d0-15	Stator resistance of syn. motor 1	Range: 0.001Ω~65.535Ω	Factory default: 0.500Ω
d0-16	D-axis inductance of syn. motor 1	Range: 0.01mH~655.35mH	Factory default: 9.00mH
d0-17	Q-axis inductance of syn. motor 1	Range: 0.01mH~655.35mH	Factory default: 9.00mH
d0-18	Back EMF voltage of syn. motor 1	Range: 0.0~1000.0V	Factory default: 380.0V

The drive needs above-noted parameters to control its matching syn. motor. If the parameters of motor 1 is known, just write the actual value into d0-15~d0-18 correspondingly.

After the autotuning of motor 1, above-noted parameters are automatically updated and saved. Parameters d0-15~d0-17 are obtained through static autotuning, and parameters d0-15~d0-18 are obtained through rotary autotuning. If above-noted parameters are unknown and it is not allowed to perform motor autotuning, please input the parameters manually by referring to parameters of like motors.

d0-19	Autotuning current of syn. motor 1	Range: 0.0%~100.0%, 100% is motor rated current	Factory default: 35.0%
d0-22	Autotuning of motor 1	Range: 0~5	Factory default: 0

Parameters for controlling the motor performance are automatically obtained through autotuning, and the result will be automatically saved upon the completion of autotuning. No matter it is asyn. motor or syn. motor, be sure to correctly input motor 1 parameters d0-01~d0-06 before autotuning.

0: No autotuning

1: Static autotuning of asyn. motor

Static autotuning applies to the cases where rotary autotuning cannot be favorably performed due to the fact that it is impossible to disengage the motor from its load. After d0-22 is set to 1 and confirmed, press the key RUN to start static autotuning. d0-22 will be restored to 0 upon the successful completion of autotuning. In this way, parameters d0-07~d0-09 are obtained.

2: Rotary autotuning of asyn. motor

To perform rotary autotuning, it is essential to disengage the motor from its load. Autotuning is prohibited when motor is loaded. After d0-22 is set to 2 and confirmed, press RUN to perform static autotuning, upon the completion of which, the motor would accelerate to a fixed frequency in the set ramp-up time, maintaining a period of time, and then stop by ramp down according to the set ramp down time. In this way, the autotuning comes to an end, and d0-22 will be restored to 0. Parameters d0-07~d0-14 have be obtained after the successful completion of rotary autotuning. To perform rotary autotuning, please set appropriate ramp-up and ramp-down time (i.e. Accel/Decel time. If overcurrent or overvoltage fault occurs during autotuning, please prolong Accel/Decel time accordingly.

3: Reserved

4: Static autotuning of syn. motor

Applies to parameter autotuning for syn. motor. After d0-22 is set to 4 and confirmed, press the key RUN to start static autotuning. d0-22 will be restored to 0 upon the successful completion of autotuning. In this way, parameters d0-15~d0-17 are obtained.

5: No-load rotary autotuning of syn. motor

Applies to parameter autotuning for syn. motor. After d0-22 is set to 5 and confirmed, press the key RUN to start rotary autotuning. d0-22 will be restored to 0 upon the successful completion of autotuning. In this way, parameters d0-15~d0-18 are obtained. d0-19 is autotuning current for rotary autotuning, if motor cannot run during rotary autotuning, this current can be properly increased.

ATTENTION:

Please make sure the motor is in a stationary state before the autotuning, or autotuning cannot be performed normally.

Control panel displays "TUNE" and RUN indicator light is on during autotuning. RUN indicator light is off upon the completion of autotuning.

Once autotuning fails, the fault code "tUN" shall be displayed.

d0-23	Overload protection of motor 1	Range: 0~2	Factory default: 1
-------	--------------------------------	------------	--------------------

Determine the overload protection of motor 1.

0: No protection

Once 0 is selected, it would be impossible to perform motor overload protection. Please take care.

1: Judged by motor current

Provide overload protection judged from output current and its lasting time. Overload protection detection time is set by d0-24.

2: Judged by temperature transducer

Input motor temperature sensor signal through analog input channel set by d0-25. The signal voltage is compared with the protection threshold set by d0-26. If it is higher than protection threshold, motor overheat fault "oH2" could be displayed.

d0-24	Overload protection detection time of motor 1	Range: 0.1min~15.0min	Factory default: 5.0min
-------	---	-----------------------	-------------------------

When d0-23 is set to "1: judged by motor current", overload protection time is determined by this parameter on the basis of the run current being 150% of motor rated current. An alarm of motor overload fault "oL2" shall be displayed once the lasting time exceeds this parameter value. Protection time when the run current is other value is automatically calculated according to inverse time lag characteristic curve. See Fig. 6-39.

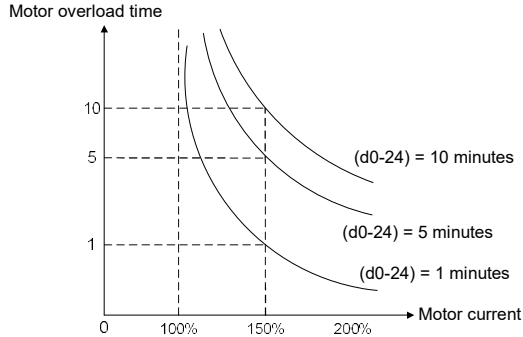

Fig. 6-39 Motor protection curve for ordinary motor running at 50Hz

Overload protection is performed for variable frequency motor according to the curve as shown in Fig. 6-39 at either high or low rotation speed. Due to the fact that fan-based heat dissipation of ordinary motors become poor at low speed, the protection is derated at low speed.

Example: when d0-24 is set to 10.0 minutes, and the motor is running at 10Hz input, motor overload fault "oL2" shall be displayed when the running current is 150% of the motor rated current with lasting time 4 minutes. See Fig. 6-40.

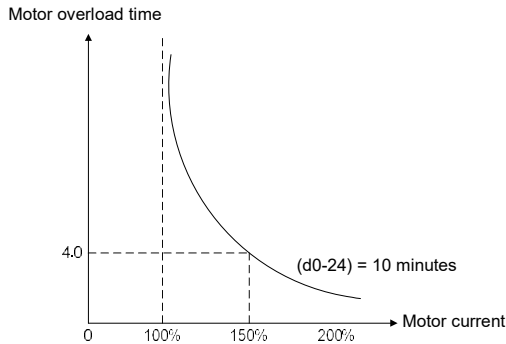

Fig. 6-40 Overload protection curve for ordinary motor running at 10Hz

d0-25	Temperature transducer signal input of motor 1	Range: 0~2	Factory default: 1
-------	--	------------	--------------------

- 0: AI1
- 1: AI2
- 2: EAI

When d0-23 is set to "2: judged by temperature transducer ", the analog signal input of temperature sensor of motor 1 is set by this parameter. The drive compares the signal input value via this analog channel with the thermal protection threshold set by d0-26. If it is bigger

than the threshold, the drive will immediately give an alarm of motor overheat fault "oH2". Protection through temperature sensor has no characteristic of inverse time lag curve.

d0-26	Thermal protection threshold of motor 1 temperature transducer	Range: 0.00V~10.00V	Factory default: 10.00V
-------	--	---------------------	-------------------------

This parameter works together with d0-25, and this parameter value, corresponding to motor 1 overheat protection point, needs to be calculated in accordance with the type of temperature sensor. Please consult Oxin Drive technical service engineer for this parameter value setting. When the input analog signal through the channel selected by d0-25 is bigger than this threshold, the drive will immediately trip with motor overeat fault "oH2".

d0-27	SW rotary speed track Kp	Range: 0.00~655.35	Factory default: 0.00
d0-28	SW rotary speed track Ki	Range: 0.00~655.35	Factory default: 2.00

Set as factory default.

Group d1 V/f Control Parameters of Motor 1

Set control parameters in Group d1 when motor 1 is selected as current load motor on which V/f control is performed.

d1-00	V/f curve setting	Range: 0~8	Factory default: 0
-------	-------------------	------------	--------------------

Set the relation between output voltage and output frequency of the drive when motor 1 is under V/f control.

0: Linear V/f

Applies to general constant-torque load. When drive output frequency is 0, output voltage will be 0, while when output frequency is rated frequency of motor, the output voltage would be rated voltage of motor.

1: Broken line V/f (determined by d1-01~d1-08)

Applies to spin drier, centrifuge, industrial washing machine and other special loads. When drive output frequency is 0, output voltage will be 0, while when output frequency is rated frequency of motor, the output voltage would be rated voltage of motor. What is different is this pattern can set 4 inflection points by d1-01~d1-08. See Fig. 6-41.

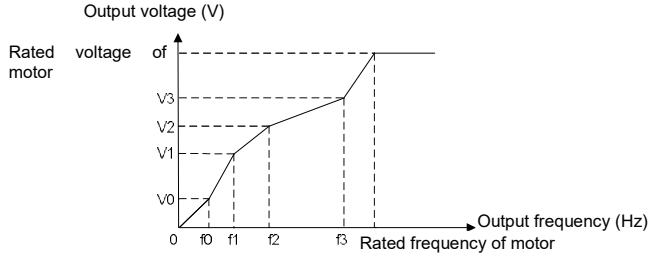

Fig. 6-41 User-defined various segments V/f curve

V0, V1, V2, V3 and f0, f1, f2 and f3 in the figure are voltage value and frequency value set by parameters d1-01~d1-08.

- 2: 1.2nd power
- 3: 1.4th power
- 4: 1.6th power
- 5: 1.8th power
- 6: 2.0th power

Parameter values 2~6 apply to torque-dropped loads such as fans and water pumps. See Fig. 6-42.

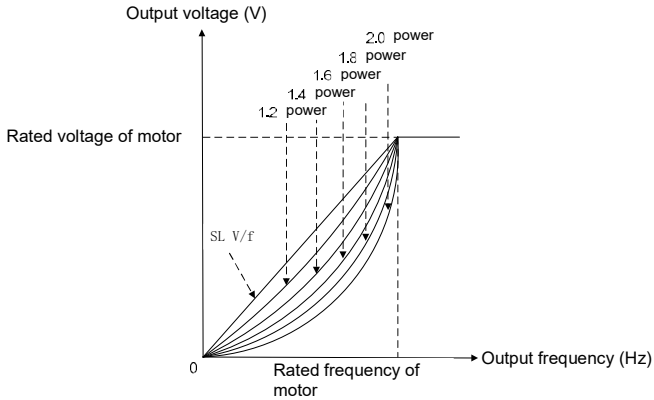

Fig. 6-42 1.2~2.0 power V/f curve

7: V/f separated pattern 1

Output frequency and output voltage can be set separately. Frequency is set by the method as stated in Group b0. Output voltage is set by d1-18. See d1-18 for details. This mode applies to variable-frequency power supply or torque motor control etc.

8: V/f separated pattern 2

Determine a certain voltage by linear V/f mode, and then multiply this voltage by the proportion set by d1-18 to obtain drive output voltage. See d1-18 for details.

d1-01	V/f frequency value f3	Range: 0.00Hz~rated frequency of motor	Factory default: 50.00Hz
d1-02	V/f voltage value V3	Range: 0.0%~100.0%	Factory default: 100.0%
d1-03	V/f frequency value f2	Range: d1-05~d1-01	Factory default: 0.00Hz
d1-04	V/f voltage value V2	Range: 0.0%~100.0%	Factory default: 0.0%
d1-05	V/f frequency value f1	Range: d1-07~d1-03	Factory default: 0.00Hz
d1-06	V/f voltage value V1	Range: 0.0%~100.0%	Factory default: 0.0%
d1-07	V/f frequency value f0	Range: 0.00Hz~d1-05	Factory default: 0.00Hz
d1-08	V/f voltage value V0	Range: 0.0%~100.0%	Factory default: 0.0%

d1-01~d1-08 is used for broken line V/f mode. Voltage value 100% corresponds to rated voltage of motor. Please suitably set the values of frequency and voltage at knees on the basis of characteristics of motor and load. Improper setting may rise output current even burn the motor.

d1-09	Torque boost	Range: 0.0%~30.0%	Factory default: 0.0%
-------	--------------	-------------------	-----------------------

Under V/f pattern, output voltage at low frequency can be compensated by this parameter, improving the torque output. 0.0% corresponds to automatic torque boost, and drive output voltage is automatically compensated via detection of load current. Automatic torque boost is valid only for linear V/f pattern.

100% of torque boost corresponds to rated voltage of motor. A non-zero value means the output voltage rises on the basis of V/f curve and this takes effect at parameter values 0~6 of d1-00. It is suggested this parameter value be gradually increased from zero until the starting requirement is met. Boost value is not suggested to be set to a relatively big one, as it is likely to bring about a bigger drive current and higher motor temperature.

Torque boost diagram is shown as Fig. 6-43:

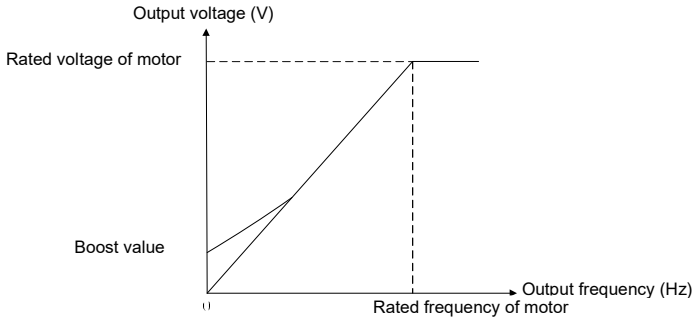

Fig. 6-43

d1-10	Slip compensation gain	Range: 0.0%~400.0%	Factory default: 100.0%
-------	------------------------	--------------------	----------------------------

Used under V/f control. When the motor is driving an electric-driven load, motor speed drops with the increase of load. When the motor is driving a power generating load, motor speed will increase with the increase of load. Appropriate slip compensation gain can maintain constant motor speed when the motor load is changing.

To ensure the performance of slip compensation gain, setting motor rated speed d0-06 is essential. The difference between d0-06 and the motor running speed without load is the rated slip. Through real-time detection of motor load, slip compensation automatically adjusts the drive output frequency on the basis of rated slip and motor load, reducing the impact of changing load on motor speed.

Gain adjustment method: please make the adjustment around 100%. When motor is driving an electric-driven load: if motor speed is relatively lower, the gain should be appropriately increased; if motor speed is relatively higher, reduce the gain appropriately. When motor is driving a power generating load: if motor speed is relatively lower, the gain should be decreased; if motor speed is relatively higher, increase the gain appropriately.

Diagram of slip compensation gain is shown as Fig. 6-44 and 6-45.

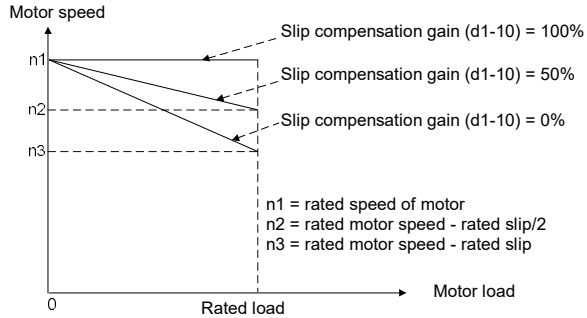

Fig. 6-44 Diagram of slip compensation on electric driven load

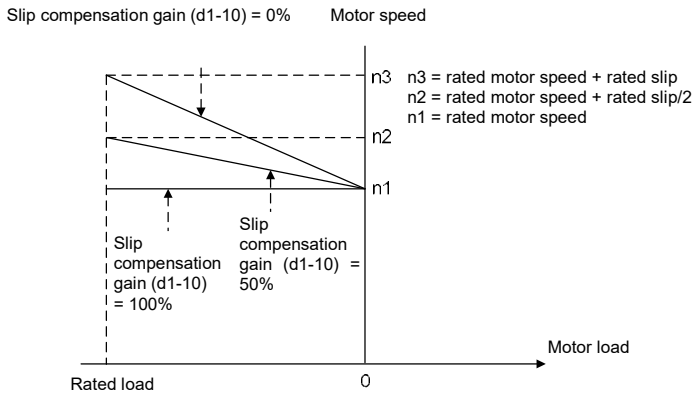

Fig. 6-45 Diagram of slip compensation on power generating load

d1-11	Droop control	Range: 0.00Hz~maximum frequency	Factory default: 0.00Hz
-------	---------------	---------------------------------	-------------------------

In case several drives drive one load, different drives may bear different proportion of the load. Through the setting of this parameter, the uniform load distribution on these drives could be attained.

The drive takes real-time detection of its load. Output frequency is automatically dropped according to the load and this parameter value, reducing itself borne load proportion. Parameter value of d1-11 corresponds to drop frequency with rated load.

d1-12	Current limitation mode	Range: 0~5	Factory default: 1
-------	-------------------------	------------	--------------------

- 0: Disabled
- 1: Set by d1-13
- 2: Set by AI1
- 3: Set by AI2
- 4: Set by EAI

Drive output current is limited by analog input in the range of " 0~200% x rated current of drive".

- 5: Set by X6/DI

Drive output current is limited by X6/DI pulse input in the range of "0~200% x rated current of drive".

When a non-zero value is set by d1-12, the current limitation is enabled. When output current rises dramatically because of sharp change of load, instant adjustment of output frequency will keep the output frequency below the set limitation. When the load is reduced, output frequency will recover promptly. If the setting speed or motor load change dramatically, this function can effectively reduce over-current fault.

When current limitation is enabled, the output frequency at constant speed may change at times and the Accel/Decel time may probably be automatically prolonged. Therefore, this function should not be used where output frequency or Accel/Decel time is not allowed to change.

d1-13	Digital setting of current limit value	Range: 20.0%~200.0%	Factory default: 160.0%
-------	--	---------------------	-------------------------

When d1-12 is set to "1: set by d1-13", the drive keeps output current less than this current limit value through instantaneous adjustment of output frequency. 100% current limit value corresponds to rated current of the drive. If this parameter value is set to a relatively big one, it will increase the chances of over-current. If this parameter value is set to a relatively small one, it will affect the loaded capability of the drive.

d1-14	Current limit coeff on flux weakening	Range: 0.001~1.000	Factory default: 0.500
-------	---------------------------------------	--------------------	------------------------

When the drive runs at the frequency higher than rated frequency of motor, Accel/Decel characteristic and output torque can be effectively improved by setting this parameter appropriately.

d1-15	Energy saving percentage	Range: 0%~40.0%	Factory default: 0.0%
-------	--------------------------	-----------------	-----------------------

During no-load or light-load application, load current is detected so as to appropriately reduce output voltage, reducing the copper loss and iron loss of motor with the purpose of energy saving. The larger the energy-saving percentage is, the better the energy-saving effect will be,

but the response will be slower. This parameter is applicable to loads such as fan and pump or light-load for a long time. Where rapid change is required, this parameter is suggested to be default set 0.0%.

d1-16	V/f oscillation suppression gain 1	Range: 0~3000	Factory default: 38
d1-17	V/f oscillation suppression gain 2	Range: 0~3000	Factory default: 0

Under V/f control, speed and current oscillation is likely to occur due to load vibration, and may lead to system failure even over current protection. This is particularly obvious during no-load or light-load applications. The appropriate setting of parameter values of d1-16 and d1-17 would effectively suppress speed and current oscillation. In many case it is not necessary to modify the default setting. Please make progressive change around default setting, since excessive setting will influence V/f control performance.

d1-18	Voltage setting on V/f separated pattern	Range: 0~5	Factory default: 0
-------	--	------------	--------------------

This parameter takes effect when d1-00 is set to 7 or 8.

0: d1-19 digital setting

Under V/f separated pattern 1, drive output voltage is completely determined by d1-19. 100% corresponds to motor rated voltage.

Under V/f separated pattern 2, output voltage = voltage calculated according to linear V/f curve x 2 x d1-19.

1: Set by AI1

2: Set by AI2

3: Set by EAI

Under V/f separated pattern 1, drive output voltage is completely determined by the selected analog. The biggest setting is the motor rated voltage.

Under V/f separated pattern 2, output voltage = voltage calculated according to linear V/f curve x the proportion determined by the analog input. The maximum set value can be 200%.

4: Process PID output

Outputs voltage on the basis of process PID.

Under V/f separated pattern 1, output voltage is determined by the output of process PID.

Under V/f separated pattern 2, the output of process PID is a proportional value whose maximum set value could be 200%. Then this proportional value is multiplied by the voltage calculated according to linear V/f curve to obtain drive output voltage. Refer to parameter group F0 for information of process PID.

5: AI1 + process PID output

Under V/f separated pattern 1, drive output voltage is determined by "AI1 + process PID output". The maximum set value of AI1 is motor rated voltage.

Under V/f separated pattern 2, "AI1 + process PID" output is a proportional value whose maximum set value corresponds to 200%. This proportional value is multiplied by the voltage calculated according to linear V/f to obtain drive output voltage.

d1-19	Digital set voltage on V/f separated pattern	Range: 0.0%~100.0%	Factory default: 0.0%
-------	--	--------------------	-----------------------

When 0 is selected at d1-18, the output voltage will be determined by d1-19.

d1-20	Voltage variation time on V/f separated pattern	Range: 0.00s~600.00s	Factory default: 0.01s
-------	---	----------------------	------------------------

Sets the output voltage change rate under V/f separation pattern. This parameter value is the time rising from 0V to motor rated voltage or dropping from rated voltage to 0V.

Group d2 Vector Control Parameters of Motor 1

Set control parameters in Group d2 when motor 1 is selected as current load motor on which sensor-less vector control is performed.

d2-00	Reserved	Reserved	Reserved
d2-01	ASR high-speed proportional gain Kp1	Range: 0.0~20.0	Factory default: 2.0
d2-02	ASR high-speed integration time Ti1	Range: 0.000s~8.000s	Factory default: 0.200
d2-03	ASR low-speed proportional gain Kp2	Range: 0.0~20.0	Factory default: 2.0
d2-04	ASR low-speed integration time Ti2	Range: 0.000s~8.000s	Factory default: 0.200
d2-05	ASR switching frequency 1	Range: 0.00Hz~d2-06	Factory default: 5.00Hz
d2-06	ASR switching frequency 2	Range: d2-05~upper limiting frequency	Factory default: 10.00Hz

Under sensor-less vector control (SVC), motor speed is kept at set value by automatic speed regulator (ASR). ASR parameters should be set in d2-01~d2-06.

The proportional gain Kp and integration time Ti of ASR can be set through d2-01~d2-04 so as to change the speed response characteristic under SVC. Increment of proportional gain Kp can bring in fast response of the system. However, bigger Kp value will bring about larger system oscillation.

Reduction of integration time Ti can also quicken response time, but small Ti value will result in big system overshooting and may easily bring about oscillation. Principle for adjustment of

proportional gain K_p and integration time T_i : proportional gain K_p is usually adjusted prior, maximizing K_p at the premise of ensuring the system is subject to no oscillation, and then adjust integration time T_i to provide the system with both instant response characteristic and less overshooting.

d2-01~d2-02 are the proportional gain and integration time of the drive at high speed. d2-03~d2-04 are the proportional gain and integration time of the drive at low speed. Distinction between high speed and low speed is determined by d2-05~d2-06. The diagram is as shown in Fig. 6-46.

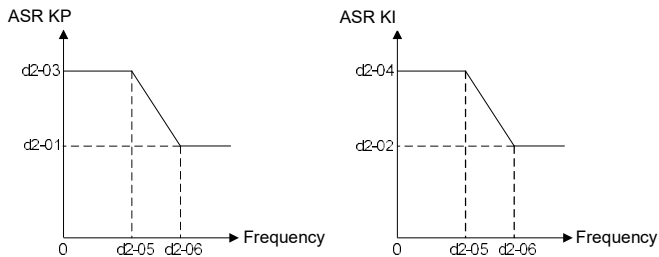

Fig. 6-46

ASR parameters are normally adjusted in the following order: select appropriate switching frequency. Adjust proportional gain d2 -01 and integration time d2-02 at high speed, ensuring the system has no oscillation and meets the requirements of dynamic response characteristics. Adjust proportional gain d2-03 and integration time d2-04 at low speed, ensuring there is no oscillation at low speed and requirements of dynamic response characteristics are met.

ATTENTION:

Inappropriate parameters of K_p , T_i may bring about overcurrent or overvoltage faults. Usually, fine adjustment should be performed close to factory default parameter.

d2-07	ASR input filtering time	Range: 0.0ms~500.0ms	Factory default: 5.0ms
-------	--------------------------	----------------------	---------------------------

Sets the input filtering time of ASR. No need to modify its default setting if there is no special requirement.

d2-08	ASR output filtering time	Range: 0.0ms~500.0ms	Factory default: 0.3ms
-------	---------------------------	----------------------	---------------------------

Sets the output filtering time of ASR. No need to modify its default setting if there is no special requirement.

d2-09	ACR proportion coefficient Kp	Range: 0.000~4.000	Factory default: 1.000
d2-10	ACR integration coefficient Ki	Range: 0.000~4.000	Factory default: 1.000

These two parameters determine the characteristics of automatic current regulator (ACR) under SVC pattern. Increment of proportion coefficient and/or integration coefficient can shorten torque response time. Reduction of proportion coefficient an/or integration coefficient can increase the stability of the system. Inappropriate setting may bring about system oscillation. Factory default is not needed to be changed in most cases.

d2-11	Pre-excitation time	Range: 0.000s~5.000s	Factory default: 0.200s
-------	---------------------	----------------------	----------------------------

Applies to asynchronous motor. To attain quick start, it is necessary to perform pre-excitation before the running of motor, and the pre-excitation time is set by this parameter. Properly establish stable flux prior and then ramp up quickly. The set value of 0.000s means "no pre-excitation" and ramp up at the moment of the receipt of run command. Pre-excitation time is not included in Accel/Decel time. Factory default is suggested to maintain in most cases.

d2-12	Driven torque restriction source	Range: 0~5	Factory default: 0
-------	-------------------------------------	------------	--------------------

Under the pattern of SVC speed control, and when the motor is driving an electric-driven load, it usually needs to restrict the output torque of the motor. This parameter sets the torque restriction source.

0: d2-14 digital setting

Restrict output torque through digital set parameter d2-14. 100% corresponds to motor rated torque.

1: AI1

2: AI2

3: EAI (on IO option board)

Limit the torque through analog input. The limited range is "0~200%r x rated torque".

4: X6/DI pulse input

Restrict the torque through X6/DI pulse input. The limited range is "0~200%r x rated torque".

5: Communication

A superior device sets the restricted value of the output torque through standard RS485 communication interface at the drive. Refer to parameter Group H0 and appendix for details of communication.

d2-13	Braking torque restriction source	Range: 0~5	Factory default: 0
-------	--------------------------------------	------------	--------------------

Under the pattern of SVC speed control, and when the motor is driving a power generating load,

it needs to restrict the output brake torque of the motor. This parameter sets the torque restriction source.

0: d2-15 digital setting

Restrict output brake torque through digital set parameter d2-15. 100% corresponds to rated torque of the motor.

1: AI1

2: AI2

3: EAI (on IO option board)

Limit the torque through analog input. The limited range is "0~200%r x rated torque".

4: X6/DI pulse input

Restrict the torque through X6/DI pulse input. The limited range is "0~200%r x rated torque".

5: Communication

A superior device sets the restricted value of the output torque through standard RS485 communication interface at the drive. Refer to parameter Group H0 and appendix for details of communication.

d2-14	Digital setting of driven torque	Range: 0.0%~200.0%	Factory default: 180.0%
-------	----------------------------------	--------------------	----------------------------

When 0 is selected for d2-12, this parameter value limits the maximum output driven torque. 100% corresponds to rated torque of the motor.

d2-15	Digital setting of brake torque	Range: 0.0%~200.0%	Factory default: 180.0%
-------	---------------------------------	--------------------	----------------------------

When d2-13 is set to 0, this parameter value limits the maximum output brake torque. 100% corresponds to rated torque of the motor.

d2-16	Torque limit coefficient in flux weakening	Range: 0.0%~100.0%	Factory default: 50.0%
-------	--	--------------------	---------------------------

Under the pattern of SVC speed control, and when the drive is running at frequency higher than rated frequency (flux weakening zone), appropriate torque limit coefficient can effectively improve the performance of output torque and Accel/Decel characteristics.

d2-17	Driven slip compensation gain	Range: 10.0%~300.0%	Factory default: 100.0%
-------	-------------------------------	---------------------	----------------------------

Under SVC pattern, adjustment of this parameter value can improve the speed accuracy when driving electric-driven load. If the load is becoming heavier and the motor speed is relatively lower, set a bigger value, while the motor speed is relatively higher, set a smaller value.

d2-18	Brake slip compensation gain	Range: 10.0%~300.0%	Factory default: 100.0%
-------	------------------------------	---------------------	----------------------------

Under SVC pattern, adjustment of this parameter value can improve the speed accuracy when driving power generating load. If the load is becoming heavier and the motor speed is relatively higher, set a bigger value, while the motor speed is relatively lower, set a smaller value.

Group d3 Parameters of Motor 2

When motor 2 is selected as current loaded motor, set motor parameters in Group d3. The specification of parameters of motor 2 in Group d3 is exactly the same with that of parameters of motor 1 in Group d0.

d3-00	Type of motor 2	Range: 0~2	Factory default: 0
d3-01	Power rating of motor 2	Range: 0.4kW~6553.5kW	Factory default: model dependent
d3-02	Rated voltage of motor 2	Range: 0V~480V	Factory default: 380V
d3-03	Rated current of motor 2	Range: 0.0A~6553.5A	Factory default: model dependent
d3-04	Rated frequency of motor 2	Range: 0.00Hz~upper limit frequency	Factory default: 50.00Hz
d3-05	Pole number of motor 2	Range: 1~80	Factory default: 4
d3-06	Rated speed of motor 2	Range: 0~65535 r/min	Factory default: model dependent
d3-07	Stator resistance R1 of asyn. motor 2	Range: 0.001Ω~65.535Ω	Factory default: model dependent
d3-08	Leakage inductance L1 of asyn. motor 2	Range: 0.1mH~6553.5mH	Factory default: model dependent
d3-09	Rotor resistance R2 of asyn. motor 2	Range: 0.001Ω~65.535Ω	Factory default: model dependent
d3-10	Mutual inductance L2 of asyn. motor 2	Range: 0.1mH~6553.5mH	Factory default: model dependent
d3-11	No-load current of asyn. motor 2	Range: 0.0A~6553.5A	Factory default: model dependent
d3-12	Flux weakening coeff 1 of asyn. motor 2	Range: 0.0000~1.0000	Factory default: model dependent
d3-13	Flux weakening coeff 2 of asyn. motor 2	Range: 0.0000~1.0000	Factory default: model dependent
d3-14	Flux weakening coeff 3 of asyn. motor 2	Range: 0.0000~1.0000	Factory default: model dependent
d3-15	Stator resistance of syn. motor 2	Range: 0.001Ω~65.535Ω	Factory default: 0.500Ω

d3-16	D-axis inductance of syn. motor 2	Range: 0.01mH~655.35mH	Factory default: 9.00mH
d3-17	Q-axis inductance of syn. motor 2	Range: 0.01mH~655.35mH	Factory default: 9.00mH
d3-18	Back EMF voltage of syn. motor 2	Range: 0.0~1000.0V	Factory default: 380.0V
d3-19	Autotuning current of syn. motor 2	Range: 0.0%~100.0%, 100% is motor rated current	Factory default: 35.0%
d3-22	Autotuning of motor 2	Range: 0~5	Factory default: 0
d3-23	Overload protection mode of motor 2	Range: 0~2	Factory default: 1
d3-24	Overload protection detection time of motor 2	Range: 0.1min~15.0min	Factory default: 5.0min
d3-25	Input channel of motor 2 temperature transducer signal	Range: 0~2	Factory default: 0
d3-26	Thermal protection threshold of motor 2 temperature transducer	Range: 0.00V~10.00V	Factory default: 10.00V
d3-27	Single phase current overload point	Range: 0.0%~400.0%	Factory default: 150.0%
d3-28	Single phase current overload time	Range: 0.001~50.000s	Factory default: 1.000s

Group d4 V/f Control Parameters of Motor 2

Set control parameters in Group d4 when motor 2 is selected as current loaded motor on which V/f control is performed. The specification of V/f control parameters of motor 2 in Group d4 is exactly the same with that of V/f control parameters of motor 1 in Group d1.

d4-00	V/f curve setting	Range: 0~8	Factory default: 0
d4-01	V/f frequency value f3	Range: 0.00Hz~rated frequency of motor	Factory default: 50.00Hz
d4-02	V/f voltage value V3	Range: 0.0%~100.0%	Factory default: 100.0%
d4-03	V/f frequency value f2	Range: d4-05~d4-01	Factory default: 0.00Hz
d4-04	V/f voltage value V2	Range: 0.0%~100.0%	Factory default: 0.0%

d4-05	V/f frequency value f1	Range: d4-07~d4-03	Factory default: 0.00Hz
d4-06	V/f voltage value V1	Range: 0.0%~100.0%	Factory default: 0.0%
d4-07	V/f frequency value f0	Range: 0.00Hz~d4-05	Factory default: 0.00Hz
d4-08	V/f voltage value V0	Range: 0.0%~100.0%	Factory default: 0.0%
d4-09	Torque boost	Range: 0.0%~30.0%	Factory default: 0.0%
d4-10	Slip compensation gain	Range: 0.0%~300.0%	Factory default: 100.0%
d4-11	Drooping FREQ of droop control	Range: 0.00Hz~maximum frequency	Factory default: 0.00Hz
d4-12	Current limitation source	Range: 0~5	Factory default: 1
d4-13	Digital setting of current limit value	Range: 20.0%~200.0%	Factory default: 160.0%
d4-14	Flux weakening current limit coeff	Range: 0.001~1.000	Factory default: 0.500
d4-15	Energy saving percentage	Range: 0.0%~40.0%	Factory default: 0.0%
d4-16	V/f oscillation suppression gain 1	Range: 0~3000	Factory default: 38
d4-17	V/f oscillation suppression gain 2	Range: 0~3000	Factory default: 0
d4-18	Voltage setting on V/f separated pattern	Range: 0~5	Factory default: 0
d4-19	Digital set voltage on V/f separated pattern	Range: 0.0%~100.0%	Factory default: 0.0%
d4-20	Voltage variation time on V/f separated pattern	Range: 0.00s~600.00s	Factory default: 0.01s

Group d5 Vector Control Parameters of Motor 2

Set control parameters in Group d5 when motor 2 is selected as current load motor on which SVC is performed. The specification of SVC parameters of motor 2 in Group d5 is exactly the same with that of SVC parameters of motor 1 in Group d3.

d5-00	Reserved	Reserved	Reserved
d5-01	ASR high-speed proportional gain Kp1	Range: 0.0~20.0	Factory default: 2.0
d5-02	ASR high-speed integration time Ti1	Range: 0.000s~8.000s	Factory default: 0.200
d5-03	ASR low-speed proportional gain Kp2	Range: 0.0~20.0	Factory default: 2.0
d5-04	ASR low-speed integration time Ti2	Range: 0.000s~8.000s	Factory default: 0.20
d5-05	ASR switching frequency 1	Range: 0.00Hz~d5-06	Factory default: 5.00Hz
d5-06	ASR switching frequency 2	Range: d5-05~upper limit frequency	Factory default: 10.00Hz
d5-07	ASR input filtering time	Range: 0.0ms~500.0ms	Factory default: 5.0ms
d5-08	ASR output filtering time	Range: 0.0ms~500.0ms	Factory default: 0.3ms
d5-09	ACR proportion coefficient Kp	Range: 0.000~4.000	Factory default: 1.000
d5-10	ACR integration coefficient Ki	Range: 0.000~4.000	Factory default: 1.000
d5-11	Pre-excitation time	Range: 0.000s~5.000s	Factory default: 0.200s
d5-12	Driven torque restriction source	Range: 0~5	Factory default: 0
d5-13	Braking torque restriction source	Range: 0~5	Factory default: 0
d5-14	Digital setting of driven torque limit value	Range: 0.0%~200.0%	Factory default: 180.0%
d5-15	Digital setting of braking torque limit value	Range: 0.0%~200.0%	Factory default: 180.0%
d5-16	Flux weakening torque limit coeff	Range: 0.0%~100.0%	Factory default: 50.0%
d5-17	Driven slip compensation gain	Range: 10.0%~300.0%	Factory default: 100.0%
d5-18	Brake slip compensation gain	Range: 10.0%~300.0%	Factory default: 100.0%

Group E Enhanced Function and Protection Parameters

Group E0 Enhanced Function

E0-00	Switching FREQ	Range: 0.7~16.0kHz	Model dependent
-------	----------------	--------------------	-----------------

With lower switching frequency, output current of the drive produces higher harmonics, motor loss increases, and temperature and motor noise rise, but drive temperature, drive leakage current, and drive interference to external devices are lower or less.

with higher switching frequency, drive temperature will rise, drive leakage current is bigger, and drive interference to external devices is bigger. However, motor loss and noise will be lower, and motor temperature will drop.

The table below specifies the setting range and factory default of PWM switching frequency of the drives at different power ratings:

Table 6-16

Power rating of the drives	Setting Range	Factory Default
≤15kW	0.7k~16k	8k
18.5kW~45kW	0.7k~10k	4k
55kW~75kW	0.7k~8k	3k
≥90kW	0.7k~3k	2k

Tips for PWM switching frequency setting:

- 1) When the motor line is too long, reduce switching frequency.
- 2) When torque at low speed is unstable, reduce switching frequency.
- 3) If the drive produces severe interference to surrounding equipment, reduce switching frequency.
- 4) Leakage current of the drive is big, reduce switching frequency.
- 5) Drive temperature rise is relatively high, reduce switching frequency.
- 6) Motor temperature rise is relatively high, increase switching frequency.
- 7) Motor noise is relatively big, increase switching frequency.

E0-01	PWM optimization	Range: 0000~1121	Factory default: 0100
-------	------------------	------------------	--------------------------

◆ Ones place: switching FREQ relation with temperature

0: Self-adaption

1: No adaption

When self-adaption of PWM switching frequency is selected, the drive will automatically reduce switching frequency with the temperature rise, protecting itself against overheat. Set to 1 where PWM switching frequency change is not allowed.

◆ Tens place: PWM modulation mode

0: five-segment and seven-segment self-switchover

1: five-segment mode

2: seven-segment mode

This selection is valid only for V/f control. When five-segment mode is selected, the drive has low temperature rise but relatively higher output current harmonic. Under seven-segment mode, it has relatively higher temperature rise but lower output current harmonic. Under SVC pattern, PWM is seven-segment mode.

◆ Hundreds place: over-modulation adaption

0: Disabled

1: Enabled

At low grid voltage or long-term heavy-duty operation, over-modulation can improve the voltage utilization and enhance the maximum voltage output capacity of the drive. This parameter takes effect only for V/f control, while over-modulation is enabled all the time under SVC pattern.

◆ Thousands place: PWM switching FREQ relation with output frequency

0: Self-adaption

1: No adaption

When this bit is set to 0, the drive running at low speed automatically reduces its switching frequency, so as to improve the motor load carrying capacity at low speed. Please set this bit to 1 if PWM switching frequency change is not allowed.

E0-02	Action when run time attained	Range: 000~111	Factory default: 000
-------	-------------------------------	----------------	----------------------

◆ Ones place: action when consecutive run time attained

0: Run continued

When the drive consecutive run time attains the set value of E0-03, the drive will continue to run.

1: Stop and fault reported

When the drive consecutive run time attains the set value of E0-03, the drive will report fault code "to2" and coast to stop. Digital output terminal "consecutive run time attained" will output ON. When E0-03 is set to 0, this parameter value is enabled.

◆ Tens place: action when accumulative run time attained

0: Run continued

When the drive accumulative run time attains the set value of E0-04, the drive will continue to run.

1: Stop and fault reported

When the drive accumulative run time attains the set value of E0-04, the drive will report fault "to3" and coast to stop. Digital output terminal "accumulative run time attained" will output ON. When E0-04 is set to 0, this parameter value is enabled.

◆ Hundreds place: unit of running time:

0: Second

1: Hour

Sets the unit of E0-03 consecutive run time and E0-04 accumulative run time.

E0-03	Consecutive run time setting	Range: 0.0~6000.0s(h)	Factory default: 0.0 s(h)
-------	------------------------------	-----------------------	---------------------------

When consecutive run time attains this set value, the drive will perform the action set by ones place of E0-02. Time unit is set at hundreds place of E0-02. When this parameter value is set to 0, this function is enabled.

E0-04	Accumulative run time setting	Range: 0.0~6000.0s(h)	Factory default: 0.0 s(h)
-------	-------------------------------	-----------------------	---------------------------

When accumulative run time attains this set value, the drive will perform the action set by tens place of E0-02. Time unit is set at hundreds place of E0-02. When this parameter value is set to 0, this function is enabled.

E0-05	Mechanical brake control	Range: 0~1	Factory default: 0
-------	--------------------------	------------	--------------------

0: Disabled

1: Enabled

Process of mechanical brake control is as shown as Fig. 6-47 below:

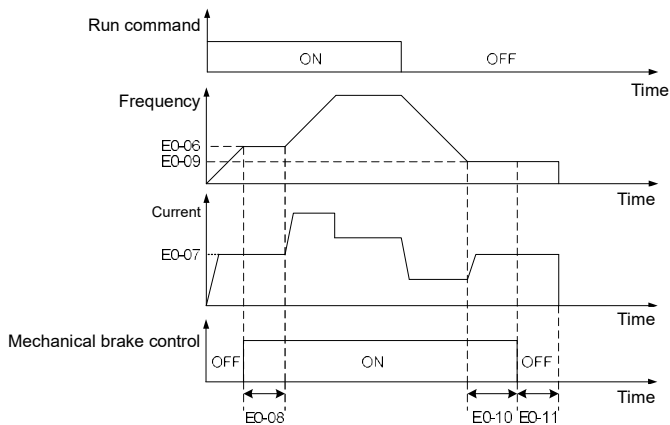

Fig. 6-47

- 1) Upon the receipt of run command, the drive will accelerate to the mechanical brake open frequency set by E0-06.
- 2) When frequency attains the value as set by E0-06, digital output terminal "mechanical brake control" outputs ON to control the mechanical brake open.

- 3) Perform constant-speed running at mechanical brake open frequency. During this period, the drive keeps the output current no higher than the current as set by E0-07.
- 4) When the run time at mechanical brake open frequency attains set value of E0-08, the drive will accelerate to set frequency.
- 5) Upon the receipt of stop command, the drive decelerate to mechanical brake close frequency set by E0-09 and maintains constant-speed run at this frequency.
- 6) When the run frequency attains the set value of E0-09, waiting a period of time set by E0-10, then digital output terminal "mechanical brake control" will output OFF signal to control mechanical brake close.
- 7) When the time of output OFF signal "mechanical brake control" attains the set value of E0-11, the drive will block the output and stop.

E0-06	Mechanical brake open frequency	Range: 0.00Hz~10.00Hz	Factory default: 2.50Hz
-------	---------------------------------	-----------------------	----------------------------

When frequency attains this value, digital output terminal "mechanical brake control" outputs ON signal to control the open of mechanical brake. This value can be set the same value as rated slip frequency of motor. Under V/f control, it could be set to a relatively large one.

E0-07	Mechanical brake open current	Range: 0.0%~200.0%	Factory default: 120.0%
-------	-------------------------------	--------------------	----------------------------

Current is limited to this value before the drive starts its acceleration from mechanical brake open frequency, i.e. before mechanical brake mechanism is opened.

E0-08	Accel delay time after brake open	Range: 0.0s~10.0s	Factory default: 1.0s
-------	-----------------------------------	-------------------	--------------------------

After digital output terminal "mechanical brake control" outputs ON signal, inverter will delay its Accel with this time. Accelerated running will be started after this set time is elapsed. Please set this parameter value in compliance with the time required for mechanism open of mechanical brake.

E0-09	Mechanical brake FREQ	Range: 0.00Hz~10.00Hz	Factory default: 2.00Hz
-------	-----------------------	-----------------------	----------------------------

Upon the receipt of stop command, the drive decelerates to mechanical brake close frequency set by E0-09 and maintains constant-speed running at this frequency, waiting for the output of mechanical brake control signal.

E0-10	Mechanical brake close waiting time	Range: 0.0s~10.0s	Factory default: 0.0s
-------	-------------------------------------	-------------------	--------------------------

When the run frequency attains mechanical brake close frequency, after this waiting time, digital output terminal "mechanical brake control" outputs OFF signal to control the mechanical brake close.

E0-11	Mechanical brake close holding time	Range: 0.0s~10.0s	Factory default: 1.0s
-------	-------------------------------------	-------------------	-----------------------

When the digital output terminal "mechanical brake control" outputs OFF signal, the frequency will be maintained the time set by E0-11 to ensure complete mechanism close. Then, the drive will block the output and stop.

Group E1 Protection Parameters

E1-00	Overvoltage stall	Range: 0~2	Factory default: 1
-------	-------------------	------------	--------------------

- 0: Invalid in all process
- 1: Valid in all process
- 2: Valid only for decelerating

When the motor is decelerating with a high-inertia load or short-term regenerative braking occurs during the run, the energy feedback to the drive may raise DC bus voltage, and thus resulting in overvoltage protection.

When this parameter value is set to 1, the drive will detect its bus voltage and compare with parameter set by E1-01. If the bus voltage exceeds value of E1-01, drive output frequency shall be adjusted instantaneously and the deceleration time shall be automatically prolonged, to maintain the stability of DC bus voltage. Set this parameter to 0 if frequency fluctuation or Decel time prolonging is not allowed.

E1-01	Overvoltage stall protection voltage	Range: 120%~150%	Factory default: 130%
-------	--------------------------------------	------------------	-----------------------

This value is a percentage compared to standard DC bus voltage.

E1-02	Undervoltage stall	Range: 0~1	Factory default: 0
-------	--------------------	------------	--------------------

- 0: Disabled
- 1: Enabled

Under momentary voltage drop or momentary power loss, the drive will accordingly drop output frequency, and compensate the voltage drop via the energy feedback from load, so as to maintain consecutive running, no trip. This function applies to fans and centrifugal pumps and such.

E1-03	Overload alarm	Range: 000~111	Factory default: 000
-------	----------------	----------------	----------------------

◆ Ones place: detection option

- 0: Always detect

Overload alarm works all the time during drive running.

1: Detect at constant speed only

Overload pre-alarm only works during constant-speed running of inverter.

◆ Tens place: compared with

0: motor rated current

Compared object is the rated current relative to motor, and display "oL2" when the alarm is given under this setting

1: drive rated current

Compared object is the rated current of drive, and display "oL1" when the alarm is given under this setting.

◆ Hundreds place: drive action

0: Alarm but run continued

When drive output current exceeds the level set by E1-04 and the lasting time attains parameter value of E1-05, the drive will alarm but continue its running.

1: Alarm and coast to stop

When drive output current exceeds the level set by E1-04 and the lasting time attains parameter value of E1-05, the drive will display overload fault and coast to stop.

E1-04	Overload alarm threshold	Range: 20.0%~200.0%	Factory default: 130.0%
-------	--------------------------	---------------------	----------------------------

When tens place of E1-03 is set to 0, this parameter value is a percentage compared to rated current of motor. When tens place of E1-03 is set to 1, this parameter value is a percentage compared to rated current of drive.

E1-05	Overload alarm activation time	Range: 0.1s~60.0s	Factory default: 5.0s
-------	--------------------------------	-------------------	--------------------------

Sets the lasting time that overload alarm is activated when output current of drive is bigger than the threshold set by E1-04.

E1-06	Protection action 1	Range: 0000~1111	Factory default: 0000
E1-07	Protection action 2	Range: 0000~3111	Factory default: 3001

These two parameters set the protection action of the drive in the following abnormal status.

Specification of E1-06:

◆ Ones place: reserved

◆ Tens place: temperature measurement circuit fault (OH3)

0: Coast to stop

1: Alarm but run continued

◆ Hundreds place: abnormal EEPROM (EPr)

0: Coast to stop

1: Alarm but run continued

◆ Thousands place: abnormal terminal communication (TrC)

0: Coast to stop

1: Alarm but run continued

Specification of E1- 07:

◆ Ones place: abnormal power supply when running (SUE)

0: Coast to stop

1: Alarm but run continued

◆ Tens place: current detection circuit failed (CtC)

0: Coast to stop

1: Alarm but run continued

◆ Hundreds place: abnormal contactor (CCL)

0: Coast to stop

1: Alarm but run continued

◆ Thousands place: input supply fault /output phase loss (ISF, oPL)

0: Protection for neither input supply fault nor output phase loss

1: No protection for input supply fault, protection enabled for output phase loss

2: Protection enabled for input supply fault, no protection for output phase loss

3: Protection enabled both for input supply fault and output phase loss

 **ATTENTION:**

Please set "protection action" with caution since inappropriate setting may extend the fault.

E1-08	Fault memory after power loss	Range: 0~1	Factory default: 0
-------	-------------------------------	------------	--------------------

Determine whether or not the previous fault code is to be memorized and displayed upon the power up of the drive after power loss.

0: Not memorized after power loss

1: Memorized after power loss

 **ATTENTION:**

Undervoltage fault "LoU" is not memorized after power loss.

E1-09	Fault auto-reset times	Range: 0~20	Factory default: 0
E1-10	Auto-reset interval	Range: 2.0s~20.0s	Factory default: 2.0s

When a fault occurs during the running, the drive will run at 0Hz with the time set by E1-10, and then the fault will be reset and the drive continues to run. Times of automatic reset is set by E1-09. Automatic reset is prohibited and fault protection shall be executed immediately when E1-09 is set to 0.

 **ATTENTION:**

1) Automatic fault reset is not performed at the following types of faults:

- Module protection "FAL"
- Parameter identification failed "tUN"
- Current detection abnormal "CtC"
- Ground short circuit protection at output side "GdP"
- Option board 1 connection abnormal "EC1"
- Converter module overload protection "oL3"
- Drive line connection abnormal "dLC"
- Analog terminal functional mutex (TEr)
- External equipment error "PEr"
- Consecutive run time attained "to2"
- Accumulative run time attained fault "to3"
- Power supply abnormal during running "SUE"
- Parameter copy fault "CPy"
- Software version compatibility failure "SFt"
- CPU interference fault "CPU"
- Reference protection "oCr"
- 5V power supply out-of-limit "SP1"
- Undervoltage protection "LoU"
- PID feedback loss "PlO"

2) Please use automatic fault reset function with caution, or fault will be extended.

E1-11	Relay action on drive fault	Range: 000~111	Factory default: 010
-------	-----------------------------	----------------	-------------------------

◆ Ones place: when undervoltage fault occurs

0: No action

1: Action enabled

Set whether or not fault relay acts when undervoltage occurs.

◆ Tens place: when fault locked

0: No action

1: Action enabled

Set whether or not the relay acts when the fault locked at latest power loss after power up.

◆ Hundred's place: at interval of auto- reset

0: No action

1: Action enabled

Set whether or not the relay acts when fault occurs in automatic reset status.

E1-12	Cooling fan control	Range: 0~1	Factory default: 0
-------	---------------------	------------	--------------------

0: Auto run

The fans run all the time during the running. Determine if the fans continue to run or stop

according to module temperature after stop.

1: Always run after power up

The fans run all the time after applying power to the drive.

E1-13	Drive overheat alarm threshold	Range: 0.0°C~100.0°C	Factory default: 80.0°C
-------	--------------------------------	----------------------	-------------------------

This parameter sets the threshold of drive overheat alarm.

Group F Application

Group F0 Process PID

The purpose of process PID control is to make feedback value consistent with the set value. PID control diagram is shown as Fig. 6-48.

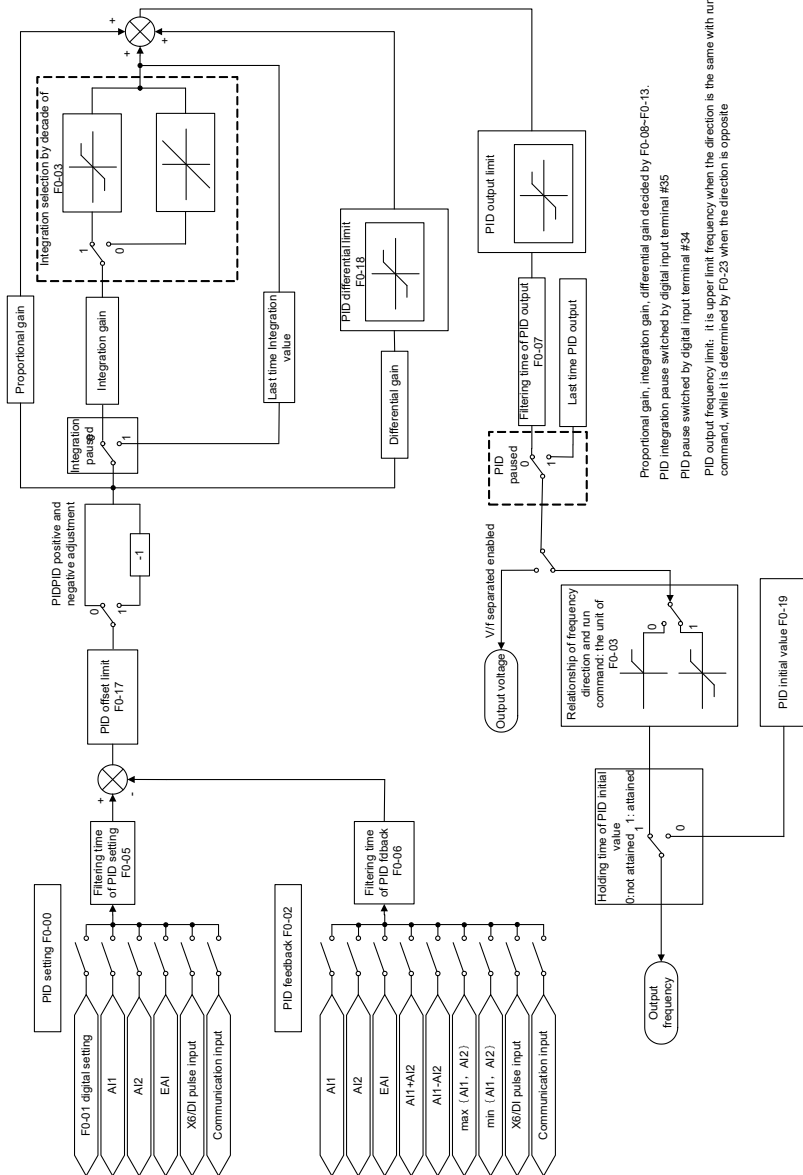

Proportional gain, integration gain, differential gain decided by F0-06-F0-13.
 PID integration pause switched by digital input terminal #35
 PID pause switched by digital input terminal #34
 PID output frequency limit: it is upper limit frequency when the direction is the same with run command, while it is determined by F0-23 when the direction is opposite

Fig. 6-48

F0-00	PID setting	Range: 0~5	Factory default: 0
-------	-------------	------------	--------------------

Select the setting source of PID control.

0: F0-01 digital setting

1:AI1

2:AI2

3: EAI (on IO option board)

4: X6/DI pulse input

5: Communication input

F0-01	PID digital setting	Range: 0.0%~100.0%	Factory default: 50.0%
-------	---------------------	--------------------	------------------------

When F0-00 is set to 0, this parameter value is taken as the set value of PID.

F0-02	PID feedback	Range: 0~8	Factory default: 0
-------	--------------	------------	--------------------

Select the feedback source of PID control.

0:AI1

1:AI2

2: EAI (on IO option board)

3:AI1+AI2

4:AI1-AI2

5:max {AI1, AI2}

6:min {AI1, AI2}

7: X6/DI pulse input

8: Communication input

F0-03	PID adjustment	Range: 00~11	Factory default: 11
-------	----------------	--------------	---------------------

◆ Ones place: output frequency

0: Must be the same direction as the set run direction

When PID frequency output direction is opposite to the rotary set direction, PID output is 0.

1: Opposite direction allowed

PID frequency output direction can be opposite to the rotary set direction, and PID output performs normally.

◆ Tens place: integration selection

0: Integral continued when frequency attains upper/lower frequency

Under PID control, when output frequency attains upper/lower limit of frequency or parameter value of F0-23 (maximum frequency if it is opposite to the rotary set direction), PID integral continues. This mode requires longer time of quitting saturation.

1: Integral stopped when frequency attains upper/lower limit

Under PID control, when output frequency attains upper/lower limit of frequency or parameter value of F0-23 (maximum frequency if it is opposite to the rotary set direction), PID integral will cease. This mode can quit integral saturation status rapidly.

F0-04	PID positive and negative adjustment	Range: 0~1	Factory default: 0
-------	--------------------------------------	------------	--------------------

0: Positive adjustment

1: Negative adjustment

This parameter can be used with digital input terminal "PID adjustment direction" to select positive or negative adjustment of PID.

Table 6-17

F0-04	PID adjustment direction terminal	Adjustment
0	OFF	Positive
0	ON	Negative
1	OFF	Negative
1	ON	Positive

Positive adjustment: when feedback signal is smaller than PID setting, output frequency of the drive will rise to reach PID balance.

when feedback signal is bigger than PID setting, output frequency of the drive will drop to reach PID balance.

Negative adjustment: when feedback signal is smaller than PID setting, output frequency of the drive will drop to reach PID balance.

when feedback signal is bigger than PID setting, output frequency of the drive will rise to reach PID balance.

F0-05	Filtering time of PID setting	Range: 0.00s~60.00s	Factory default: 0.00s
F0-06	Filtering time of PID feedback	Range: 0.00s~60.00s	Factory default: 0.00s
F0-07	Filtering time of PID output	Range: 0.00s~60.00s	Factory default: 0.00s

Set the filtering time of PID setting, feedback and output.

F0-08	Proportional gain Kp1	Range: 0.0~200.0	Factory default: 50.0
F0-09	Integration time Ti1	Range: 0.000s~50.000s	Factory default: 0.500s
F0-10	Derivative time Td1	Range: 0.000s~50.000s	Factory default: 0.000s

Process PID is provided with two groups of proportion, integral and differential parameters set by F0-14. F0-08~F0-10 are the first group of parameters.

Proportional gain Kp: dynamic response of the system can be quickened by increasing proportional gain Kp. However, excessive Kp value would bring about system oscillation. Only proportional gain control cannot eliminate steady state error.

Integration time: dynamic response of the system can be quickened by reducing integration time Ti. However, excessively small Ti value would result in serious system overshooting and may easily bring about oscillation. Integral control can be used to eliminate steady state error but is unable to control sharp changes.

Differential time Td: it can predict the change trend of offset and thus can rapidly respond to the change, improving dynamic performance. However, this is vulnerable to interference. Please use differential control with caution.

F0-11	Proportional gain Kp2	Range: 0.0~200.0	Factory default: 50.0
F0-12	Integration time Ti2	Range: 0.000s~50.000s	Factory default: 0.500s
F0-13	Derivative time Td2	Range: 0.000s~50.000s	Factory default: 0.000s

Process PID is provided with two groups of proportion, integral and differential parameters set by F0-14. F0-11~ F0-13 are the second group of parameters.

F0-14	PID parameter switch	Range: 0~2	Factory default: 0
-------	----------------------	------------	--------------------

Process PID is provided with two groups of proportional, integral and differential parameters, which is set by this parameter.

0: No switch, determined by parameters Kp1, Ti1 and Td1

Always determined by Kp1, Ti1 and Td1 set at F0-08~F0-10.

1: Auto switched on the basis of input offset

When the offset between setting and feedback is less than the set value of F0-15, PID adjustment is determined by Kp1, Ti1 and Td1. When the offset between setting and feedback is bigger than the set value of F0-15, PID adjustment is determined by Kp2, Ti2 and Td2 set at F0-11~F0-13.

2: Switched by terminal

When digital input terminal "PID parameters switch" is OFF, it is determined by Kp1, Ti1 and Td1. When "PID parameters switch" is ON, it is determined by Kp2, Ti2 and Td2

F0-15	Input offset under PID auto switch	Range: 0.0%~100.0%	Factory default: 20.0%
-------	---------------------------------------	--------------------	---------------------------

When F0-14 is set to 1, this parameter sets the switching point of the two groups of PID parameters. When the offset between setting and feedback is less than this set value, it is

determined by Kp1, Ti1 and Td1. When the offset between setting and feedback is bigger than this set value, it is determined by Kp2, Ti2 and Td2.

F0-16	Sampling period T	Range: 0.001s~50.000s	Factory default: 0.002s
-------	-------------------	-----------------------	----------------------------

Sampling period aims at feedback. PID controller performs the sampling and compute once in each sampling period. The longer the sampling period T is, the slower the response time will be.

F0-17	PID offset limit	Range: 0.0%~100.0%	Factory default: 0.0%
-------	------------------	--------------------	--------------------------

If the offset between PID feedback and setting is more than this set value, PID regulator will implement regulation. If the offset between PID feedback and setting is less than this set value, PID will stop the regulation and the PID controller output will be kept unchanged. This function can improve the stability of PID performance.

F0-18	PID derivative limit	Range: 0.0%~100.0%	Factory default: 0.5%
-------	----------------------	--------------------	--------------------------

Sets differential output limit of PID control.

F0-19	PID initial value	Range: 0.0%~100.0%	Factory default: 0.0%
F0-20	PID initial value holding time	Range: 0.0s~3600.0s	Factory default: 0.0s

PID does not make adjustment when the drive starts its running, but outputs the value set by F0-19 and maintains the holding time set by F0-20, then starts PID adjustment. When F0-20 is set to 0, PID initial value is disabled. This function makes PID adjustment get into stable status fast.

F0-21	PID feedback loss detection value	Range: 0.0%~100.0%	Factory default: 0.0%
F0-22	PID feedback loss detection time	Range: 0.0s~30.0s	Factory default: 1.0s

When offset between feedback and setting of PID is bigger than set value of F0-21 and the lasting time attains the set time of F0-22, the drive reports fault "Plo". If F0-22 is set to 0, feedback loss detection is disabled.

F0-23	Cutoff FREQ when opposite to rotary set direction	Range: 0.00Hz~maximum frequency	Factory default: 50.00Hz
-------	---	---------------------------------	-----------------------------

When rotary set direction is forward, while PID output is reverse, the maximum reverse

frequency will be determined by F0-23. When rotary set direction is reverse, while PID output is forward, the maximum forward frequency will be determined by F0-23.

F0-24	PID computation option	Range: 0~1	Factory default: 0
-------	------------------------	------------	--------------------

- 0: No computation in stop status
- 1: Computation continued in stop status

Group F1 Multi-step Frequency

F1-00	FREQ set source of multi-step 0	Range: 0~8	Factory default: 0
-------	---------------------------------	------------	--------------------

- 0: Digital setting F1-02
- 1: Digital setting b0-02 + control panel \wedge/\vee adjustment
- 2: Digital setting b0-02 + terminal UP/DOWN adjustment
- 3:AI1
- 4:AI2
- 5: EAI (on IO option board)
- 6: X6/DI pulse input
- 7: Process PID output
- 8: Communication input

At most 16-step of frequency can be set through the combination of "multi-step frequency terminals 1~4" of digital input. Multi-step frequency 2~15 are only digital setting while a number of setting sources can be selected for multi-step frequency 0~1. Parameter value of F1-00 determines command source of step 0.

F1-01	FREQ set source of multi-step 1	Range: 0~8	Factory default: 0
-------	---------------------------------	------------	--------------------

- 0: Digital setting F1-03
- 1: Digital setting b0-04 + control panel \wedge/\vee adjustment
- 2: Digital setting b0-04 + terminal UP/DOWN adjustment
- 3:AI1
- 4:AI2
- 5: EAI (on IO option)
- 6: X6/DI pulse input
- 7: Process PID output
- 8: Communication input

At most 16-step of frequency can be set through the combination of "multi-step frequency terminals 1~4" of digital input. Multi-step frequency 2~15 are only digital setting while a number of setting sources can be selected for multi-step frequency 0~1. Parameter value of F1-01 determines command source of step 1.

F1-02	Multi-step frequency 0	Range: -100.0%~100.0%	Factory default: 0.0%
F1-03	Multi-step frequency 1	Range: -100.0%~100.0%	Factory default: 0.0%
F1-04	Multi-step frequency 2	Range: -100.0%~100.0%	Factory default: 0.0%
F1-05	Multi-step frequency 3	Range: -100.0%~100.0%	Factory default: 0.0%
F1-06	Multi-step frequency 4	Range: -100.0%~100.0%	Factory default: 0.0%
F1-07	Multi-step frequency 5	Range: -100.0%~100.0%	Factory default: 0.0%
F1-08	Multi-step frequency 6	Range: -100.0%~100.0%	Factory default: 0.0%
F1-09	Multi-step frequency 7	Range: -100.0%~100.0%	Factory default: 0.0%
F1-10	Multi-step frequency 8	Range: -100.0%~100.0%	Factory default: 0.0%
F1-11	Multi-step frequency 9	Range: -100.0%~100.0%	Factory default: 0.0%
F1-12	Multi-step frequency 10	Range: -100.0%~100.0%	Factory default: 0.0%
F1-13	Multi-step frequency 11	Range: -100.0%~100.0%	Factory default: 0.0%
F1-14	Multi-step frequency 12	Range: -100.0%~100.0%	Factory default: 0.0%
F1-15	Multi-step frequency 13	Range: -100.0%~100.0%	Factory default: 0.0%
F1-16	Multi-step frequency 14	Range: -100.0%~100.0%	Factory default: 0.0%
F1-17	Multi-step frequency 15	Range: -100.0%~100.0%	Factory default: 0.0%

 ATTENTION:

F1-02~F1-17 is relevant to upper limit b0-09

At most 16 steps of multi-step frequency can be set by different status combinations of "multi-step frequency terminals 1~4" of digital input, as shown in Table 6-18.

Table 6-18

Multi-step terminal 4	Multi-step terminal 3	Multi-step terminal 2	Multi-step terminal 1	Command frequency
OFF	OFF	OFF	OFF	Multi-step frequency 0(F1-00)
OFF	OFF	OFF	ON	Multi-step frequency 1(F1-01)
OFF	OFF	ON	OFF	Multi-step frequency 2(F1-04)
OFF	OFF	ON	ON	Multi-step frequency 3(F1-05)
OFF	ON	OFF	OFF	Multi-step frequency 4(F1-06)
OFF	ON	OFF	ON	Multi-step frequency 5(F1-07)
OFF	ON	ON	OFF	Multi-step frequency 6(F1-08)
OFF	ON	ON	ON	Multi-step frequency 7(F1-09)
ON	OFF	OFF	OFF	Multi-step frequency 8(F1-10)
ON	OFF	OFF	ON	Multi-step frequency 9(F1-11)
ON	OFF	ON	OFF	Multi-step frequency 10(F1-12)
ON	OFF	ON	ON	Multi-step frequency 11(F1-13)
ON	ON	OFF	OFF	Multi-step frequency 12(F1-14)
ON	ON	OFF	ON	Multi-step frequency 13(F1-15)
ON	ON	ON	OFF	Multi-step frequency 14(F1-16)
ON	ON	ON	ON	Multi-step frequency 15(F1-17)

Group F2 Simple PLC

Simple PLC is a multi-step frequency generator. The drive can automatically change run frequency and direction based on the run time so as to meet on-site technological requirements. Flow chart is shown as Fig. 6-49.

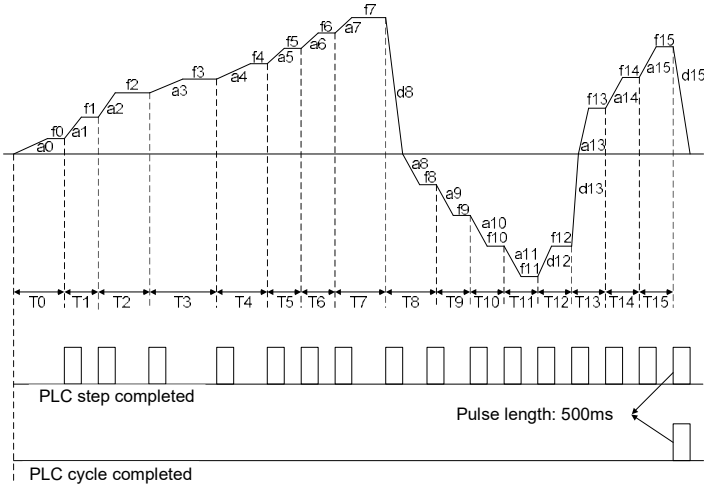

Fig. 6-49

a0~a15 are the Accel times of steps, while d0~d15 are the Decel times.
f0~f15 are the set frequencies of steps while T0~T15 are the run times.

Upon the completion of current step of simple PLC, digital output terminal "PLC step completed" outputs ON signal, 500ms. When simple PLC finishes a run cycle, digital output terminal "PLC cycle completed" outputs ON signal, 500ms.

F2-00	Simple PLC run mode	Range: 0000~1212	Factory default: 0000
-------	---------------------	------------------	--------------------------

◆ Ones place: PLC run mode

0: Stop after a single cycle

PLC stops upon the completion of one cycle and it won't be started unless another run command is given, shown as Fig. 6-50.

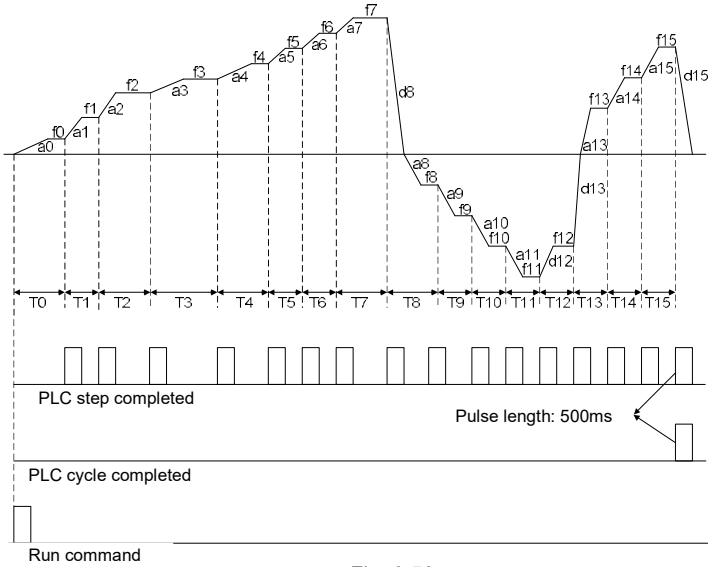

Fig. 6-50

1: Continue to run in the last FREQ after a single cycle

After the completion of one cycle, PLC maintains the run frequency and direction of the last step. See the figure below:

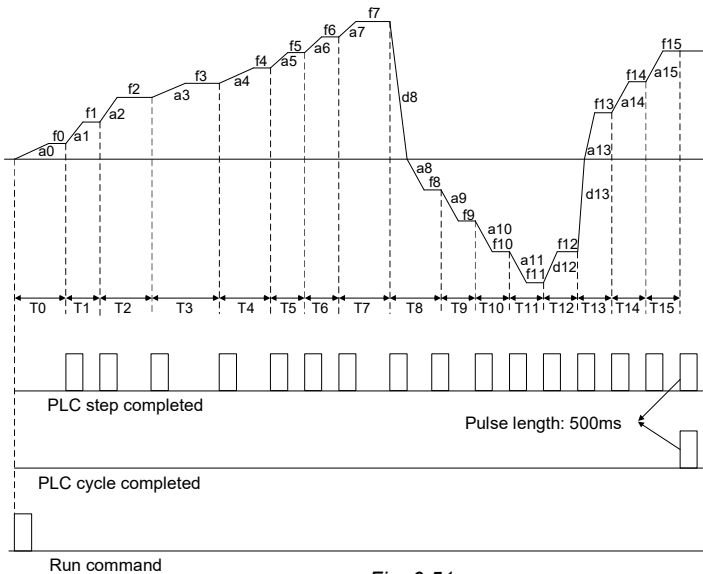

Fig. 6-51

2: Cycle repeated

PLC automatically starts another cycle after finishing one cycle until there is a stop command, shown as Fig. 6-52.

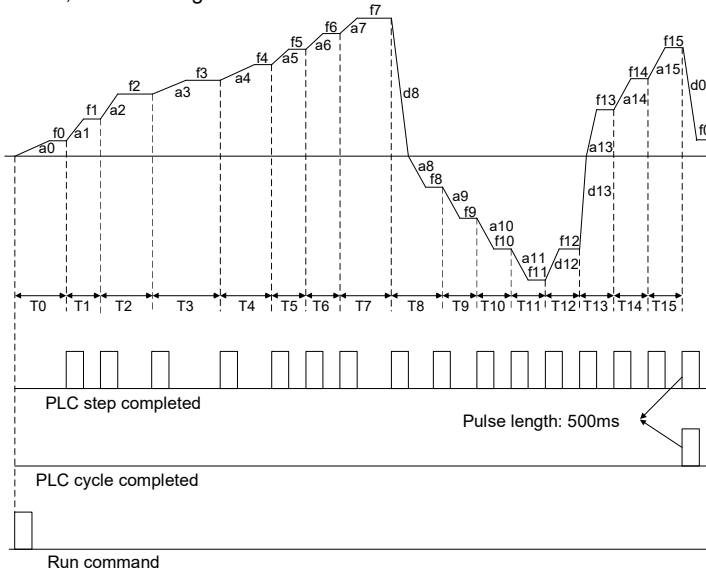

Fig. 6-52

◆ Tens place: power loss memory

0: No memory on power loss

The drive does not memorize PLC run status on power loss and starts the run from step 0 after power up again.

1: Memorized on power loss

The drive saves PLC run status on power loss, including the run step, run frequency and finished run time at the moment of power loss. After the next power up, the run will be continued in accordance with the memorized status.

◆ Hundreds place: starting mode

0: Run from the first step “multi-step frequency 0”

When restarted after stop, the drive will start to run from “step 0”.

1: Continue to run from the step of stop (or fault)

At the moment drive stop, the drive automatically records the run time of current step. When restarted, the drive will get into this step, continue to run the remanent time with the frequency of this step, shown as Fig. 6-53.

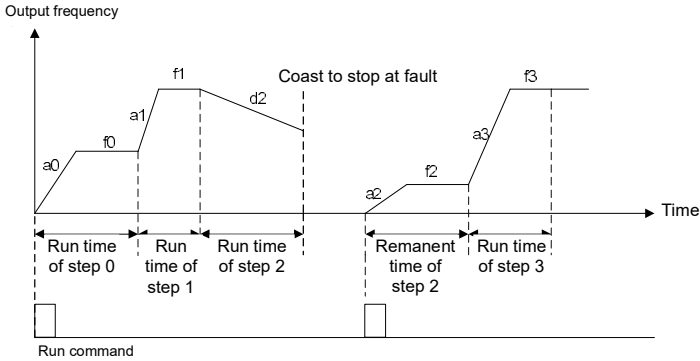

Fig. 6-53

2: Continue to run from the step and frequency at which the run stopped (or fault occurred)

At the moment of stop, the drive not only records the run time of current step, but also records the run frequency at the moment of stop. When restarted, it will restore the run frequency that was recorded at the moment of stop, and then continue to run the remanent step, as shown in Fig. 6-54:

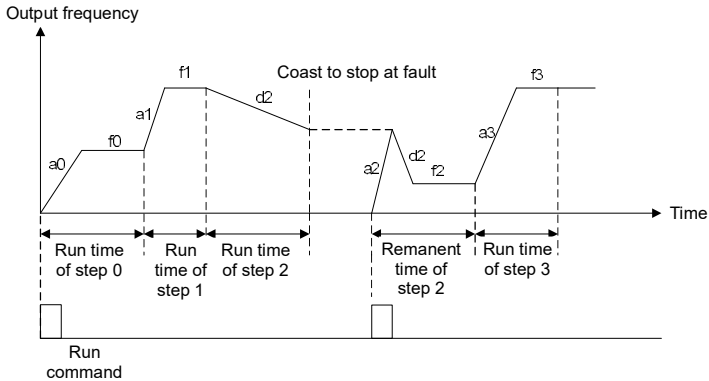

Fig. 6-54

◆ Thousands place: unit of simple PLC run time

0: Second

1: Minute

Sets the unit of running time and Accel/Decel time of simple PLC.

F2-01	Setting of multi-step 0	Range: 000~327	Factory default: 000
-------	-------------------------	----------------	-------------------------

◆ Ones place: frequency setting

Sets the frequency of step 0 of simple PLC.

0: Multi-step frequency 0 (F1-02)

1: AI1

2: AI2

3: EAI (on IO option board)

4: X6/DI pulse input

5: Process PID output

6: Multi-step frequency

7: Communication input

◆ Tens place: run direction

Sets the run direction for step 0 of simple PLC.

0: Forward

1: Reverse

2: Determined by run command

◆ Hundreds place: Accel/Decel time option

Sets the Accel/Decel time step 0.

0: Accel/Decel time 1

1: Accel/Decel time 2

2: Accel/Decel time 3

3: Accel/Decel time 4

The Accel/Decel time of simple PLC running is set here, not determined by digital input terminal "Accel/Decel time determinant 1~2". In addition, Accel/Decel time unit is set through thousands place of F2-00 and is independent of the setting of b2-00.

F2-02	Run time of step 0	Range: 0.0~6000.0s(min)	Factory default: 0.0s
-------	--------------------	-------------------------	--------------------------

Sets the run time for step 0 of simple PLC and the time unit is set by thousands place of F2-00.

F2-03	Setting of step 1	Range: 000~327	Factory default: 000
-------	-------------------	----------------	-------------------------

◆ Ones place: frequency setting

0: Multi-step frequency 1 (F1-03)

1~7: same as F2-01

◆ Tens place: run direction (same as F2-01)

◆ Hundreds place: Accel/Decel time option (same as F2-01)

F2-04	Run time of step 1	Range: 0.0~6000.0s(min)	Factory default: 0.0s
-------	--------------------	-------------------------	--------------------------

Sets the run time for step 1 of simple PLC and the time unit is set by thousands place of F2-00.

F2-05	Setting of step 2	Range: 000~327	Factory default: 000
-------	-------------------	----------------	-------------------------

◆ Ones place: frequency setting

0: Multi-step frequency 2 (F1-04)

1~7: same as F2-01

◆ Tens place: run direction (same as F2-01)

◆ Hundreds place: Accel/Decel time option (same as F2-01)

F2-06	Run time of step 2	Range: 0.0~6000.0s(min)	Factory default: 0.0s
-------	--------------------	-------------------------	--------------------------

Sets the run time of step 2. The time unit is set by thousands place of F2-00.

F2-07	Setting of step 3	Range: 000~327	Factory default: 000
-------	-------------------	----------------	-------------------------

◆ Ones place: frequency setting

0: Multi-step frequency 3 (F1-05)

1~7: same as F2-01

◆ Tens place: run direction (same as F2-01)

◆ Hundreds place: Accel/Decel time option (same as F2-01)

F2-08	Run time of step 3	Range: 0.0~6000.0s(min)	Factory default: 0.0s
-------	--------------------	-------------------------	--------------------------

Sets the run time of step 3 of simple PLC. The time unit is set by thousands place of F2-00.

F2-09	Setting of step 4	Range: 000~327	Factory default: 000
-------	-------------------	----------------	-------------------------

◆ Ones place: frequency setting

0: Multi-step frequency 4 (F1-06)

1~7: same as F2-01

◆ Tens place: run direction (same as F2-01)

◆ Hundreds place: Accel/Decel time option (same as F2-01)

F2-10	Run time of step 4	Range: 0.0~6000.0s(min)	Factory default: 0.0s
-------	--------------------	-------------------------	--------------------------

Sets the run time of step 4 of simple PLC. The time unit is set by thousands place of F2-00.

F2-11	Setting of step 5	Range: 000~327	Factory default: 000
-------	-------------------	----------------	-------------------------

◆ Ones place: frequency setting

0: Multi-step frequency 5 (F1-07)

1~7: same as F2-01

◆ Tens place: run direction (same as F2-01)

◆ Hundreds place: Accel/Decel time option (same as F2-01)

F2-12	Run time of step 5	Range: 0.0~6000.0s(min)	Factory default: 0.0s
-------	--------------------	-------------------------	--------------------------

Sets the run time of step 5 of simple PLC. The time unit is set by thousands place of F2-00.

F2-13	Setting of step 6	Range: 000~327	Factory default: 000
-------	-------------------	----------------	-------------------------

◆ Ones place: frequency setting

0: Multi-step frequency 6 (F1-08)

1~7: same as F2-01

◆ Tens place: run direction (same as F2-01)

◆ Hundreds place: Accel/Decel time option (same as F2-01)

F2-14	Run time of step 6	Range: 0.0~6000.0s(min)	Factory default: 0.0s
-------	--------------------	-------------------------	--------------------------

Sets the run time of step 6 of simple PLC. The time unit is set by thousands place of F2-00.

F2-15	Setting of step 7	Range: 000~327	Factory default: 000
-------	-------------------	----------------	-------------------------

◆ Ones place: frequency setting

0: Multi-step frequency 7 (F1-09)

1~7: same as F2-01

◆ Tens place: run direction (same as F2-01)

◆ Hundreds place: Accel/Decel time option (same as F2-01)

F2-16	Run time of step 7	Range: 0.0~6000.0s(min)	Factory default: 0.0s
-------	--------------------	-------------------------	--------------------------

Sets the run time of step 7 of simple PLC. The time unit is set by thousands place of F2-00.

F2-17	Setting of step 8	Range: 000~327	Factory default: 000
-------	-------------------	----------------	-------------------------

◆ Ones place: frequency setting

0: Multi-step frequency 8 (F1-10)

1~7: same as F2-01

◆ Tens place: run direction (same as F2-01)

◆ Hundreds place: Accel/Decel time option (same as F2-01)

F2-18	Run time of step 8	Range: 0.0~6000.0s(min)	Factory default: 0.0s
-------	--------------------	-------------------------	--------------------------

Sets the run time of step 8 of simple PLC. The time unit is set by thousands place of F2-00.

F2-19	Setting of step 9	Range: 000~327	Factory default: 000
-------	-------------------	----------------	-------------------------

◆ Ones place: frequency setting

0: Multi-step frequency 9 (F1-11)

1~7: same as F2-01

◆ Tens place: run direction (same as F2-01)

◆ Hundred's place: Accel/Decel time option (same as F2-01)

F2-20	Run time of step 9	Range: 0.0~6000.0s(min)	Factory default: 0.0s
-------	--------------------	-------------------------	--------------------------

Sets the run time for step 9 of simple PLC. The time unit is set by thousands place of F2-00.

F2-21	Setting of step 10	Range: 000~327	Factory default: 000
-------	--------------------	----------------	-------------------------

◆ Ones place: frequency setting

0: Multi-step frequency 10 (F1-12)

1~7: same as F2-01

◆ Tens place: run direction (same as F2-01)

◆ Hundreds place: Accel/Decel time option (same as F2-01)

F2-22	Run time of step 10	Range: 0.0~6000.0s(min)	Factory default: 0.0s
-------	---------------------	-------------------------	--------------------------

Sets the run time of step 10 of simple PLC. The time unit is set by thousands place of F2-00.

F2-23	Setting of step 11	Range: 000~327	Factory default: 000
-------	--------------------	----------------	-------------------------

◆ Ones place: frequency setting

0: Multi-step frequency 11 (F1-13)

1~7: same as F2-01

- ◆ Tens place: run direction (same as F2-01)
- ◆ Hundreds place: Accel/Decel time option (same as F2-01)

F2-24	Run time of step 11	Range: 0.0~6000.0s(min)	Factory default: 0.0s
-------	---------------------	-------------------------	--------------------------

Sets the run time of step 11 of simple PLC. The time unit is set by thousands place of F2-00.

F2-25	Setting of step 12	Range: 000~327	Factory default: 000
-------	--------------------	----------------	-------------------------

- ◆ Ones place: frequency setting
- 0: Multi-step frequency 12 (F1-14)
1~7: same as F2-01

- ◆ Tens place: run direction (same as F2-01)
- ◆ Hundreds place: Accel/Decel time option (same as F2-01)

F2-26	Running time of step 12	Range: 0.0~6000.0s(min)	Factory default: 0.0s
-------	-------------------------	-------------------------	--------------------------

Sets the run time of step 12 of simple PLC. The time unit is set by thousands place of F2-00.

F2-27	Setting of step 13	Range: 000~327	Factory default: 000
-------	--------------------	----------------	-------------------------

- ◆ Ones place: frequency setting
- 0: The time unit is set by thousands place of F2-00.
1~7: same as F2-01

- ◆ Tens place: run direction (same as F2-01)
- ◆ Hundreds place: Accel/Decel time option (same as F2-01)

F2-28	Run time of step 13	Range: 0.0~6000.0s(min)	Factory default: 0.0s
-------	---------------------	-------------------------	--------------------------

Sets the run time of step 13 of simple PLC. The time unit is set by thousands place of F2-00.

F2-29	Setting of step 14	Range: 000~327	Factory default: 000
-------	--------------------	----------------	-------------------------

- ◆ Ones place: frequency setting
- 0: Multi-step frequency 14 (F1-16)
1~7: same as F2-01

- ◆ Tens place: run direction (same as F2-01)
- ◆ Hundreds place: Accel/Decel time option (same as F2-01)

F2-30	Run time of step 14	Range: 0.0~6000.0s(min)	Factory default: 0.0s
-------	---------------------	-------------------------	--------------------------

Sets the run time of step 14 of simple PLC. The time unit is set by thousands place of F2-00.

F2-31	Setting of step 15	Range: 000~327	Factory default: 000
-------	--------------------	----------------	-------------------------

◆ Ones place: frequency setting

0: Multi-step frequency 15 (F1-17)

1~7: same as F2-01

◆ Tens place: run direction (same as F2-01)

◆ Hundreds place: Accel/Decel time option (same as F2-01)

F2-32	Run time of step 15	Range: 0.0~6000.0s(min)	Factory default: 0.0s
-------	---------------------	-------------------------	--------------------------

Sets the run time for step 15 of simple PLC. The time unit is set by thousand's place of F2-00.

 **ATTENTION:**

Digital input terminals "simple PLC paused", "simple PLC disabled" and "simple PLC stop memory clear" can be used during the running of simple PLC. See specification of digital input of Group C0 for details.

Group F3 Wobble Frequency and Fixed Length Count

Wobble frequency function is usually used in textile and chemical fiber industries where traverse motion is required. Wobble frequency control process is as follows: accelerate to the pre-frequency of wobble frequency function according to the current Accel time. Maintain this frequency for a period of time and run to center frequency of wobble frequency according to the current Accel/Decel time (i.e. the set frequency set by parameter group b0). Then run in a cyclic manner according to wobble frequency amplitude, hopping frequency, wobble frequency cycle time, and frequency ramp up time. When a stop command is given, the drive will ramp down to stop according to the set Decel time.

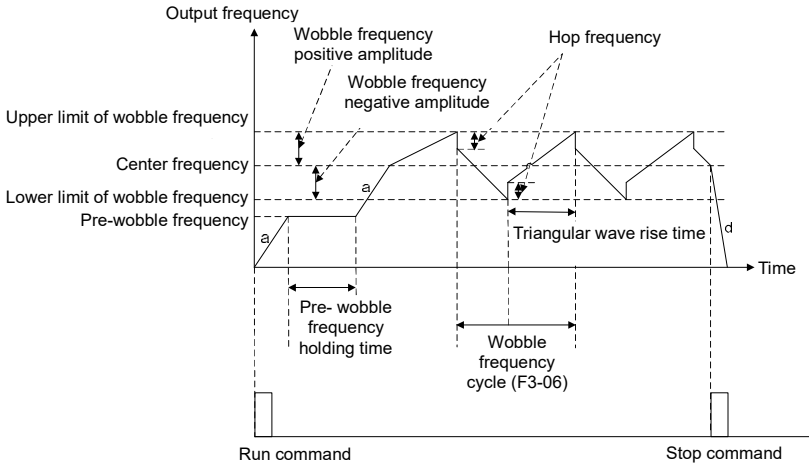

Fig. 6-55

a is the set Accel time (ramp up time), and d is the set Decel time (ramp down time).

F3-00	Wobble frequency function setting	Range: 0~1	Factory default: 0
-------	-----------------------------------	------------	--------------------

- 0: Wobble frequency function disabled
- 1: Wobble frequency function enabled

F3-01	Wobble frequency run setting	Range: 0000~1111	Factory default: 0000
-------	------------------------------	------------------	-----------------------

◆ Ones place: started method

0: Automatically

Run at pre-frequency of wobble frequency set by F3-02, maintain Pre-frequency holding time set by F3-03, and then automatically get into wobble frequency run.

1: Started by terminal

Digital input terminal "start wobble frequency" controls the run of wobble frequency. When terminal inputs ON, the drive gets into wobble frequency run. When terminal inputs OFF, the drive exits wobble frequency and runs at pre-frequency of wobble frequency. Under this mode, Pre-frequency holding time is enabled.

◆ Tens place: amplitude control

0: Relative to center frequency

Amplitude = F3-04 x current frequency setting.

1: Relative to maximum frequency

Amplitude = F3-04 x maximum frequency b0-08.

◆ Hundreds place: wobble frequency memorized when stop

0: Memory enabled

The drive memorizes the current wobble frequency state when stop. When restarted, drive continues to run the wobble frequency with the memorized state at latest stop. Pre-frequency of wobble frequency F3-02 is enabled at restart.

1: Memory disabled

When the drive is started, it restarts wobble frequency running. Run at pre-frequency of wobble frequency F3-02, maintain this frequency for pre-frequency holding time F3-03, and then automatically gets into wobble frequency control.

◆ Thousands place: wobble frequency memorized on power loss

0: Memory enabled

Automatically save the wobble frequency state on power loss. This function takes effect only under wobble frequency running.

1: Memory disabled

Drive clears wobble frequency status on power loss.

F3-02	Pre-wobble frequency	Range: 0.00Hz~600.00Hz	Factory default: 0.00Hz
F3-03	Pre-wobble frequency holding time	Range: 0.0s~3600.0s	Factory default: 0.0s

During the run of wobble frequency, F3-02 is the run frequency before the drive begins to run at wobble frequency, while F3-03 is the holding time of pre-wobble frequency. When F3-03 is set to 0, pre-frequency is disabled.

F3-04	Wobble frequency amplitude	Range: 0.0%~50.0%	Factory default: 0.0%
-------	----------------------------	-------------------	--------------------------

The percentage is relative to center frequency or maximum frequency and determined by the tens place of F3-01. Center frequency is the frequency setting determined by parameters of Group b0.

Run frequency of wobble frequency is not only subject to this amplitude, but is also restricted by upper limit and lower limit of frequency.

F3-05	Hop frequency	Range: 0.0%~50.0%	Factory default: 0.0%
-------	---------------	-------------------	--------------------------

Hop frequency = F3-05 × amplitude.

F3-06	Cycle of wobble frequency	Range: 0.1s~999.9s	Factory default: 0.0s
-------	---------------------------	--------------------	--------------------------

The time of the completion of a complete process of wobble frequency

F3-07	Triangular wave ramp-up time	Range: 0.0%~100.0%	Factory default: 0.0%
-------	------------------------------	--------------------	--------------------------

Sets the wobble frequency run time of ramp-up step.

Triangular wave ramp up time = F3-07 × F3-06

Wobble frequency ramp-down time = F3-06 - triangular wave ramp-up time

ATTENTION:

The current wobble frequency status can be cleared by digital input terminal "clear wobble frequency status " in stop status.If the output frequency exceeds upper limit frequency or lower limit frequency during the running at wobble frequency, digital output terminal " wobble frequency attains to upper or lower limit frequency " outputs ON signal

Parameters F3-08~F3-11 are for fixed-length stop.

F3-08	Length unit	Range: 0~1	Factory default: 0
-------	-------------	------------	--------------------

0: m

1: 10m

F3-09	Length setting	Range: 0~65535	Factory default: 1000
-------	----------------	----------------	--------------------------

Sets the length value of fixed-length stop. When set to 0, fixed-length stop function is enabled, but the actual length is still calculated. When it is detected the actual length attains this set value, digital output terminal "length attained" will output ON signal and perform the command set by F3-11.

F3-10	Pulse number per meter	Range: 0.1~6553.5	Factory default: 100.0
-------	------------------------	-------------------	---------------------------

Input pulse is received via digital input terminal "length count"; the pulse number per meter is set here.

F3-11	Action when the length attained	Range: 0~1	Factory default: 0
-------	---------------------------------	------------	--------------------

0: Not stop

1: Stop

This parameter sets the action of the drive when actual length attains the length set by F3-09. Actual length can be cleared through digital input terminal "length clear".

ATTENTION:

When actual length is detected to attain the set length, digital output terminal "length attained" outputs ON signal no matter the drive is set to stop or not stop. Actual length is saved at power loss and can be read in both stop and running.

F3-12	Set count value	Range: 1~65535	Factory default: 1000
F3-13	Designated count value	Range: 1~65535	Factory default: 1000

The two parameters are used with digital input terminal "count input" and digital output terminals "set count value attained" and "designated count value attained". Input pulse through digital input terminal "count input". When the number of pulses attain the value set by F3-12, the terminal outputs ON. With the completion of the value of F3-12, the terminal "designated count value attained" outputs OFF.

When the number of input pulses attains the designated count value of F3-13, terminal "designated count value attained" will output ON. Upon the completion of set count value of F3-12, terminal "designated count value attained" outputs OFF.

For example: F3-12= 10, F3-13= 7. Fig. 6-56:

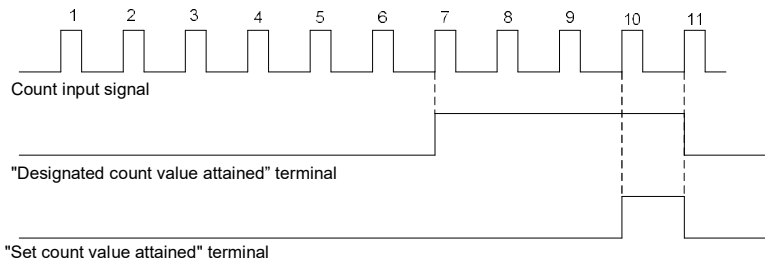

Fig. 6-56

ATTENTION:

Actual count value can be cleared through digital input terminal "count clear". Actual count value is saved at power loss.

Group F5 Wobble Frequency and Fixed Length Count

F5-00	Recognition of rotor initial magnetic pole position	Range: 0~2	Factory default: 0
-------	---	------------	--------------------

0: Detecting forbidden

1: Recognition of pulse injection initial position

This setting is suitable for PMSM with certain salient pole ratio. If F5-00 is set to 1, there will be no obvious reverse slip or rotating when motor is starting, but there will be sound of pulse injection at starting moment. It is suitable for application which allow zero-reverse when motor is starting.

2. Reserved

F5-04	Initial pull-in current	Range: 0.0%~200.0%	Factory default: 50.0%
F5-05	Cut-off FREQ of pull-in current	Range: 0.00Hz~b0-09	Factory default: 0.00Hz

Parameter F5-04 and F5-05 can be properly increased when there is difficulty in motor starting. When Frequency is less than F5-05, PMSM will run with constant torque at F5-04 of rated current.

F5-09	Max. torque current ratio coefficient	Range: 0.000~32.000	Factory default: 0.000
-------	---------------------------------------	---------------------	---------------------------

0: forbid Max. torque current ratio (MTPA) control

Not 0: Max. torque current ratio (MTPA) coefficient

The coefficient is inversely proportional to salient pole ratio, the higher the salient ratio is, the smaller this coefficient should be set to.

ATTENTION:

When PMSM SVC is adopted (A0-09=3), it is NOT recommended to use MTPA control. This has a high requirement for Q-axis and D-axis inductance and back EMF coefficient, and may easily affect system stability.

F5-12	Speed observer bandwidth coefficient	Range: 0.000~32.000	Factory default: 4.000
F5-13	Speed observer filter coefficient	Range: 0.000~32.000	Factory default: 0.200

Bandwidth and filter coefficient of PMSM rotor speed observer, normally there is no need to change default setting

F5-17	Open-loop vector mode selection	Range: 0~1111	Factory default: 0011
-------	---------------------------------	---------------	--------------------------

◆ Ones place: dead-time compensating enabled

0: Forbidden

1: Enabled

If it is set to 1, AC drive will enable dead-time compensating, then harmonic distortion rate of output current will decrease, and torque pulse will decrease.

◆ Tens place: feedforward control enabled

0: Forbidden

1: Enabled

If it is set to 1, cross coupling will be brought in for PMSM current control inner circuit, and system dynamic response ability will be increased.

- ◆ Hundreds place: start step-out self-recovery enabled

0: Forbidden

1: Enabled

If it is set to 1, PMSM will recover and start again after start step-out.

- ◆ Thousands place: speed loop integral separating enabled

0: Forbid integral separating

1: Enable integral separating

It can be enabled for large-inertia application

Following F5-20~F5-25 is specification for PMSM flux weakening loop parameter

F5-20	Max. flux weakening current allowed	-8000~8000	Factory default: -6000
-------	-------------------------------------	------------	------------------------

F5-20 is scale value of max. flux weakening current allowed, actual corresponding current is indicated as $d0-03 * F5-20 / 4096$. Adjust this parameter to limit PMSM flux weakening current.

F5-21	Max. voltage utilization ratio	Range: 0~65535	Factory default: 31767
-------	--------------------------------	----------------	------------------------

F5-21 is scale value of max. voltage utilization ratio, actual max. voltage utilization value is indicated as $F5-21 / 32767$. Adjust this parameter to adjust voltage utilization and output max. voltage limit of AC drive. This parameter is invalid if over modulation function is enabled (hundreds place of E0-01 is set to 1).

F5-24	Flux weakening loop proportional gain	Range: 0~65535	Factory default: 0
F5-25	Flux weakening loop integral gain	Range: 0~65535	Factory default: 800

F5-24 and F5-25 is proportional gain and integral gain coefficient of flux weakening loop. Normally there is no need to change default setting.

Group H Communication Parameters

Group H0 MODBUS Communication Parameters

Support universal Modbus protocol. Please refer to appendix for detailed description of communication protocol.

H0-00	SCI port selection	Range: 0~1	Factory default: 0
-------	--------------------	------------	--------------------

0: Local 485 port

1: Optional 232 port

H0-01	SCI port communication configuration	Range: 0000~1155	Factory default: 0001
-------	--------------------------------------	------------------	-----------------------

◆ Ones place: baud rate

- 0: 4800bps
- 1: 9600bps
- 2: 19200bps
- 3: 38400bps
- 4: 57600bps
- 5: 115200bps

◆ Tens place: data format

- 0: 1-8-2-N format, RTU
- 1: 1-8-1-E format, RTU
- 2: 1-8-1-O format, RTU
- 3: 1-7-2-N format, ASCII
- 4: 1-7-1-E format, ASCII
- 5: 1-7-1-O format, ASCII

◆ Hundreds place: connection type

- 0: Direct cable connection (232/485)
- 1: MODEM (232) (reserved)

◆ Thousands place: communication data handling at power loss

- 0: Saved at power loss
- 1: Not saved at power loss

H0-02	Local address of SCI port communication	Range: 0~247	Factory default: 5
-------	---	--------------	--------------------

Sets the local address. 0 is broadcast address, while available addresses are 1~247.

H0-03	Time out detection of SCI port communication	Range: 0.0s~1000.0s	Factory default: 0.0s
-------	--	---------------------	-----------------------

This parameter sets communication error detection time. When it's set to 0, no communication error will be reported.

H0-04	Time delay of SCI port communication	Range: 0ms~1000ms	Factory default: 0ms
-------	--------------------------------------	-------------------	----------------------

Sets time delay of this drive response to the master.

H0-05	Master/Slave option	Range: 0~2	Factory default: 0
-------	---------------------	------------	--------------------

0: PC controls this drive

PC as master controls this drive. This supports all communication protocols.

1: As master

According to the selection of H0-06, the drive sends current b0-02 (digital setting of master frequency) or F0-01 (PID digital setting) through communication. As master, this drive can only send the data and cannot receive the data.

2: As slave

Put the received data into b0-02 (digital setting of master frequency) or F0-01 (PID digital setting) through communication. b0-02/F0-01 is selected by parameter H0-06. Other communication data addresses are not supported. As slave, this drive can only receive the data.

H0-06	Frequency setting address when master controlling slave	Range: 0~1	Factory default: 0
-------	---	------------	--------------------

0: b0-02

1: F0-01

This parameter takes effect when H0-05 is set to 1. This parameter sets the slave drive frequency setting address when this drive is working as the master drive.

H0-07	Proportional factor of received frequency	Range: 0.0~1000.0%	Factory default: 100.0%
-------	---	--------------------	-------------------------

This parameter takes effect when H0-05 is set to 2. Data sent by master is multiplied by H0-07 and then put the result into b0-02 or F0-01 (set by H0-06 of master).

This parameter setting is very useful when a master drive controls a number of slave drives and needs to allocate the frequency.

Group H1 Profibus-DP communication parameters

Refer to *EPC-CM2 Instruction Manual* for details

Group L Keys and Display of Control Panel

Group L0 Keys of Control Panel

L0-00	MF key setting	Range: 0~6	Factory default: 0
-------	----------------	------------	--------------------

0: No function

1: Forward jog

2: Reverse jog

3: Forward/reverse switchover

4: Emergency stop 1 (set Decel time by b2-09)

5: Emergency stop 2 (coast to stop)

6: Run command sources shifted (control panel/terminal/communication)

L0-01	Keys locked option	Range: 0~4	Factory default: 0
-------	--------------------	------------	--------------------

0: Not locked

1: All locked

2: Keys locked except RUN, STOP/RESET

3: Keys locked except STOP/RESET

4: Keys locked except >>

Please refer to Chapter 4 for locking operation of keys.

L0-02	Function of STOP key	Range: 0~1	Factory default: 0
-------	----------------------	------------	--------------------

0: STOP key active only at control panel control

1: STOP key deactivated under any command source

L0-03	Frequency adjustment through keys \wedge/\vee	Range: 0000~1111	Factory default: 0100
-------	---	------------------	-----------------------

◆ Ones place: option at stop

0: Clear at stop

Keys \wedge/\vee frequency adjustment step size is cleared at the stop of drive.

1: Holding at stop

Keys \wedge/\vee frequency adjustment step size is held at the stop of drive.

◆ Tens place: option at power loss

0: Clear at power loss

Keys \wedge/\vee frequency adjustment step size is cleared at power loss.

1: Holding at power loss

Keys \wedge/\vee frequency adjustment step size is saved at power loss.

◆ Hundreds place: integrating option

0: Integrating disabled

Adjustment step size is kept constant when frequency is adjusted by keys \wedge/\vee , and the adjustment will be performed always with the step size set by L0-04.

1: Integrating enabled

When frequency is adjusted by keys \wedge/\vee , the initial step size is the set value of L0-04. With the press increase of \wedge/\vee , adjustment step size shows cumulative integrating effect and will increase gradually.

◆ Thousands place: run direction

0: Direction changing prohibited

When the frequency is decreased to 0Hz by terminal UP/DOWN, the drive will run at 0Hz and cannot be able to change the rotary direction.

1: Direction changing permitted

When the frequency is decreased to 0Hz by terminal UP/DOWN, the drive continues to decrease its out frequency and change the motor rotary direction.

L0-04	Step size of frequency adjustment through keys \wedge/\vee	Range: 0.00Hz/s~10.00Hz/s	Factory default: 0.03 Hz/s
-------	--	------------------------------	-------------------------------

When frequency setting is "digital setting + control panel \wedge/\vee adjustment", progressive increase and decrease of frequency setting is realized through \wedge or \vee on control panel. This parameter is used to set the step size of frequency adjustment through \wedge/\vee . The step size is defined as frequency variation per second, and the smallest step size is 0.01 Hz/s.

Group L1 Control Panel Display Setting

L1-00	Display parameter setting 1 on run status	Range: 0000~3FFF	Factory default: 080F
-------	---	------------------	--------------------------

Sets LED displayed parameters on run status. When a number of parameters are selected to be displayed, skim-through could be performed using key >> on control panel.

0: No display

1: Display

◆ Ones place

BIT0: Run frequency (Hz)

BIT1: Set frequency (Hz)

BIT2: Bus voltage (V)

BIT3: Output current (A)

◆ Tens place

BIT0: Output torque (%)

BIT1: Output power (kW)

BIT2: Output voltage (V)

BIT3: Motor speed (r/min)

◆ Hundreds place

BIT0: AI1 (V)

BIT1: AI2 (V)

BIT2: EAI (V)

BIT3: Output sync frequency (Hz)

◆ Thousands place

BIT0: DI

BIT1: External count value

BIT2: Reserved

BIT3: Reserved

 **ATTENTION:**

When this parameter value is set to 0000, run frequency (Hz) would be displayed as default.

Example:

To display run frequency, output current, motor speed and AI1 sampled value, L1-00 should be: 0000 0001 1000 1001, i.e. set L1-00 to 0189.

L1-01	Display parameter setting 2 on run status	Range: 0000~00FF	Factory default: 0000
-------	--	------------------	--------------------------

0: No display

1: Display

◆ Ones place

BIT0: Run linear speed (m/s)

BIT1: Set linear speed (m/s)

BIT2: Input terminal status

BIT3: Output terminal status

◆ Tens place

BIT0: PID setting (%)

BIT1: PID feedback (%)

BIT2: Set length (m)

BIT3: Actual length (m)

◆ Hundreds place: Reserved

◆ Thousands place: Reserved

L1-02	Display parameter setting on stop status	Range: 0000~FF7F	Factory default: 0003
-------	---	------------------	--------------------------

Sets LED displayed parameters on stop status. When a number of parameters are selected, skim-through could be realized via key >> on control panel.

0: No display

1: Display

◆ Ones place

BIT0: Frequency setting (Hz)

BIT1: Bus voltage (V)

BIT2: Input terminal status

BIT3: Output terminal status

◆ Tens place

BIT0: AI1 (V)

BIT1: AI2 (V)

BIT2: EAI (V)

BIT3: Reserved

◆ Hundreds place

BIT0: PID setting (%)

BIT1: PID feedback (%)

BIT2: Set length (m)

BIT3: Actual length (m)

◆ Thousands place

BIT0: Run linear speed (m/s)

BIT1: Set linear speed (m/s)

BIT2: External count value

BIT3: DI

Note: when this parameter is set to 0000, the set frequency would be displayed as default (Hz).

Example:

To display frequency setting, bus voltage, AI1 sampled value, set length and external count value, L1-02 should be: 0100 0100 0001 0011, i.e. set L1-02 to 4413.

L1-03	Linear speed coeff	Range: 0.1%~999.9%	Factory default: 100.0%
-------	--------------------	--------------------	----------------------------

This coefficient is used for calculation of linear speed.

Run linear speed = motor run speed x L1-03

Set linear speed = motor speed setting x L1-03

Both run linear speed and set linear speed can be viewed during the run and stop.

Group U Monitoring

Group U0 Status Monitoring

All parameters of Group U0 are for display purpose only and can't be programmed.

U0-00	Run frequency	Range: 0.00Hz~600.00Hz	Factory default: 0.00Hz
U0-01	Set frequency	Range: 0.00Hz~600.00Hz	Factory default: 0.00Hz
U0-02	Bus voltage	Range: 0V~65535V	Factory default: 0V
U0-03	Output voltage	Range: 0V~65535V	Factory default: 0V
U0-04	Output current	Range: 0.0A~6553.5A	Factory default: 0.0A
U0-05	Output torque	Range: -300.0%~300.0%	Factory default: 0.0%
U0-06	Output power	Range: 0.0%~300.0%	Factory default: 0.0%
U0-07	Master FREQ set source	Range: 0~9	Factory default: 0

U0-08	Auxiliary FREQ set source	Range: 0~10	Factory default: 0
U0-09	Master frequency setting	Range: 0.00Hz~600.00Hz	Factory default: 0.00Hz
U0-10	Auxiliary frequency setting	Range: 0.00Hz~600.00Hz	Factory default: 0.00Hz
U0-11	Drive status	Range: 0~22	Factory default: 00

◆ Ones place: Running status

0: Accelerating

1: Decelerating

2: Constant speed running

◆ Tens place: drive status

0: Stop

1: Running status

2: Motor parameters are being identified

U0-12	AI1 input voltage	Range: 0.00V~10.00V	Factory default: 0.00V
U0-13	AI2 input voltage	Range: -10.00V~10.00V	Factory default: 0.00V
U0-14	EAI input voltage	Range: 0.00V~10.00V	Factory default: 0.00V
U0-15	AO1 output	Range: 0.0%~100.0%	Factory default: 0.0%
U0-16	EAO output	Range: 0.0%~100.0%	Factory default: 0.0%
U0-17	X6/DI HF pulse frequency	Range: 0.0kHz~50.0kHz	Factory default: 0.0kHz
U0-18	Digital input terminal status	Range: 00~7F	Factory default: 00

Digital input terminals that correspond to the bits of U0-18 are as shown in Table 6-19:

Table 6-19

Tens place			Ones place			
bit6	bit5	bit4	bit3	bit2	bit1	bit0
EX	X6	X5	X4	X3	X2	X1

0 means terminal input status is OFF, while 1 means terminal input status is ON.

For example:

If 23 (i.e. 0010 0011) is displayed at U0-18, it means the input status of terminals X1, X2 and X6 is ON and that of the other terminals is OFF.

If 05 (i.e. 0000 0101) is displayed at U0-18, it means the input status of terminals X1 and X3 is ON while that of the other terminals is OFF.

U0-19	Digital output terminal status	Range: 0~7	Factory default: 0
-------	--------------------------------	------------	--------------------

Corresponding relationship between digital output terminals and the bits of U0-19 is shown in Table 6-20:

Table 6-20

bit3	bit2	bit1	bit0
Option board relay	Control board relay	Y2	Y1

0 means terminal output status is OFF, while 1 means terminal output status is ON.

For example:

If 6 (i.e. 0110) is displayed at U0-19, it means the output status of terminals Y2 and control board relay is ON while that of the other terminals is OFF.

U0-20	PID set	Range: 0.0%~100.0%	Factory default: 0.0%
U0-21	PID feedback	Range: 0.0%~100.0%	Factory default: 0.0%
U0-22	PID input offset	Range: -100.0%~100.0%	Factory default: 0.0%
U0-23	PLC step	Range: 0~15	Factory default: 0
U0-24	V/f separated target voltage	Range: 0.0%~100.0%	Factory default: 0.0%
U0-25	V/f separated actual output voltage	Range: 0.0%~100.0%	Factory default: 0.0%
U0-30	Cumulative power-up time	Range: 0h~65535h	Factory default: 0h
U0-31	Cumulative run time	Range: 0h~65535h	Factory default: 0h
U0-32	Heat sink temperature 1	Range: -40.0℃~100.0℃	Factory default: 0.0℃

U0-33	Heat sink temperature 2	Range: -40.0°C~100.0°C	Factory default: 0.0°C
-------	-------------------------	------------------------	---------------------------

U0-34	U0-34	Range: 0~6	Factory default: 0
-------	-------	------------	--------------------

When the drive reports fault "FAL", the fault source can be known by U0-34.

- 0: No fault source
- 1: IGBT overcurrent
- 2: Reserved
- 3: Output grounding fault
- 4: Output overcurrent
- 5: DC bus overvoltage
- 6: Other sources

U0-35	Terminal count value	Range: 0~65535	Factory default: 0
U0-36	Run command log at LoU	Range: 0~1	Factory default: 0
U0-37	Fault code log at LoU	Range: 0~100	Factory default: 0
U0-38	Reserved	Reserved	Reserved
U0-39	CtC fault source	Range: 0~3	Factory default: 0

- 0: No fault
- 1: U-phase current detection circuit fault
- 2: V-phase current detection circuit fault
- 3: W-phase current detection circuit fault

U0-40	Higher-bit numbers of actual length	Range: 0~65	Factory default: 0
U0-41	Lower-bit numbers of actual length	Range: 0~65535	Factory default: 0
U0-42	Higher-bit numbers of control panel \wedge/\vee stored value	Range: -1~1	Factory default: 0
U0-43	Lower-bit numbers of control panel \wedge/\vee stored value	Range: 0.00~655.35Hz	Factory default: 0.00Hz
U0-44	Higher-bit numbers of terminal UP/DOWN stored value	Range: -1~1	Factory default: 0
U0-45	Lower-bit numbers of terminal UP/DOWN stored value	Range: 0.00~655.35 Hz	Factory default: 0.00Hz

U0-52	Center FREQ of wobble FREQ	Range: 0~600.00 Hz	Factory default: 0.00 Hz
U0-53	Initial position angle	Range: 0.0~6000.0	Factory default: 0.0

Group U1 History Fault

U1-00	History fault 1 (latest)	Range: 0~47	Factory default: 0
U1-01	Run frequency at fault 1	Range: 0.00Hz~600.00Hz	Factory default: 0.00Hz
U1-02	Output current at fault 1	Range: 0.0A~6553.5A	Factory default: 0.0A
U1-03	Bus voltage at fault 1	Range: 0V~10000V	Factory default: 0V
U1-04	Temperature 1 of heat sink at fault 1	Range: -40.0°C~100.0°C	Factory default: 0.0°C
U1-05	Temperature 2 of heat sink at fault 1	Range: -40.0°C~100.0°C	Factory default: 0.0°C
U1-06	Input terminal status at fault 1	Range: 0000~FFFF	Factory default: 0000
U1-07	Output terminal status at fault 1	Range: 0000~FFFF	Factory default: 0000
U1-08	Cumulative run time at fault 1	Range: 0h~65535h	Factory default: 0h

Check the information of the latest fault. See Chapter 7 for details of fault codes.

U1-09	Code of fault 2	Range: 0~47	Factory default: 0
U1-10	Run frequency at fault 2	Range: 0.00Hz~600.00Hz	Factory default: 0.00Hz
U1-11	Output current at fault 2	Range: 0.0A~6553.5A	Factory default: 0.0A
U1-12	Bus voltage at fault 2	Range: 0V~10000V	Factory default: 0V
U1-13	Temperature 1 of heat sink at fault 2	Range: -40.0°C~100.0°C	Factory default: 0.0°C
U1-14	Temperature 2 of heat sink at fault 2	Range: -40.0°C~100.0°C	Factory default: 0.0°C
U1-15	Input terminal status at fault 2	Range: 0000~FFFF	Factory default: 0000
U1-16	Output terminal status at fault 2	Range: 0000~FFFF	Factory default: 0000
U1-17	Cumulative run time at fault 2	Range: 0h~65535h	Factory default: 0h

Check the information of previous fault 1. See Chapter 7 for details of fault codes.

U1-18	Code of fault 3	Range: 0~47	Factory default: 0
U1-19	Run frequency at fault 3	Range: 0.00Hz~600.00Hz	Factory default: 0.00Hz
U1-20	Output current at fault 3	Range: 0.0A~6553.5A	Factory default: 0.0A
U1-21	Bus voltage at fault 3	Range: 0V~10000V	Factory default: 0V
U1-22	Temperature 1 of heat sink at fault 3	Range: -40.0°C~100.0°C	Factory default: 0.0°C
U1-23	Temperature 2 of heat sink at fault 3	Range: -40.0°C~100.0°C	Factory default: 0.0°C
U1-24	Input terminal status at fault 3	Range: 0000~FFFF	Factory default: 0000
U1-25	Output terminal status at fault 3	Range: 0000~FFFF	Factory default: 0000
U1-26	Cumulative run time at fault 3	Range: 0h~65535h	Factory default: 0h

The recorded fault sequence: fault 3, fault 2, fault 1. See Chapter 7 for details of fault codes.

Chapter 7 Troubleshooting

7.1 Fault Causes and Troubleshooting

Once drive fault occurs, please identify the causes of fault carefully and make a detailed record of fault symptom. To seek services, please contact the dealer. Parameters U1-00, U1-09 and U1-18 are used to view the records of fault 1, fault 2 and fault 3. Faults are recorded with numeric codes (1~46), while the fault information that corresponds to each numeric fault code is specified in the table below.

Table of Fault Codes

Fault code	Fault display	Fault description	Causes	Solutions
1	oC1	Accel overcurrent	Torque boost is too big under V/f control	Reduce torque boost value
			Start frequency is too high	Drop start frequency
			Accel time is too short	Prolong the Accel time
			Motor parameters are improperly set	Set the parameters correctly according to motor nameplate
			Output short circuit (phase-to-phase short circuit or output ground short circuit)	Check motor connection and output ground impedance
			Overload is too heavy	Reduce the load
			Inappropriate V/f curve under V/f control	Set V/f curve correctly
			Restart the rotating motor	Reduce current limited value or flying start
2	oC2	Canst-speed overcurrent	Output short circuit (phase-to-phase short circuit or output ground short circuit)	Check motor connection and output ground impedance
			Overload is too heavy	Reduce the load
			Power rating of the drive is relatively small	Select appropriate drive power rating
			Input voltage is too low	Check power grid voltage

Fault code	Fault display	Fault description	Causes	Solutions
3	oC3	Decel overcurrent	Output short circuit (phase-to-phase short circuit or output ground short circuit)	Check motor connection and output ground impedance
			Load inertia is too big	Use dynamic brake
			Decel time is too short	Prolong the Decel time
			Input voltage is too low	Check power grid voltage
4	ov1	Accel overvoltage	Load inertia is too big	Use dynamic brake
			Abnormal input voltage	Check power grid voltage
			Output short circuit (phase-to-phase short circuit or output ground short circuit)	Check motor connection and output ground impedance
5	ov2	Constant-speed overvoltage	Load variation is too big	Check the load
			Abnormal input voltage	Check power grid voltage
			Output short circuit (phase-to-phase short circuit or output ground short circuit)	Check motor connection and output ground impedance
			Improper parameter setting of regulator under SVC control	Properly set regulator parameters
6	ov3	Decel overvoltage	Load inertia is too big	Use dynamic braking
			Abnormal input voltage	Check power grid voltage
			Output short circuit (phase-to-phase short circuit or output ground short circuit)	Check motor connection and output ground impedance
			Improper parameter setting of regulator under SVC control	Properly set regulator parameters
			Decel time is too short	Prolong the Decel time

Fault code	Fault display	Fault description	Causes	Solutions
7	FAL	Module protection	Overvoltage or overcurrent	Refer to the solutions of overvoltage or overcurrent
			Output short circuit (phase-to-phase short circuit or output ground short circuit)	Check motor connection and output ground impedance
			Loose connection of control board	Pull out and reinsert the cables of control board
			Direct connection of inverter module	Seek services
			Control board abnormal	Seek services
			Switching power supply failed	Seek services
8	tUN	Autotuning failed	Bad motor connection	Check motor connection
			Autotuning during rotation of the motor	Autotuning in stationary status of the motor
			Big error between real motor parameters and the setting	Set the parameters correctly according to motor nameplate
9	oL1	Drive overloaded	Torque boost is too big under V/f control	Reduce torque boost value
			Start FREQ is too high	Drop start frequency
			Accel/Decel time is too short	Prolong the Accel/Decel time
			Motor parameters are improperly set	Set the parameters correctly according to motor nameplate
			Output short circuit (phase-to-phase short circuit and output ground short circuit)	Check motor connection and output ground impedance
			Load is too heavy	Reduce the load
			Inappropriate V/f curve under V/f control	Set V/f curve correctly
			Restart the rotary motor	Reduce current limited value or flying start

Fault code	Fault display	Fault description	Causes	Solutions
10	oL2	Motor overloaded	Torque boost is too big under V/f control	Reduce torque boost value
			Inappropriate V/f curve under V/f control	Set V/f curve correctly
			Motor parameters are improperly set	Set the parameters correctly according to motor nameplate
			Improper setting of motor overloaded protection time	Properly set the motor overloaded protection time
			Motor stalled or sharp variation of load	Identify the causes of motor stalling or check the load condition
			Long-time running of ordinary motor at low speed with heavy load	Select variable frequency motor
11	CtC	Current detection abnormal	Abnormal connection between control board and drive board	Check and re-connection
			Abnormal current detection circuit of control board	Seek services
			Abnormal current detection circuit of drive board	Seek services
			Current sensor failed	Seek services
			SMPS failed	Seek services
12	GdP	Output ground short-circuit protection	Output connection ground short circuit	Check motor connection and output ground impedance
			Motor insulation abnormal	Check the motor
			Inverter module abnormal	Seek services
			Output ground leakage current is too big	Seek services

Fault code	Fault display	Fault description	Causes	Solutions
13	ISF	Input power supply abnormal	Severe voltage imbalance among power supply phases	Check power grid voltage
			Abnormal input wiring of power supply	Check power supply input wiring
			Abnormal bus capacitance	Seek services
14	oPL	Output phase loss	Motor cable connection abnormal	Check motor connection
			Imbalance among motor three phases	Check or replace the motor
			Incorrect setting of vector control parameters	Correctly set vector control parameters
15	oL3	Inverter module overload protection	Overcurrent	Handle it with the methods for overcurrent
			Input power supply abnormal	Check input power grid voltage
			Motor output abnormal	Check the motor or motor connection
			Inverter module abnormal	Seek services
16	oH1	Module (IGBT) thermal protection	Ambient temperature is too high	Drop ambient temperature
			Fan failed	Replace the fan
			Air duct blocked	Clear air duct
			Temperature sensor abnormal	Seek services
			Inverter module mounting abnormal	Seek services
17	oH2	Motor (PTC) thermal protection	Ambient temperature is too high	Drop ambient temperature
			Improper setting of motor thermal protection point	Correctly set motor thermal protection point
			Thermal detection circuit failed	Seek services

Fault code	Fault display	Fault description	Causes	Solutions
18	oH3	Module temperature detection disconnected	Temperature sensor not well connected with socket	Pull out and re-insert
			Ambient temperature is too low	Raise ambient temperature
			Module detection circuit failed	Seek services
			Thermistor failed	Seek services
20	EC1	Option board connection abnormal	Loose or poor option board connection	Pull out and reinsert
			Option board abnormal	Seek services
			Control board abnormal	Seek services
22	dLC	Abnormal flat cable connection of control board	Loose or poor drive line connection	Pull out and re-insert after complete power off
			Drive board abnormal	Seek services
			Control board abnormal	Seek services
23	TEr	Function conflict between analog terminals	Analog input terminals are set to the same function	Do not set analog inputs to the same function
24	PEr	External equipment error	External fault terminal is enabled	Check the status of external fault terminal
			Stall condition lasts too long	Check if the load is abnormal
26	to2	Consecutive run time attained	"Consecutive run time attained" enabled	See specification of Group E0
27	to3	Cumulative run time attained	"Cumulative run time attained" enabled	See specification of Group E0
28	SUE	Power supply abnormal at run	DC bus voltage fluctuation is too big or the power is lost	Check input power grid voltage and load

Fault code	Fault display	Fault description	Causes	Solutions
29	EPr	EEPROM read/write fault	Parameter read/write abnormal at control board	Seek services
30	CCL	Contactor close fault	Power supply voltage abnormal	Check grid power supply voltage
			Abnormal contactor feedback circuit at drive board	Seek services
			Contactor failed	Seek services
			Buffer resistance failed	Seek services
			Abnormal SMPS	Seek services
31	TrC	Port communication abnormal	Improper setting of baud rate	Set properly
			Communication port disconnected	Reconnected
			Upper computer/device does not work	Make upper computer/device work
			Drive communication parameter error	Set properly
32	PdC	Control panel communication abnormal	Control panel disconnected	Reconnected
			Severe EMI	Check peripheral equipment or seek services
33	CPy	Parameter copy failure	Parameter uploading or downloading abnormal	Seek services
			No parameters stored at control panel	Seek services
35	SFt	Software version compatibility failure	Version of control panel is not consistent with that of control board	Seek services
36	CPU	Abnormal power loss	Abnormal power loss in last operation	RESET the fault
			Faulty control board	Seek services

Fault code	Fault display	Fault description	Causes	Solutions
37	oCr	Overcurrent benchmark error	SMPS failed	Seek services
			Control board failed	Seek services
38	SP1	5V supply out-of-limit	SMPS failed	Seek services
			Control board failed	Seek services
39	SP2	10V supply out-of-limit	SMPS failed	Seek services
			Control board failed	Seek services
40	AIP	AI input out-of-limit	Control board failed	Seek services
			AI input is too high or low	Set AI input within correct range
41	LoU	Undervoltage protection	DC bus voltage is too low	Check input voltage if it is too low or the drive is the process of power loss
45	Plo	PID feedback lost	Abnormal PID feedback channel	Check the feedback channel
			Inappropriate setting of PID parameters	Set properly
46	PFS	Abnormal Profibus communication	Communication wiring problem	Rewiring
			Severe ambient EMI	Check peripheral equipment or seek services
47	bEF	Abnormal back EMF	Controlled motor is not PMSM	Confirm motor type
			PM demagnetization of PMSM	Replace motor

 **ATTENTION:**

When a fault occurs, please identify the causes and seek solutions according to the guidance in the table. If the fault fails to be solved, do not apply power to the drive again. Contact the supplier for service in time.

Chapter 8 Maintenance

Ambient temperature, humidity, salt mist, dust, vibration, aging and wear of internal components may result in drive faults. Routine maintenance shall be performed during the use and storage.

 **ATTENTION:**

Please make sure the power supply of the drive has been cut off, and DC bus voltage has discharged to 0V before the maintenance.

8.1 Routine Inspection

Please use the drive in the environment recommended by this manual, and perform routine inspection in accordance with the table below.

Inspection items	Inspection aspects	Inspection methods	Criteria
Operating environment	Temperature	Thermometer	-10°C~50°C
	Humidity	Hygrometer	5%~95%, condensation not allowed
	Dust, oil stains, moisture and water-drop	Visual inspection	No filthy mud, oil stains and water drop
	Vibration	Observation	Smooth running. No abnormal vibration
	Gas	Smell, visual inspection	No peculiar smell and abnormal smoke
Drive	Noise	Listen	No abnormal noise
	Gas	Smell, visual inspection	No peculiar smell and abnormal smoke
	Appearance	Visual inspection	No defect and deformation
	Heat dissipation and temperature rise	Visual inspection	No dust and/or fiber particles in air duct, normal working of fans, normal air speed and volume, no abnormal temperature rise

Inspection items	Inspection aspects	Inspection methods	Criteria
Motor	Thermal status	Smell	No abnormal heating and scorching smell
	Noise	Listen	No abnormal noise
	Vibration	Observe, listen	No abnormal vibration and sound
Running status parameters	Power supply input current	Ammeter	In the range of requirement
	Power supply input voltage	Voltmeter	In the range of requirement
	Drive output current	Ammeter	In the range of requirement
	Drive output voltage	Voltmeter	In the range of requirement
	Temperature	Thermometer	The difference between U0-33 displayed temperature and ambient temperature does not exceed 40°C

8.2 Regular Maintenance

Users should perform regular inspection of the drive every 3~6 months, so as to eliminate the potential faults.

ATTENTION:

Please make sure power supply of the drive has been cut off, and DC bus voltage has been discharged to 0V prior to maintenance. Never leave screws, gaskets, conductors, tools and other metal articles inside the drive. Failure to comply may result in equipment damage. Never modify the interior components of the drive in any condition. Failure to comply may result in equipment damage.

Inspection items	Measures
Check if control terminal screws are loose	Tighten
Check if main circuit terminal screws are loose	Tighten
Check if ground terminal screws are loose	Tighten
Check if copper bar screws are loose	Tighten
Check if drive mounting screws are loose	Tighten

Inspection items	Measures
Check if there are defect on power cables and control cables	Replace the cables
Check if there is dust on circuit board	Clear it up
Check if air duct is blocked	Clear it up
Check if drive insulation is failed	Test the ground terminal with 500V megameter after all input and output terminals are short-circuited via conductors. Ground test on individual terminals is strictly prohibited since this may cause damage to inverter.
Check if motor insulation is failed	Remove input terminals U/V/W of motor from drive and test the motor alone with 500V megameter. Failure to comply may result in drive failure.
Check if the storage period of the drive is over two years	Carry out power-on test, during which, the voltage should be boosted to rated value gradually using a voltage regulator; be sure to run at no load for more than 5 hours.

8.3 Replacement of Vulnerable Parts

Vulnerable parts of drive include cooling fan, electrolytic capacitor, relay or contactor etc. The service lives of these parts are subject to environment and working conditions. To maintain a favorable operating environment is conducive to improving the service life of parts and components; routine inspection and maintenance also contributes to effective improvement of parts' service life. To prolong the service life of entire drive, the cooling fan, electrolytic capacitor, relay or contactor and other vulnerable parts should be subjected to routine inspection according to the table below. Please replace the abnormal parts (if any) in time.

Vulnerable parts	Service life	Cause of damage	Criteria
Fan	30,000~40,000h	Wear of bearing and aging of blade	Check if fan blades have cracks Check if there is abnormal vibration and noise on working
Electrolytic capacitor	40,000~50,000h	Excessively high ambient temperature and excessively low air pressure result in electrolyte volatilization; aging of electrolyte capacitor	Check if there is liquid leakage Check if safety valve projects Check if capacitance value is out of allowable range Check if insulation resistance is abnormal
Relay/contact actor	50,000~100,000 times	Corrosion and dust impairs the contacting effect of contact; excessively frequent contact action	Open/close failure False alarm of CCL fault

8.4 Storage

Storage environment should meet the requirements as set forth in the table below.

Items	Requirements	Recommended storage method and environment
Storage temperature	-40~+70℃	In case of long-term storage, areas with an ambient temperature of less than 30℃ are recommended Avoid the storage in areas where temperature shock may result in condensation and freezing
Storage humidity	5~95%	Product could be sealed with plastic film and desiccant
Storage environment	A space with low vibration and low content of salt where there is no direct exposure to sunlight, dust, no corrosive or flammable gas, oil stain, vapor and water drop	Product could be sealed with plastic film and desiccant

 **ATTENTION:**

Since long-term storage may lead to the deterioration of electrolytic capacitor, the inverter must be powered up once in case storage period exceeds 2 years. After applying the power, input voltage must be boosted to rated value gradually using a voltage regulator, and be sure to have the inverter operated at no load for more than 5 hours.

Appendix Communication Protocol

1. Networking Mode

The drives have two networking modes, single master/multiple slaves networking and single master/single slave networking.

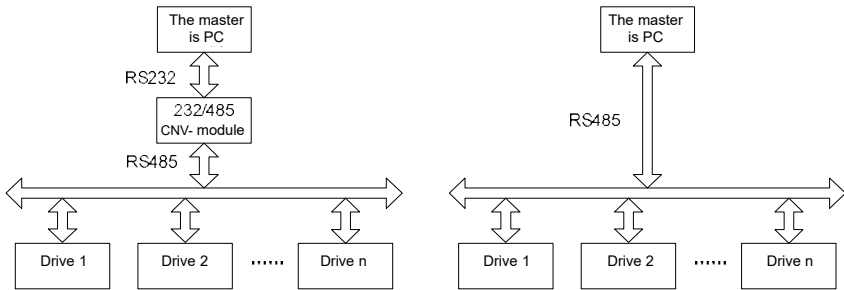

Single master/multiple slaves networking diagram

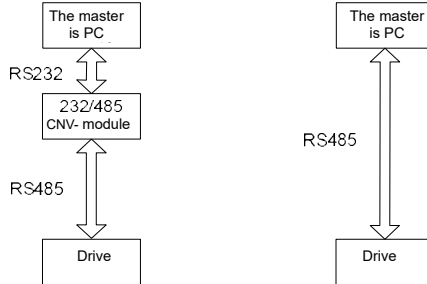

Single master/single slave networking diagram

2. Interface Mode

RS485 or RS232 interface: asynchronous, half-duplex. Default data format: 8-N-2 (8 data bits, no check, two stop bits), 9600 bps. See parameters of Group H0 for parameter setting.

3. Communication Mode

- 1) Drive is used as a slave for master-slave station-to-station communication. When master sends commands using broadcast address, the slave does not respond;

- 2) Native address, baud rate and data format of inverter are set through slave operating panel or serial communication;
- 3) Slave reports the current fault information in the latest response frame for master polling;
- 4) Drive employs RS-485 interface or extended RS-232 interface.

4. Protocol Format

Modbus protocol supports both RTU and ASCII mode.

RTU data frame format is shown as the figure below:

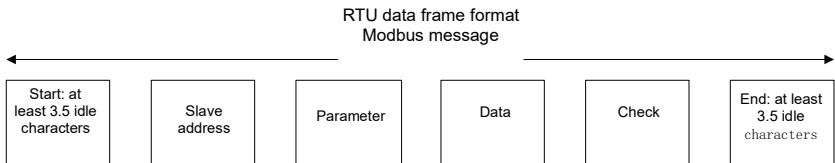

RTU:

In RTU mode, idle time between frames can be set through function code or comply with Modbus internal convention, for which the minimum interframe idle is as follows:

- 1) Frame header and end define the frame by making bus idle time equal to or longer than 3.5-byte time;
- 2) After the start of frame, the clearance between characters must be less than 1.5-character communication time, or the newly received characters will be treated as the header of the new frame;
- 3) Data check employs CRC-16 and the whole information participates in the check; the high and low bytes of check sum shall be sent after exchange. Please refer to examples at the end of protocol for details of CRC check;
- 4) The bus idle time of at least 3.5 characters (or set minimum bus idle time) shall be maintained between frames and needs not to accumulate the starting and ending idle time.

The data frame of which the request frame is "reading parameter value of b0-02 from slave 0x01" is as below:

Appendix Table 1

Address	Function code	Register address	Read words	Check sum
01	03	02 02	00 01	24 72

Response frame of slave 0x01 is as below:

Appendix Table 2

Address	Function code	Register address	Read words	Check sum
01	03	02	13 88	B5 12

ASCII:

- 1) Frame header is "0x3A" while the default frame end is "0x0D" "0x0A"; also, frame end can be configured and defined by user;
- 2) In ASCII mode, all data bytes other than frame header and end are sent in the form of ASCII code; high-4-bit byte and low-4-bit byte are sent successively;
- 3) In ASCII mode, the data is 7-bit long. For 'A'~'F', their uppercase ASCII codes are used;
- 4) Data is subjected to LRC check which covers the information portion from slave address to data;
- 5) Check sum is equal to the complement of sum of characters that participate in data check (abort the feed bit).

In ASCII mode, data frame format is as follows:

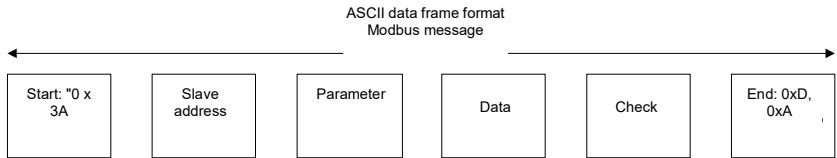

Examples of Modbus data frame in ASCII mode are as follows.

The writing of 4000 (0xFA0) into internal register 02 02 of slave 0x01 is shown in the table below.

LRC check = complement of $(01+06+02+02+0x0F+0xA0) = 0x46$

Appendix Table 3

	Header	Address		Parameter		Register address				Write-in content			LRC check		End		
Character	:	0	1	0	6	0	2	0	2	0	F	A	0	4	6	CR	LF
ASCII	3A	30	31	30	36	30	32	30	32	30	46	41	30	34	36	0D	0A

Different response delays can be set for drive through parameters so as to adapt to specific application requirements of various master stations; in RTU mode, the actual response delay is not less than 3.5 characters, while in ASCII mode, the actual response delay shall not be less than 1ms.

5. Protocol Function

The uppermost function of Modbus is to read and write parameters, and different parameters determine different operation requests. Parameters operations supported by inverter Modbus protocol are as shown in the table below:

Appendix Table 4 Parameters

Parameter	Meaning of parameter
0x03	Read drive functional parameters and run status parameters
0x06	Over-write individual drive functional parameters or control parameters, which are not saved on power loss
0x08	Line diagnosis
0x10	Over-write multiple drive functional parameters or control parameters, which are not saved on power loss
0x41	Write individual drive functional parameters or control parameters, and save them to non-volatile storage unit
0x42	Parameter management

Functional parameters, control parameters and status parameters of the drive are all mapped to read-write register of Modbus. Read-write characteristics and range of parameters comply with the instructions of user manual of the drive. Group numbers of drive parameters are mapped as high byte of register address, while in-group indexes are mapped as low byte of register address. Drive control parameters and status parameters are all virtualized as drive parameter groups. The corresponding relations between parameter group numbers and their high bytes of register address are as shown in table below:

Appendix Table 5 High-byte register addresses mapped from parameter group numbers

Parameter group	Mapping register address, high byte	Parameter group	Mapping register address, high byte
A0	0x00	E1	0x12
A1	0x01	F0	0x13
b0	0x02	F1	0x14
b1	0x03	F2	0x15
b2	0x04	F3	0x16
C0	0x05	F4	0x17
C1	0x06	F5	0x18
C2	0x07	F6	0x19

Parameter group	Mapping register address, high byte	Parameter group	Mapping register address, high byte
C3	0x08	H0	0x1A
C4	0x09	H1	0x1B
d0	0x0A	H2	0x1C
d1	0x0B	L0	0x1D
d2	0x0C	L1	0x1E
d3	0x0D	U0	0x1F
d4	0x0E	U1	0x20
d5	0x0F	U2	0x21
d6	0x10	Drive control parameter group	0x62
E0	0x11	Drive status parameter group	0x63

For example, the register address of drive parameter b0-02 is 0x0202 while that of E0-07 is 0x1107.

In the following paragraphs, we present the formats and meanings of Modbus protocol parameters and data portion hereafter, i.e. to introduce the "parameter" and "data" related contents in above-noted data frame format. These two parts constitute the application layer protocol data unit of Modbus. The application layer protocol data unit mentioned below refers to these two parts. We take RTU mode for example to describe frame format below. The length of application layer protocol data unit should be doubled in ACSII mode.

Application layer protocol data units of various parameters are as follows:

Parameter 03: read register content

Request format is shown in appendix table 6.

Appendix Table 6

Application layer protocol data unit	Data length (number of bytes)	Range
Parameter	1	0x03
Register address	2	0x0000~0xFFFF
Number of registers	12	0x0001~0x000C
Check	LRC or CRC	

Response format is shown in appendix table 7.

Appendix Table 7

Application layer protocol data unit	Data length (number of bytes)	Range
Parameter	1	0x03
Number of read bytes	1	2* number of registers
Register content	2* number of registers	
Check	LRC or CRC	

Parameter 0x06 (0x41) : write register content (0x41 saved at power loss)
 Request format is shown in appendix table 8.

Appendix Table 8

Application layer protocol data unit	Data length (number of bytes)	Range
Parameter	1	0x06
Register address	2	0x0000~0xFFFF
Register content	2	0x0000~0xFFFF
Check	LRC or CRC	

Response format is shown in appendix table 9.

Appendix Table 9

Application layer protocol data unit	Data length (number of bytes)	Range
Parameter	1	0x06
Register address	2	0x0000~0xFFFF
Register content	2	0x0000~0xFFFF
Check	LRC or CRC	

Some parameters of the drive are reserved and cannot be modified by communication setting. The list of these parameters is shown in appendix table 10.

Appendix Table 10

	Parameters	Remarks
(Parameter identification)	d0-22 d3-22	Communication not operable
(Parameter passing)	A0-05	Communication not operable
(User password)	A0-00	User password can not be set by communication, but the user password set by control panel can be unlocked by writing the same password from upper computer/device communication. Upper computer/device can view and modify parameters.

Parameter 0x08: communication line diagnosis.

Request format is shown in appendix table 11.

Appendix Table 11

Application layer protocol data unit	Data length (number of bytes)	Range
Parameter	1	0x08
Sub-parameter	2	0x0000~0x0030
Data	2	0x0000~0xFFFF
Check	LRC or CRC	

Response format is shown in appendix table 12.

Appendix Table 12

Application layer protocol data unit	Data length (number of bytes)	Range
Parameter	1	0x08
Sub-parameter	2	0x0000~0x0030
Data	2	0x0000~0xFFFF
Check	LRC or CRC	

Sub-parameters supported by line diagnosis are as set forth in the table below.

Appendix Table 13 Line diagnosis sub-parameter

Sub-PARA	Data (request)	Data (response)	Meaning of subfunction
0x0001	0x0000	0x0000	Reinitialize communication: make no-response mode disable.
	0xFF00	0xFF00	Reinitialize communication: make no-response mode disable.
0x0003	"New frame end" 00	"New frame end" 00	Set the frame end of ASCII mode and this "new frame end" will replace the original line feed symbol.(Note: new frame end shall not be greater than 0x7F and shall not be equal to 0x3A)
0x0004	0x0000	No response	Set no-response mode. Only response to reinitialization communication request. This is mainly used for isolating faulty equipment.
0x0030	0x0000	0x0000	Make slave no-response to invalid command and error command
	0x0001	0x0001	Make slave response to invalid command and error command

Parameter 0x10: write parameters continuously

Request format is shown in appendix table 14.

Appendix Table 14

Application layer protocol data unit	Data length (number of bytes)	Range
Parameter	1	0x10
Register address	2	0x0000~0xFFFF
Number of registers	2	0x0001~0x0004
Number of bytes of register content	1	2* number of operation registers
Register content	2* number of operation registers	
Check	LRC or CRC	

Response format is shown in appendix table 15.

Appendix Table 15

Application layer protocol data unit	Data length (number of bytes)	Range
Parameter	1	0x10
Register address	2	0x0000~0xFFFF
Number of registers	2	0x0001~0x0004
Check	LRC or CRC	

Parameter 0x42: parameter management

Request format is shown in appendix table 16.

Appendix Table 16

Application layer protocol data unit	Data length (number of bytes)	Range
Parameter	1	0x42
Sub-parameter	2	0x0000~0x0007
Data	2 (high byte is parameter group number, while low byte is parameter in-group index)	
Check	LRC or CRC	

Response format is shown in appendix table 17.

Appendix Table 17

Application layer protocol data unit	Data length (number of bytes)	Range
Parameter	1	0x42
Sub-parameter	2	0x0000~0x0007
Data	2	0x0000~0xFFFF
Check	LRC or CRC	

Sub-parameters supported by parameter management are set forth in the table 18.

Appendix Table 18 Parameter management sub-parameters

Sub-PARA	Data (request)	Data (response)	Meaning of subfunction
0x0000	Parameter group number and in-group index respectively possess high and low bytes	Upper limit of parameter	Read the upper limit of parameter
0x0001	Parameter group number and in-group index respectively possess high and low bytes	Lower limit of parameter	Read the lower limit of parameter
0x0002	Parameter group number and in-group index respectively possess high and low bytes	See specification below for details of parameter characteristics	Read the characteristics of parameter
0x0003	Parameter group number possesses high byte, while the lower byte is 0.	Maximum value of in-group index	Read the maximum value of in-group index
0x0004	Parameter group number possesses high byte, while the lower byte is 0.	The next parameter group number possesses high byte, while the lower byte is 0.	Read the next parameter group number
0x0005	Parameter group number possesses high byte, while the lower byte is 0.	The previous parameter group number possesses high byte, while the lower byte is 0.	Read the previous parameter group number

Status parameter group should not be modified and does not support the reading of upper and lower limits. Parameter characteristic is 2-byte long, and the bit definition is shown in the table below:

Appendix Table 19 Parameter characteristics

Characteristic parameter (BIT)	Value	Meaning
BIT1~BIT0	00B	Changeable in run
	01B	Not changeable in run, but changeable in stop
	10B	Read only
	11B	Factory parameters

Characteristic parameter (BIT)	Value	Meaning
BIT4~BIT2	000B	Accuracy: 1
	001B	Accuracy: 0.1
	010B	Accuracy: 0.01
	011B	Accuracy: 0.001
	100B	Accuracy: 0.0001
	Others	Reserved
BIT7~BIT5	000B	The unit is A
	001B	The unit is Hz
	010B	The unit is Ω
	011B	The unit is r/min
	100B	The unit is S
	101B	The unit is V
	110B	The unit is %
	111B	No unit
BIT8	0: decimal; 1: hexadecimal	Display format
BIT9	0: non-quick menu; 1: quick menu	Quick menu or not
BIT10	0: not uploaded; 1: uploaded	Uploaded to control panel or not
BIT13~BIT11	001B	Data width: 1
	010B	Data width: 2
	011B	Data width: 3
	100B	Data width: 4
	101B	Data width: 5
	110B	Data width: 6
	111B	Data width: 7
BIT14	Number of symbols available/not available	0: unsigned number; 1: directed number
BIT15	Reserved	Reserved

The response format is shown as table 20 when an error occurs.

Appendix Table 20

Application layer protocol data unit	Data length (number of bytes)	Range
Parameter	1	0x80 + parameter
Error code	1	
Check	LRC or CRC	

Error codes supported by Modbus protocol are listed in the table below:

Appendix Table 21 Error codes

Error codes	Meanings of error codes
0x01	Illegal parameter
0x02	Illegal register address
0x03	Data error, i.e. data are out of upper limit or lower limit
0x04	Slave operation failed, including errors caused by invalid data although there are in the range
0x05	Command is valid and being processed, mainly used for storing data to non-volatile storage
0x06	Slave is busy, please try again later; mainly used for storing data into non-volatile storage
0x18	Message frame error: including message length error and check error
0x20	Parameter is not changeable
0x21	Parameter is not changeable during the running
0x22	Parameter is under password protection

Drive control parameters are used for start, stop and run frequency setting. By detecting drive status parameters, run status and run mode can be obtained. Drive control parameters and status parameters are shown in appendix table 22.

Appendix Table 22 Control parameters

Register address	Parameter name	Save at power loss
0x6200	Control command word	No
0x6201	Master frequency setting	Yes
0x6202	Auxiliary frequency setting	Yes
0x6203	Master frequency setting	No
0x6204	Auxiliary frequency setting	No

Register address	Parameter name	Save at power loss
0x6205	Multi-step frequency setting	No
0x6206	Simple PLC frequency setting	No
0x6207	PID digital setting percentage (0~100.0%)	No
0x6208	PID feedback percentage (0~100.0%)	No
0x6209	Electric driven torque limit (0~200.0%)	No
0x620A	Brake torque limit (0~200.0%)	No
0x620B	Reserved	No
0x620C	Reserved	No
0x620D	Reserved	No
0x620E	Analog AO1 source setting	No
0x620F	Analog EAO source setting	No
0x6210	Digital DO output source setting	No
0x6211	Setting of slave frequency setting proportion (0~100.0%)	No
0x6212	Virtual terminal communication setting	No
0x6213	Accel time 1	Yes
0x6214	Decel time 1	Yes

Appendix Table 23 Status parameters

Register address	Parameter name
0x6300	Run status word 1
0x6301	Current run frequency
0x6302	Output current
0x6303	Output voltage
0x6304	Output power
0x6305	Rotary speed
0x6306	Bus voltage
0x6307	Output torque
0x6308	External counter
0x6309	High-bit words of actual length

Register address	Parameter name
0x630A	Low-bit words of actual length
0x630B	Status of digital input terminal
0x630C	Status of digital output terminal
0x630D	Setting of run frequency
0x630E	PID setting
0x630F	PID feedback
0x6310	Set length
0x6311	Set Accel time 1
0x6312	Set Decel time 1
0x6313	AI1 (unit: V)
0x6314	AI2 (unit: V) (Negative value indicates the corresponding digital complement)
0x6315	EAI (unit: V)
0x6316	DI (unit: kHz)
0x6317	Fault 1
0x6318	Fault 2
0x6319	Fault 3 (the latest)
0x631A	Run display parameter
0x631B	Stop display parameter
0x631C	Setting of drive control mode
0x631D	Frequency setting mode
0x631E	Master frequency setting
0x631F	Digital setting of master frequency
0x6320	Auxiliary frequency setting
0x6321	Digital setting of auxiliary frequency
0x6322	Drive status word 2
0x6323	Current fault of the drive

Drive control bits are defined as below table 24.

Appendix Table 24 Control bits

Control bit	Value	Meaning	Function description
BIT0	0	Run command disabled	Stop the drive

Control bit	Value	Meaning	Function description
	1	Run command enabled	Start the drive
BIT1	1	Reverse	Set the run direction when run command enabled
	0	Forward	
BIT2	1	Jog	
	0	Jog disabled	
BIT3	1	Reset command enabled	
	0	Reset command disabled	
BIT4	1	Coast to stop enabled	
	0	Coast to stop disabled	
BIT15~BIT5	000000B	Reserved	

 **ATTENTION:**

When BIT0 and BIT2 coexist, jog takes precedence.

Drive status bits are shown in appendix table 25.

Appendix Table 25 Status word 1 bits

Status bit	Value	Meaning	Remarks
BIT0	1	Run	
	0	Stop	
BIT1	1	Reverse	
	0	Forward	
BIT3~BIT2	00B	Constant speed	
	01B	Accel	
	10B	Decel	
BIT4	0	Main setting not attained	
	1	Main setting attained	
BIT7~BIT5	Reserved		
BIT15~BIT8	0x00~0xFF	Fault code	0: drive normal. Non-0: drive at fault; Refer to relative specification of the fault codes in Chapter 7 in this user manual

Appendix Table 26 Status word 2 bits

Status bit	Value	Meaning	Remarks
BIT0	1	Jog	
	0	Non-jog	
BIT1	1	PID run	
	0	Non-PID run	
BIT2	1	PLC run	
	0	Non-PLC run	
BIT3	1	Run at multi-step frequency	
	0	Run at non-multi step frequency	
BIT4	1	Ordinary run	
	0	Non-ordinary run	
BIT5	1	Wobble frequency	
	0	Non-wobble frequency	
BIT6	1	Undervoltage	
	0	Normal voltage	
BIT7	1	Sensor-less vector control	
	0	Non-sensor-less vector control	
BIT8	0	Reserved	
BIT9	0	Reserved	
BIT10	1	Autotuning	
	0	Non-autotuning	
Others	0	Reserved	

6. Operation Instructions

0x03 reads multiple (including one) registers (default address is 0x01). Master enquiry:

Appendix Table 27

Address	Parameter	Register address	Number of registers	Check code
01	03	XX XX	000X	XX XX

Slave response:

Appendix Table 28

Address	Parameter	Total number of bytes	Data	Check code
01	03	2* number of registers	Bn~B0	XX XX

Register address: 0x00 00~0x63 22;

Number of registers: 0x00 01~0x00 0C;

Data: n is equal to (2 x the number of registers -1).

Application example:

Note: before using communication controlling drive, please check if hardware is properly connected; in addition, be sure to properly set the communication data format, baud rate and address.

Parameter 0x03 is used here to read values of 0x01 slave's control parameters b0-00, b0-01, b0-02 and b0-03. At this moment, b0-00 = 0, b0-01 = 0, b0-02 = 50.00, b0-03 = 0.

Appendix Table 29

	Address	PARAM	Register address	Number of registers	Number of data bytes	Data	Check sum
Request	01	03	02 00	00 04	None	None	44 B1
Response	01	03	None	None	08	0000,0000, 1388, 0000	11 79

Management of parameter 42H

Master enquiry:

Appendix Table 30

Address	Parameter	Sub-parameter	Data	Check code
01	42	XX XX	XX XX	XX XX

Slave response:

Appendix Table 31

Address	Parameter	Sub-parameter	Data	Check code
01	42	XX XX	B1~B0	XX XX

Register address: 0x00 00~0x21 06 and 0x62 00~0x63 22.

Sub-parameter: refer to the table of parameter managing sub-parameter.

Data: refer to the values of data as set forth in the table of parameter managing sub-parameter.

Example:

Parameter 0x42 is used here to read the upper limit value of 0x01 slave's control parameter b0-02 which is 600.00:

Appendix Table 32

	Address	Parameter	Sub-PARA	Data	Check sum
Request	01	42	00 00	02 02	F9 64
Response	01	42	00 00	EA 60	36 8D

0x06 (0x41 data storage) writes that individual parameter data is not saved.

Master enquiry:

Appendix Table 33

Address	Parameter	Register address	Data	Check code
01	06	62 00	B1 B0	XX XX

Slave response:

Appendix Table 34

Address	Parameter	Register address	Data	Check code
01	06	62 00	B1 B0	XX XX

Example:

Parameter 0x06 is used here to write 0x01 slave's control command (forward), i.e. to write 1 to register address 0x6200:

Appendix Table 35

	Address	Parameter	Register address	Number of registers	Number of data bytes	Data	Check sum
--	---------	-----------	------------------	---------------------	----------------------	------	-----------

Request	01	06	62 00	None	None	00 01	57 B2
Response	01	06	62 00	None	None	00 01	57 B2

10H writes that the data of multiple registers are not saved.

Master enquiry:

Appendix Table 36

Address	Parameter	Register address	Number of registers	Number of data bytes	Data	Check code
01	10	XX XX	0001~0004	Number of 2* registers	XX XX	XX XX

Slave response:

Appendix Table 37

Address	Parameter	Register address	Number of registers	Check code
01	10	XX XX	Number of 2* registers	XX XX

Register address: 0x00 00~0x1E 04, 0x62 00~0x62 14

Number of registers: 0x00 01~0x00 04

Number of data bytes: 0x02~0x08

Data: n is equal to (2 x the number of registers -1).

Example:

Parameter 0x10 is used here to write the corresponding write data 1, 6 and 0 in control registers 0x6200, 0x6201 and 0x6202 of slave 0x01:

Appendix Table 38

	Address	Parameter	Register address	Number of registers	Number of data bytes	Data	Check sum
Request	01	10	62 00	00 03	06	0001,0006,0000	CE F8
Response	01	10	62 00	00 03	None	None	9F B0

08H: communication line diagnosis

Master enquiry:

Appendix Table 39

Address	Parameter	Sub-parameter	Data	Check code
01	08	XX XX	XX XX	XX XX

Slave response:

Appendix Table 40

Address	Function code	Subfunction code	Data	Check code
01	08	XX XX	Bn~B0	XX XX

Sub-parameter: table of line diagnosis sub-parameter.

Example:

Parameter 0x08 is used here to set the communication no-response mode of 0x01 slave:

Appendix Table 41

	Address	Parameter	Sub-PARA	Data	Check sum
Request	01	08	00 04	00 00	A1 CA
Response	01	08	00 04	00 00	A1 CA

Read error or warning

In case illegal parameter, illegal register address, data errors and other anomalies are detected during communication, slave response communication anomaly will occur. In such a case, the slave response will be in the following formats:

Slave response:

Appendix Table 42

Address	Parameter	Data	Check code
01	0x80+parameter	Error code	XX XX

Example:

Parameter 0x10 is used here to write the corresponding write data 1, 11, 4 and 100.00 in control registers 0x6200, 0x6201, 0x6202 and 0x6203 of 0x01 slave:

Appendix Table 43

	Address	Parameter	Register address	Number of registers	Number of data bytes	Data	Check sum
Request	01	10	62 00	00 04	08	0001,000B 0004 2710	DE 64
Response	01	90	None	None	None	20	0C 01

7. LRC/CRC Generation

In consideration of the demand for speed improvement, CRC-16 is usually realized in form mode. C-language source codes for realization of CRC-16 are given below. Please note that the high and low bytes have been exchanged in final result, that is to say, the result is the CRC check sum to be sent:

```
/* The function of CRC16*/
Uint16 CRC16(const Uint16 *data, Uint16 len)
{
    Uint16 crcValue = 0xffff;
    Uint16 i;
    while (len-->0)
    {
        crcValue ^= *data++;
        for (i = 0; i <= 7; i++)
        {
            if (crcValue & 0x0001)
            {
                crcValue = (crcValue >> 1) ^ 0xa001;
            }
            else
            {
                crcValue = crcValue >> 1;
            }
        }
    }
    return (crcValue);
}
```