

• 15P0078B1 •

ASAB

ADVANCED SOFT STARTER

INSTALLATION AND PROGRAMMING INSTRUCTIONS

Issued on 22/05/13
R. 03

English

- This manual is integrant and essential to the product. Carefully read the instructions contained herein as they provide important hints for use and maintenance safety.
- This device is to be used only for the purposes it has been designed to. Other uses should be considered improper and dangerous. The manufacturer is not responsible for possible damages caused by improper, erroneous and irrational uses.
- Elettronica Santerno is responsible for the device in its original setting.
- Any changes to the structure or operating cycle of the device must be performed or authorized by the Engineering Department of Elettronica Santerno.
- Elettronica Santerno assumes no responsibility for the consequences resulting from the use of non-original spare parts.
- Elettronica Santerno reserves the right to make any technical changes to this manual and to the device without prior notice. If printing errors or similar are detected, corrections will be included in new releases of the manual.
- The information contained herein is the property of Elettronica Santerno and cannot be reproduced. Elettronica Santerno enforces its rights on the drawings and catalogues according to the law.



Elettronica Santerno S.p.A.
S.S. Selice, 47 – 40026 Imola (BO) Italy
Tel. +39 0542 489711 – Fax +39 0542 489722
www.santerno.com sales@santerno.com

Contents

1	About This Manual	3
2	Caution Statements	3
2.1	Electrical Shock Risk	3
2.2	System Design and Safety of Personnel	3
2.3	Disposal Instructions	4
3	Introduction	5
3.1	Feature List	5
3.2	Specifications	5
4	Installation	11
4.1	Physical Installation	11
4.2	Control Terminals	11
4.3	Control Voltage	12
4.4	Control Wiring	12
4.5	Relay Outputs	12
4.6	Motor Thermistors	12
4.7	Power Terminations	13
4.8	Power Input and Output Configurations	14
4.9	Schematic Diagrams	15
5	Power Circuits	16
5.1	Motor Connection	16
5.2	Bypass Contactor	19
5.3	Main Contactor	19
5.4	Circuit Breaker	19
5.5	Earth Terminals	19
5.6	Power Factor Correction	19
5.7	Power Supply Fuses	19
6	Operation	24
6.1	Keypad and Feedback	24
6.2	Start, Stop and Reset Commands	26
6.3	Soft Start Methods	26
6.4	Stop Methods	29
6.5	Jog Operation	31
6.6	Inside Delta Operation	32
7	Programming Menu	33
7.1	Quick Setup	34
7.2	Standard Menu	35
7.3	Extended Menu	36
7.4	Parameter Descriptions	38
7.5	Adjustment Lock	49
7.6	Access Code	49
7.7	Setup Tools	49
8	Logs Menu	51
8.1	Trip Log	51
8.2	Event Log	51
8.3	Performance Counters	51
9	Application Examples	52
9.1	Installation with Main Contactor	52
9.2	Installation with Bypass Contactor	53
9.3	Emergency Run Operation	54
9.4	Auxiliary Trip Circuit	55
9.5	DC Brake with External Zero Speed Sensor	56
9.6	Soft Braking	57
9.7	Two Speed Motor	58
10	Troubleshooting	59

10.1	Protection Responses	59
10.2	Trip Messages	59
10.3	General Faults	62
11	Accessories	64
11.1	Communication Modules	64
11.2	Remote Control Panel (RCP)	64
11.3	Finger Guard Kit	64
11.4	PC Software	64
12	Busbar Adjustment Procedure	65

1 About This Manual

The examples and diagrams in this manual are included solely for illustrative purposes. The information contained in this manual is subject to change at any time and without prior notice. In no event will responsibility or liability be accepted for direct, indirect or consequential damages resulting from the use or application of this equipment.



WARNING

Indicates a hazard that may cause personal injury or death.



CAUTION

Indicates a hazard that may damage the equipment or installation.



NOTE

Provides helpful information.

2 Caution Statements



This symbol is used throughout this manual to draw attention to topics of special importance to the installation and operation of equipment.

Caution Statements cannot cover every potential cause of equipment damage but can highlight common causes of damage. It is the installer's responsibility to read and understand all instructions in this manual prior to installing, operating or maintaining the equipment, to follow good electrical practice including applying appropriate personal protective equipment and to seek advice before operating this equipment in a manner other than as described in this manual.



NOTE

The ASAB soft starter is not user serviceable. The unit should only be serviced by authorised service personnel. Unauthorised tampering with the unit will void the product warranty.

2.1 Electrical Shock Risk

The voltages present in the following locations can cause severe electric shock and may be lethal:

- AC supply cables and connections
- Output cables and connections
- Many internal parts of the starter, and external option units

The AC supply must be disconnected from the starter using an approved isolation device before any cover is removed from the starter or before any servicing work is performed.



WARNING - ELECTRICAL SHOCK HAZARD

Models ASAB-0500B~ASAB-1600C: The busbar and heatsink must be treated as live whenever the unit has mains voltage connected (including when the starter is tripped or waiting for a command).



SHORT CIRCUIT

The ASAB is not short circuit proof. After severe overload or short circuit, the operation of the ASAB should be fully tested by an authorised service agent.



GROUNDING AND BRANCH CIRCUIT PROTECTION

It is the responsibility of the user or person installing the ASAB to provide proper grounding and branch circuit protection according to local electrical safety codes.

2.2 System Design and Safety of Personnel

The starter is intended as a component for professional incorporation into complete equipment or a system. If installed incorrectly, the starter may present a safety hazard.

The starter uses high voltages and currents, carries stored electrical energy, and is used to control equipment which can cause injury.

Close attention is required to the electrical installation and the system design to avoid hazards either in normal operation or in the event of equipment malfunction. System design, installation, commissioning and maintenance must be carried out by personnel who have the necessary training and experience. They must read this safety information and this guide carefully.

None of the starter functions must be used to ensure safety of personnel, ie they must not be used for safety-related functions.

Careful consideration must be given to the functions of the starter which might result in a hazard, either through their intended behaviour or through incorrect operation due to a fault. In any application where a malfunction of the starter or its control system could lead to or allow damage, loss or injury, a risk analysis must be carried out, and where necessary, further measures taken to reduce the risk.

The system designer is responsible for ensuring that the complete system is safe and designed correctly according to the relevant safety standards.

2.2.1 STOP function

The STOP function does not remove dangerous voltages from the starter, the motor or any external option units.

2.3 Disposal Instructions



Equipment containing electrical components may not be disposed of together with domestic waste.

It must be collected separately as electrical and electronic waste according to local and currently valid legislation.

3 Introduction

The ASAB is an advanced digital soft start solution for motors from 11 kW to 850 kW. ASAB soft starters provide a complete range of motor and system protection features and have been designed for reliable performance in the most demanding installation situations.

3.1 Feature List

Extensive starting and stopping options

- Adaptive control
- Constant current
- Current ramp
- Timed voltage ramp soft stop
- Brake

Models for all connection requirements

- 23 A to 1600 A (nominal)
- 200 VAC to 525 VAC
- 380 VAC to 690 VAC
- Internally bypassed options
- In-line or inside delta connection (auto-detect)

Inputs and outputs

- Remote control inputs (3 x fixed, 1 x programmable)
- Relay outputs (3 x programmable)
- Analog output
- DeviceNet, Modbus, Profibus, Ethernet (Ethernet IP, Modbus TCP, Profinet) or USB communication modules (optional)

Easy-to-read display with comprehensive feedback

- Multi-language feedback
- Multiple status screens and performance graphs
- Date and time stamped event logging
- Operational counters (number of starts, hours run, kWh)
- Performance monitoring (current, voltage, power factor, kWh)
- User-programmable monitoring screen

Customisable protection

- Motor overload
- Excess start time
- Undercurrent
- Instantaneous overcurrent
- Current imbalance
- Mains frequency
- Input trip
- Motor thermistor
- Power circuit
- Phase sequence

3.2 Specifications

3.2.1 Model Code

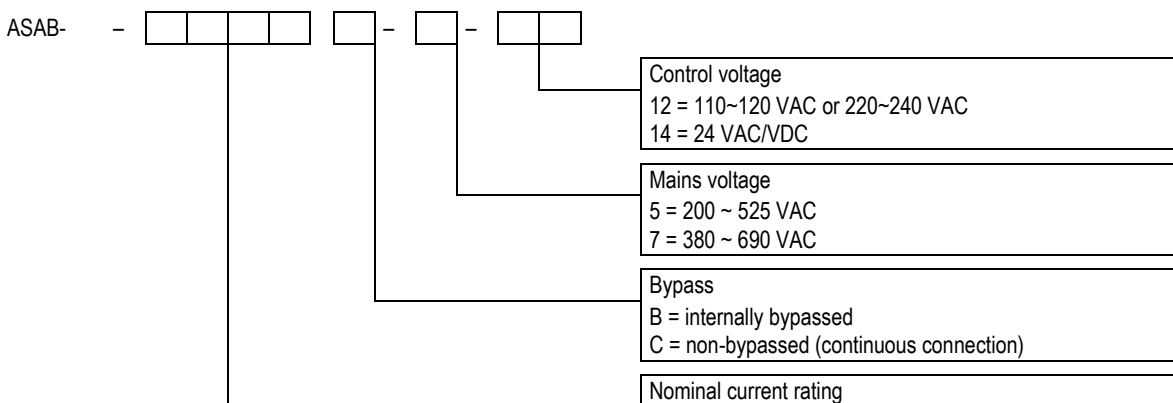

3.2.2 Current Ratings

Contact your local supplier for ratings under operating conditions not covered by these ratings charts.

Current Ratings for Bypass Operation

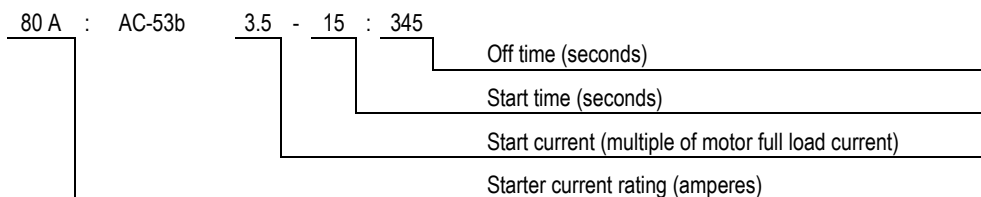

NOTE

Models ASAB-0255C~ASAB-1600C must be externally bypassed.

In-line connection

	AC53b 3.0-10:350 40 °C <1000 metres	AC53b 3.5-15:345 40 °C <1000 metres	AC53b 4.0-20:340 40 °C <1000 metres	AC53b 4.5-30:330 40 °C <1000 metres
ASAB-0023B	23 A	20 A	17 A	15 A
ASAB-0043B	43 A	37 A	31 A	26 A
ASAB-0053B	53 A	53 A	46 A	37 A
	AC53b 3.0-10:590 40 °C <1000 metres	AC53b 3.5-15:585 40 °C <1000 metres	AC53b 4.0-20:580 40 °C <1000 metres	AC53b 4.5-30:570 40 °C <1000 metres
ASAB-0076B	76 A	64 A	55 A	47 A
ASAB-0097B	97 A	82 A	69 A	58 A
ASAB-0100B	100 A	88 A	74 A	61 A
ASAB-0105B	105 A	105 A	95 A	78 A
ASAB-0145B	145 A	123 A	106 A	90 A
ASAB-0170B	170 A	145 A	121 A	97 A
ASAB-0200B	200 A	189 A	160 A	134 A
ASAB-0220B	220 A	210 A	178 A	148 A
ASAB-0255B	255 A	231 A	201 A	176 A
ASAB-0255C	255 A	231 A	201 A	176 A
ASAB-0350B	350 A	329 A	284 A	244 A
ASAB-0380C	380 A	380 A	359 A	299 A
ASAB-0425B	425 A	411 A	355 A	305 A
ASAB-0430C	430 A	430 A	368 A	309 A
ASAB-0500B	500 A	445 A	383 A	326 A
ASAB-0580B	580 A	492 A	425 A	364 A
ASAB-0620C	620 A	620 A	540 A	434 A
ASAB-0650C	650 A	650 A	561 A	455 A
ASAB-0700B	700 A	592 A	512 A	438 A
ASAB-0790C	790 A	790 A	714 A	579 A
ASAB-0820B	820 A	705 A	606 A	516 A
ASAB-0920B	920 A	804 A	684 A	571 A
ASAB-0930C	930 A	930 A	829 A	661 A
ASAB-1000B	1000 A	936 A	796 A	664 A
ASAB-1200C	1200 A	1200 A	1200 A	1071 A
ASAB-1410C	1410 A	1410 A	1319 A	1114 A
ASAB-1600C	1600 A	1600 A	1600 A	1353 A

Inside delta connection

	AC53b 3.0-10:350 40 °C <1000 metres	AC53b 3.5-15:345 40 °C <1000 metres	AC53b 4.0-20:340 40 °C <1000 40 °C <1000 metres	AC53b 4.5-30:330 40 °C <1000 metres
ASAB-0023B	34 A	30 A	26 A	22 A
ASAB-0043B	64 A	59 A	51 A	44 A
ASAB-0053B	79 A	79 A	69 A	55 A
	AC53b 3.0-10:590 40 °C <1000 metres	AC53b 3.5-15:585 40 °C <1000 metres	AC53b 4.0-20:580 40 °C <1000 metres	AC53b 4.5-30:570 40 °C <1000 metres
ASAB-0076B	114 A	96 A	83 A	70 A
ASAB-0097B	145 A	123 A	104 A	87 A
ASAB-0100B	150 A	132 A	112 A	92 A
ASAB-0105B	157 A	157 A	143 A	117 A
ASAB-0145B	218 A	184 A	159 A	136 A
ASAB-0170B	255 A	217 A	181 A	146 A
ASAB-0200B	300 A	283 A	241 A	200 A
ASAB-0220B	330 A	315 A	268 A	223 A
ASAB-0255B	382 A	346 A	302 A	264 A
ASAB-0255C	382 A	346 A	302 A	264 A
ASAB-0350B	525 A	494 A	427 A	366 A
ASAB-0380C	570 A	570 A	539 A	449 A
ASAB-0425B	638 A	617 A	533 A	458 A
ASAB-0430C	645 A	645 A	552 A	464 A
ASAB-0500B	750 A	668 A	575 A	490 A

ASAB-0580B	870 A	738 A	637 A	546 A
ASAB-0620C	930 A	930 A	810 A	651 A
ASAB-0650C	975 A	975 A	842 A	683 A
ASAB-0700B	1050 A	889 A	768 A	658 A
ASAB-0790C	1185 A	1185 A	1071 A	868 A
ASAB-0820B	1230 A	1058 A	910 A	774 A
ASAB-0920B	1380 A	1206 A	1026 A	857 A
ASAB-0930C	1395 A	1395 A	1244 A	992 A
ASAB-1000B	1500 A	1404 A	1194 A	997 A
ASAB-1200C	1800 A	1800 A	1800 A	1606 A
ASAB-1410C	2115 A	2115 A	1979 A	1671 A
ASAB-1600C	2400 A	2400 A	2400 A	2030 A

Current Ratings for Continuous Operation (Not bypassed)

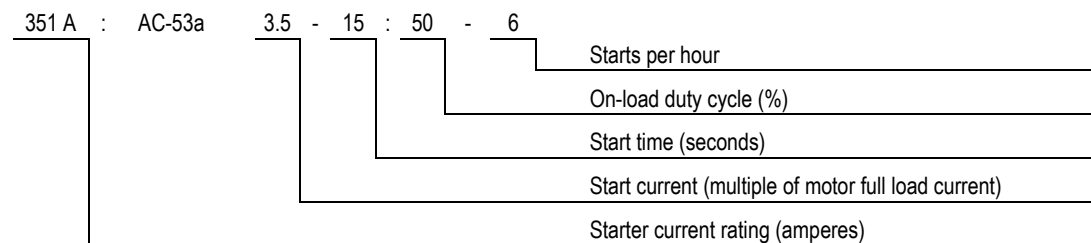

In-line connection

	AC53a 3-10:50-6 40 °C <1000 metres	AC53a 3.5-15:50-6 40 °C <1000 metres	AC53a 4-20:50-6 40 °C <1000 metres	AC53a 4.5-30:50-6 40 °C <1000 metres
ASAB-0255C	255 A	222 A	195 A	171 A
ASAB-0380C	380 A	380 A	348 A	292 A
ASAB-0430C	430 A	413 A	355 A	301 A
ASAB-0620C	620 A	614 A	515 A	419 A
ASAB-0650C	650 A	629 A	532 A	437 A
ASAB-0790C	790 A	790 A	694 A	567 A
ASAB-0930C	930 A	930 A	800 A	644 A
ASAB-1200C	1200 A	1200 A	1135 A	983 A
ASAB-1410C	1410 A	1355 A	1187 A	1023 A
ASAB-1600C	1600 A	1600 A	1433 A	1227 A

Inside delta connection

	AC53a 3-10:50-6 40 °C <1000 metres	AC53a 3.5-15:50-6 40 °C <1000 metres	AC53a 4-20:50-6 40 °C <1000 metres	AC53a 4.5-30:50-6 40 °C <1000 metres
ASAB-0255C	382 A	334 A	293 A	257 A
ASAB-0380C	570 A	570 A	522 A	437 A
ASAB-0430C	645 A	620 A	533 A	451 A
ASAB-0620C	930 A	920 A	773 A	628 A
ASAB-0650C	975 A	943 A	798 A	656 A
ASAB-0790C	1185 A	1185 A	1041 A	850 A
ASAB-0930C	1395 A	1395 A	1200 A	966 A
ASAB-1200C	1800 A	1800 A	1702 A	1474 A
ASAB-1410C	2115 A	2033 A	1780 A	1535 A
ASAB-1600C	2400 A	2400 A	2149 A	1840 A

Minimum and Maximum Current Settings

The ASAB's minimum and maximum full load current settings depend on the model:

Model	In-line connection		Inside delta connection	
	Minimum	Maximum	Minimum	Maximum
ASAB-0023B	5 A	23 A	5 A	34 A
ASAB-0043B	9 A	43 A	9 A	64 A
ASAB-0053B	11 A	53 A	11 A	79 A
ASAB-0076B	15 A	76 A	15 A	114 A
ASAB-0097B	19 A	97 A	19 A	145 A
ASAB-0100B	20 A	100 A	20 A	150 A
ASAB-0105B	21 A	105 A	21 A	157 A
ASAB-0145B	29 A	145 A	29 A	217 A
ASAB-0170B	34 A	170 A	34 A	255 A
ASAB-0200B	40 A	200 A	40 A	300 A
ASAB-0220B	44 A	220 A	44 A	330 A
ASAB-0255B	51 A	255 A	51 A	382 A
ASAB-0255C	51 A	255 A	51 A	382 A
ASAB-0350B	70 A	350 A	70 A	525 A
ASAB-0380C	76 A	380 A	76 A	570 A
ASAB-0425B	85 A	425 A	85 A	638 A
ASAB-0430C	86 A	430 A	86 A	645 A
ASAB-0500B	100 A	500 A	100 A	750 A
ASAB-0580B	116 A	580 A	116 A	870 A
ASAB-0620C	124 A	620 A	124 A	930 A
ASAB-0650C	130 A	650 A	130 A	975 A
ASAB-0700B	140 A	700 A	140 A	1050 A
ASAB-0790C	158 A	790 A	158 A	1185 A
ASAB-0820B	164 A	820 A	164 A	1230 A
ASAB-0920B	184 A	920 A	184 A	1380 A
ASAB-0930C	186 A	930 A	186 A	1395 A
ASAB-1000B	200 A	1000 A	200 A	1500 A
ASAB-1200C	240 A	1200 A	240 A	1800 A
ASAB-1410C	282 A	1410 A	282 A	2115 A
ASAB-1600C	320 A	1600 A	320 A	2400 A

3.2.3 Dimensions and Weights

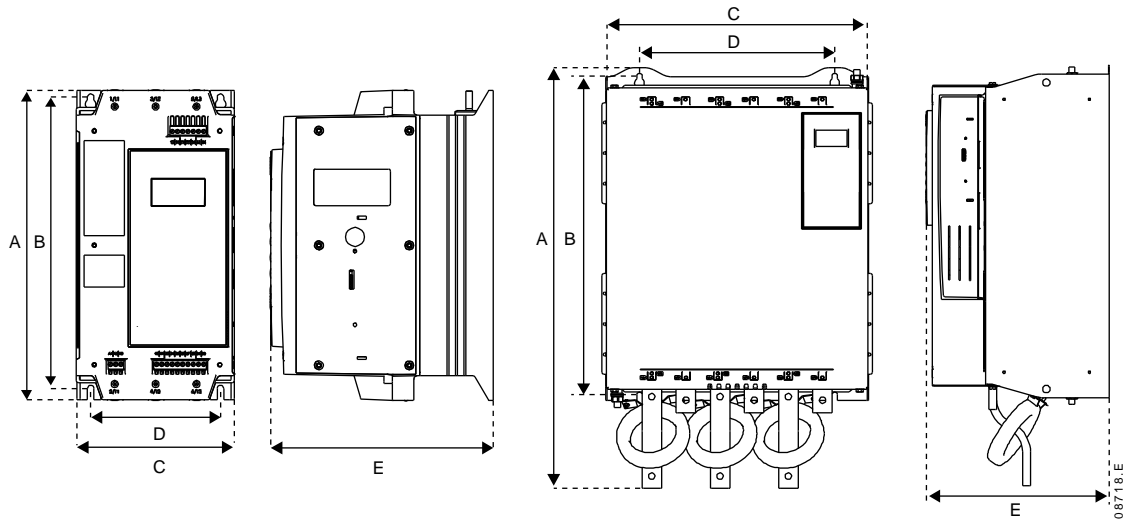

Model	A mm (inch)	B mm (inch)	C mm (inch)	D mm (inch)	E mm (inch)	Weight kg (lb)
ASAB-0023B	295 (11.6)	278 (10.9)	150 (5.9)	124 (4.9)	183	4.3
ASAB-0043B					(7.2)	(9.5)
ASAB-0053B					213 (8.4)	4.5 (9.9)
ASAB-0076B						
ASAB-0097B						
ASAB-0100B					250 (9.8)	15
ASAB-0105B						
ASAB-0145B						
ASAB-0170B	440 (17.3)	392 (15.4)	424 (16.7)	376 (14.8)	250	26 (57.2)
ASAB-0200B					(9.8)	30.2
ASAB-0220B					(11.7)	(66.58)
ASAB-0255B	640 (25.2)	600 (23.6)	433 (17.0)	320 (12.6)	295 (11.6)	49.5
ASAB-0500B						(109.13)
ASAB-0580B						60.0 (132.3)
ASAB-0700B						
ASAB-0820B						
ASAB-0920B						
ASAB-1000B						460 (18.1)
ASAB-0255C						
ASAB-0380C						
ASAB-0430C	689 (27.1)	522 (20.6)	430 (16.9)	320 (12.6)	300 (11.8)	45.0
ASAB-0620C						(98.1)
ASAB-0650C						53.0 (116.8)
ASAB-0790C						
ASAB-0930C						
ASAB-1200C	856 (33.7)	727 (28.6)	585 (23.0)	500 (19.7)	364 (14.3)	117
ASAB-1410C						(257.9)
ASAB-1600C						130 (286.6)

3.2.4 Specifications

Supply

Mains voltage (L1, L2, L3)

5	200 VAC ~ 525 VAC (± 10%)
7	380 VAC ~ 600 VAC (± 10%) (in-line or inside delta connection)
7	380 VAC ~ 690 VAC (± 10%) (earthed star supply system only)

Control voltage (A4, A5, A6)

12	110 ~ 120 VAC or 220 ~ 240 VAC (+ 10% / -15%), 600mA
14	24 VAC/VDC ±20%, 2.8A

Mains frequency 45 Hz ~ 66 Hz
 Rated insulation voltage to earth 600 VAC
 Rated impulse withstand voltage 4 kV
 Form designation Bypassed or continuous, semiconductor motor starter form 1

Short circuit capability

Coordination with semiconductor fuses Type 2
 Coordination with HRC fuses Type 1
 ASAB-0023B ~ ASAB-0220B prospective current 65 kA
 ASAB-0255B ~ ASAB-1000B prospective current 85 kA
 ASAB-0255C ~ ASAB-0930C prospective current 85 kA
 ASAB-1200C ~ ASAB-1600C prospective current 100 kA

Electromagnetic capability (compliant with EU Directive 89/336/EEC)

EMC Emissions IEC 60947-4-2 Class B and Lloyds Marine No 1 Specification
 EMC Immunity IEC 60947-4-2

Inputs

Input rating Active 24 VDC, 8 mA approx
 Start (54, 55) Normally Open
 Stop (56, 57) Normally Closed
 Reset (58, 57) Normally Closed
 Programmable input (53, 55) Normally Open
 Motor thermistor (64, 65) Trip >3.6 kΩ, reset <1.6kΩ

Outputs

Relay outputs 10A @ 250 VAC resistive, 5A @ 250 VAC AC15 pf 0.3
 Programmable outputs
 Relay A (13, 14) Normally Open
 Relay B (21, 22, 24) Changeover
 Relay C (33, 34) Normally Open
 Analog output (40, 41) 0-20 mA or 4-20 mA (selectable)
 Maximum load 600 Ω (12 VDC @ 20 mA)
 Accuracy ± 5%
 24 VDC output (55, 41)
 Maximum load 200 mA
 Accuracy ± 10%

Environmental

Protection
 ASAB-0023B ~ ASAB-0105B IP20
 ASAB-0145B ~ ASAB-1600C IP00
 Operating temperature -10 °C to 60 °C, above 40 °C with derating
 Storage temperature -25 °C to + 60 °C
 Operating Altitude 0 - 1000 m, above 1000 m with derating
 Humidity 5% to 95% Relative Humidity
 Pollution degree Pollution Degree 3
 Vibration (ASAB-0023B ~ ASAB-1000B) IEC 60068-2-6

Heat Dissipation

During Start 4.5 watts per ampere
 During Run
 ASAB-0023B ~ ASAB-0053B ≤ 39 watts approx
 ASAB-0076B ~ ASAB-0105B ≤ 51 watts approx
 ASAB-0145B ~ ASAB-0220B ≤ 120 watts approx
 ASAB-0255B ~ ASAB-0500B ≤ 140 watts approx
 ASAB-0580B ~ ASAB-1000B ≤ 357 watts approx
 ASAB-0255C ~ ASAB-1600C 4.5 watts per ampere approx

Certification

C✓ IEC 60947-4-2
 CCC GB 14048.6 (CNCA-01C-011:2007)
 CE IEC 60947-4-2
 GOST GOST R 50030.4.1-2002
 RoHS Compliant with EU Directive 2002/95/EC
 UL / C-UL UL 508
 ASAB-0023B ~ ASAB-0105B IP20 & NEMA1, UL Indoor Type 1
 ASAB-0145B ~ ASAB-1600C IP00, UL Indoor Open Type
 Marine Lloyds Marine No 1 Specification

4 Installation

4.1 Physical Installation

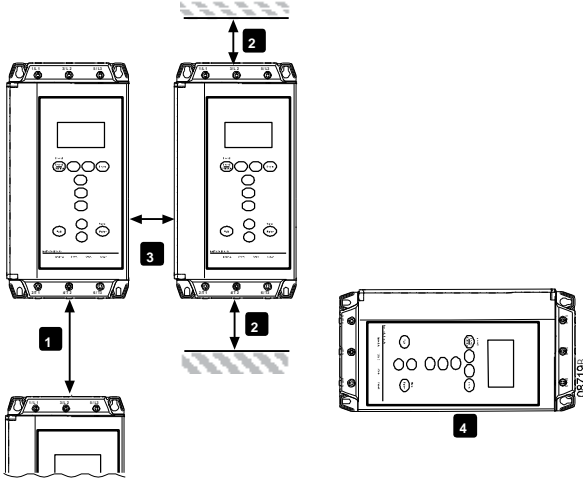

1	ASAB-0023B ~ ASAB-0220B: Allow 100 mm (3.94 inches) between soft starters. ASAB-0255B ~ ASAB-1000B: Allow 200 mm (7.88 inches) between soft starters. ASAB-0255C: Allow 100 mm (3.94 inches) between soft starters. ASAB-0380C ~ ASAB-1600C: Allow 200 mm (7.88 inches) between soft starters.
2	ASAB-0023B ~ ASAB-0220B: Allow 50 mm (1.97 inches) between the soft starter and solid surfaces. ASAB-0255B ~ ASAB-1000B: Allow 200 mm (7.88 inches) between the soft starter and solid surfaces. ASAB-0255C: Allow 100 mm (3.94 inches) between the soft starter and solid surfaces. ASAB-0380C ~ ASAB-1600C: Allow 200 mm (7.88 inches) between the soft starter and solid surfaces.
3	Soft starters may be mounted side by side with no clearance (that is, if mounted without communications modules).
4	The soft starter may be mounted on its side. Derate the soft starter's rated current by 15%.

4.2 Control Terminals

Control terminations use 2.5mm² plug-in terminal blocks. Unplug each block, complete the wiring, then reinsert the block.

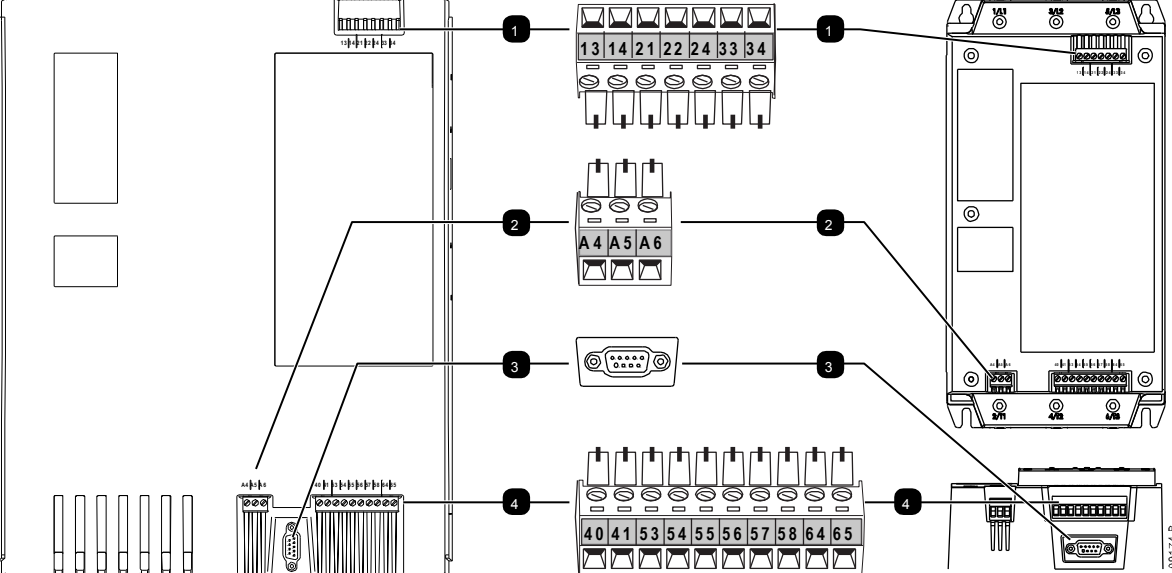

1	Relay outputs	4	Inputs and outputs
13, 14	Relay output A	54, 55	Start
21, 22, 24	Relay output B	56, 57	Stop
33, 34	Relay output C	58, 57	Reset
2	Control voltage (model dependent)	53, 55	Programmable input A
A5, A6	110~120 VAC	64, 65	Motor thermistor input
A4, A6	220~240 VAC	40, 41	Analog output
A5, A6	24 VAC/VDC	55, 41	24 VDC output
3	DB9 connector for remote control panel		



NOTE

If you are not using a thermistor, do not short terminals 64, 65.



NOTE

The DB9 connector on the soft starter should only be used to connect to a remote control panel. Connecting other equipment to this port can damage the soft starter or the equipment.

4.3 Control Voltage

Different models require control voltage to different terminals:

- 12 (110~120 VAC) A5, A6
- 12 (220~240 VAC) A4, A6
- 14 (24 VAC/VDC) A5, A6

4.4 Control Wiring

The ASAB has three fixed inputs for remote control. These inputs should be controlled by contacts rated for low voltage, low current operation (gold flash or similar).

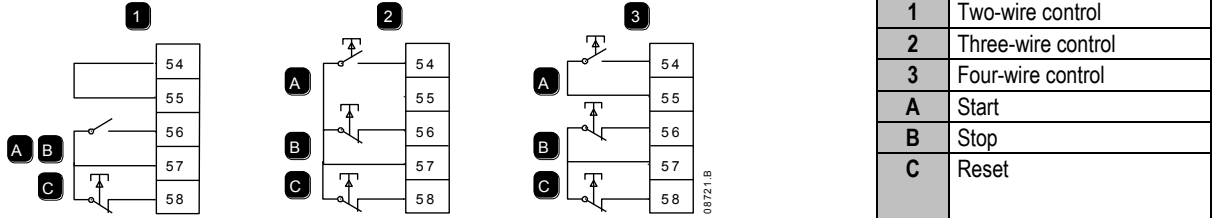

CAUTION

Do not apply voltage to the control input terminals. These are active 24 VDC inputs and must be controlled with potential free contacts.

Cables to the control inputs must be segregated from mains voltage and motor cabling.

4.5 Relay Outputs

The ASAB has three programmable relay outputs.

Operation of the programmable outputs is determined by the settings of parameters 7A~7I.

- If assigned to Main Contactor, the output activates as soon as the soft starter receives a start command and remains active while the soft starter is controlling the motor (until the motor starts a coast to stop, or until the end of a soft stop).
- If assigned to Run, the output activates when the soft start is complete (when the starting current falls below 120% of the programmed motor full load current) and remains closed until the beginning of a stop (either soft stop or coast to stop).
- If assigned to a trip function, the output activates when a trip occurs.
- If assigned to a flag, the output activates when the specified flag is active (parameters 7J~7L).



CAUTION

Some electronic contactor coils are not suitable for direct switching with PCB mount relays. Consult the contactor manufacturer/supplier to confirm suitability.

4.6 Motor Thermistors

Motor thermistors can be connected directly to the ASAB. The soft starter will trip when the resistance of the thermistor circuit exceeds approximately 3.6 k Ω or falls below 20 Ω .

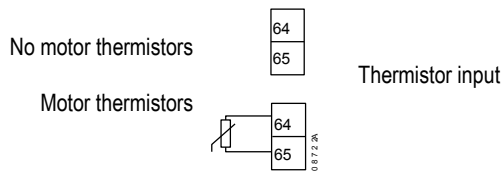

NOTE

If no motor thermistors are connected to the ASAB thermistor input terminals 64, 65 must be open. If 64, 65 are shorted, the ASAB will trip.

The thermistor circuit should be run in screened cable and must be electrically isolated from earth and all other power and control circuits.

4.7 Power Terminations



NOTE

For personnel safety, the power terminals on models up to ASAB-0105B are protected by snap-off tabs. When using large cables, it may be necessary to break off these tabs.



NOTE

Some units use aluminium busbars. When connecting power terminations, we recommend cleaning the surface contact area thoroughly (using an emery or stainless steel brush) and using an appropriate jointing compound to prevent corrosion.

Use only copper stranded or solid conductors, rated for 75 °C or higher.

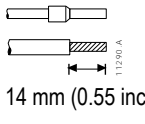
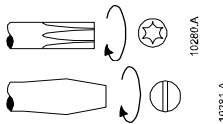
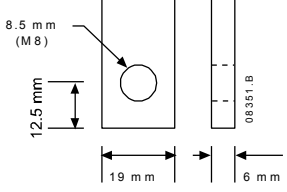
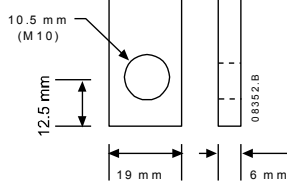
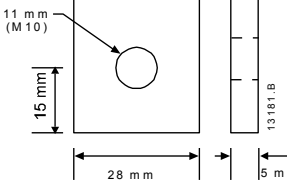
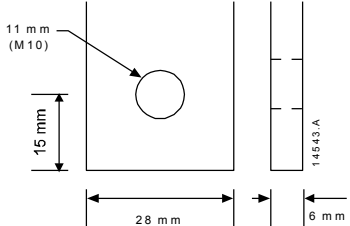
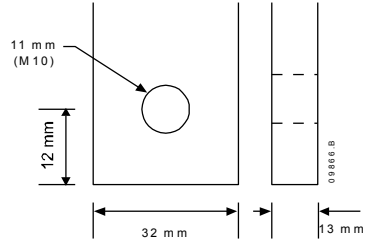
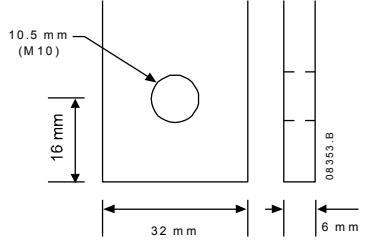
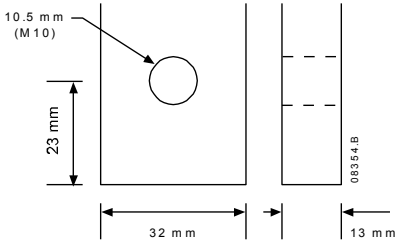
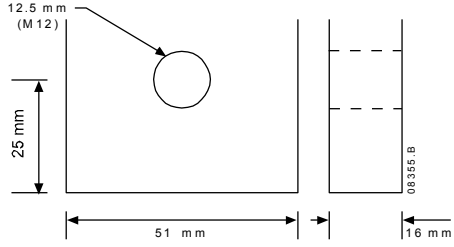
ASAB-0023B~ASAB-0105B		
 <p>Cable size: 6-50 mm² (AWG 10-1/0) Torque: 4 Nm (2.9 ft-lb)</p>	 <p>14 mm (0.55 inch)</p>	 <p>Torx T20 x 150 Flat 7 mm x 150</p>
<p>ASAB-0145B</p> <p>19 Nm (14.0 ft-lb)</p>  <p>8.5 mm (M8) 12.5 mm 19 mm 6 mm 08351.B</p>	<p>ASAB-0170B~ASAB-0220B</p> <p>38 Nm (28.0 ft-lb)</p>  <p>10.5 mm (M10) 12.5 mm 19 mm 6 mm 08352.B</p>	<p>ASAB-0255B</p> <p>38 Nm (28.0 ft-lb)</p>  <p>11 mm (M10) 15 mm 28 mm 5 mm 13181.B</p>
<p>ASAB-0350B~ASAB-0425B</p> <p>38 Nm (28.0 ft-lb)</p>  <p>11 mm (M10) 15 mm 28 mm 6 mm 14543.A</p>	<p>ASAB-0500B~ASAB-1000B</p> <p>38 Nm (28.0 ft-lb)</p>  <p>11 mm (M10) 12 mm 32 mm 13 mm 08866.B</p>	<p>ASAB-0255C</p> <p>38 Nm (28.0 ft-lb)</p>  <p>10.5 mm (M10) 16 mm 32 mm 6 mm 08353.B</p>
<p>ASAB-0380C~ASAB-0930C</p> <p>38 Nm (28.0 ft-lb)</p>  <p>10.5 mm (M10) 23 mm 32 mm 13 mm 08354.B</p>	<p>ASAB-1200C~ASAB-1600C</p> <p>66 Nm (48.7 ft-lb)</p>  <p>12.5 mm (M12) 25 mm 51 mm 16 mm 08355.B</p>	

4.8 Power Input and Output Configurations

4.8.1 Internally Bypassed Models (ASAB-0023B~ASAB-1000B)

Models ASAB-0023B ~ ASAB-0220B have power inputs at the top of the unit and outputs at the bottom of the unit.

Internally bypassed models ASAB-0255B ~ ASAB-0425B have output busbars at the bottom of the unit and input busbars at both the top and bottom of the unit. The AC supply can be connected 'Top in, Bottom out' or 'Bottom in, Bottom out'.

Internally bypassed models ASAB-0500B ~ ASAB-1000B have input and output busbars at the top and bottom of the unit. The AC supply can be connected 'Top in, Bottom out', 'Top in, Top out', 'Bottom in, Bottom out' or 'Bottom in, Top out'.

ASAB-0023B~
ASAB-0105B

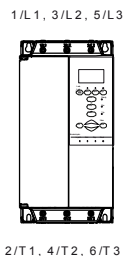

ASAB-0145B~ASAB-0220B

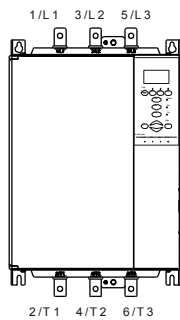

ASAB-0255B~ASAB-0425B

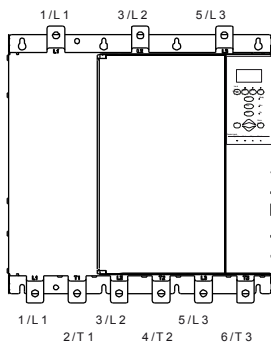

ASAB-0500B~ASAB-1000B

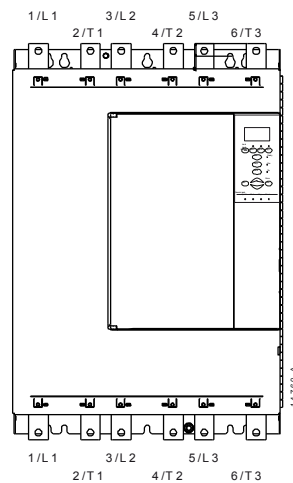

4.8.2 ASAB-0255C

ASAB-0255C has dedicated bypass terminals at the bottom of the unit. The bypass terminals are T1B, T2B, T3B.

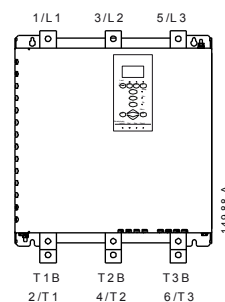

4.8.3 ASAB-0380C~ASAB-1600C

ASAB-0380C~ASAB-1600C have dedicated bypass terminals, on the input busbars. The bypass terminals are L1B, L2B, L3B.

The busbars on non-bypassed models ASAB-0380C ~ ASAB-1600C can be adjusted for top or bottom input and output as required. Refer to Busbar Adjustment Procedure for step-by-step instructions. All units are manufactured top in/bottom out.

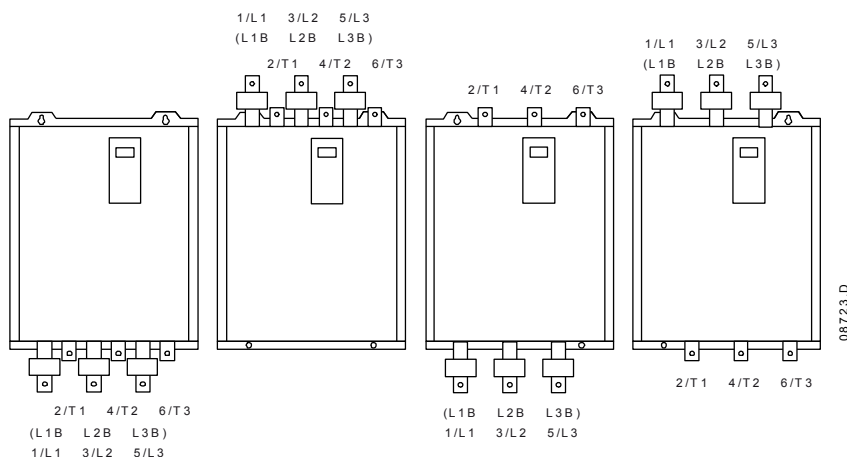

4.9 Schematic Diagrams

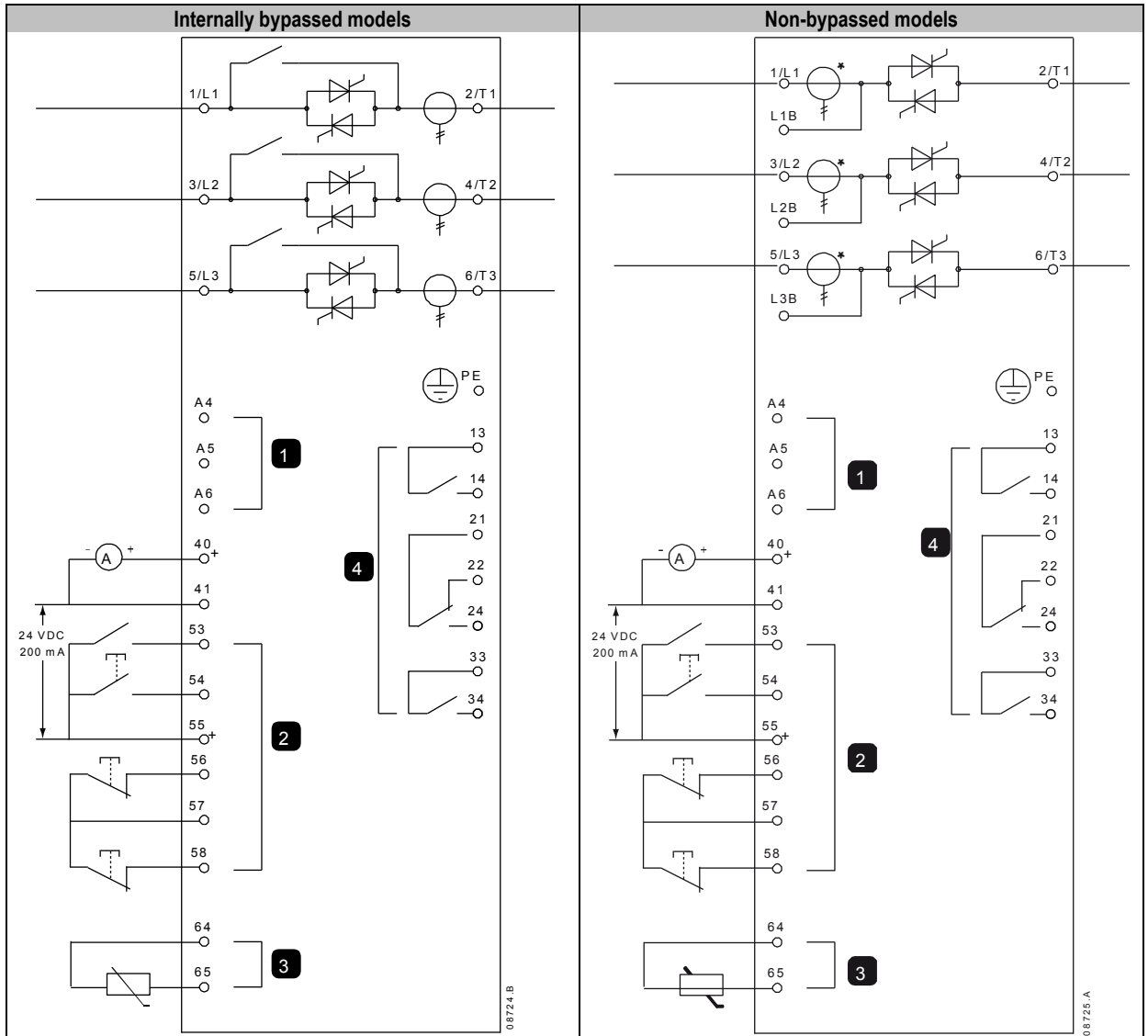

1	Control voltage (model dependent)
2	Remote control inputs
3	Motor thermistor input
4	Relay outputs
40, 41	Analog output
55, 41	24 VDC output

54, 55	Start
56, 57	Stop
58, 57	Reset
53, 55	Programmable input A
13, 14	Relay output A
21, 22, 24	Relay output B
33, 34	Relay output C



NOTE

Different models require control voltage to different terminals:

- 12 (110~120 VAC) A5, A6
- 12 (220~240 VAC) A4, A6
- 14 (24 VAC/VDC) A5, A6



NOTE

* ASAB-0255C current transformers are located on the output. Bypass terminals are labelled T1B, T2B and T3B.

5 Power Circuits

5.1 Motor Connection

ASAB soft starters can be connected to the motor in-line or inside delta (also called three-wire and six-wire connection). When connecting in inside delta, enter the motor full load current (FLC) for parameter 1A. The ASAB will automatically detect whether the motor is connected in-line or inside delta and will calculate the correct inside delta current level.

5.1.1 Testing the Installation

The ASAB can be connected to a small motor for testing. During this test, the soft starter's control input and relay output protection settings can be tested. This test mode is not suitable for testing soft starting or soft stopping performance.

The FLC of the test motor must be at least 2% of the soft starter's minimum FLC (refer to *Minimum and Maximum Current Settings* on page 8).



NOTE

When testing the soft starter with a small motor, set parameter 1A *Motor Full Load Current* to the minimum allowable value.

Models which are internally bypassed do not require an external bypass contactor.

5.1.2 In-line installation, internally bypassed

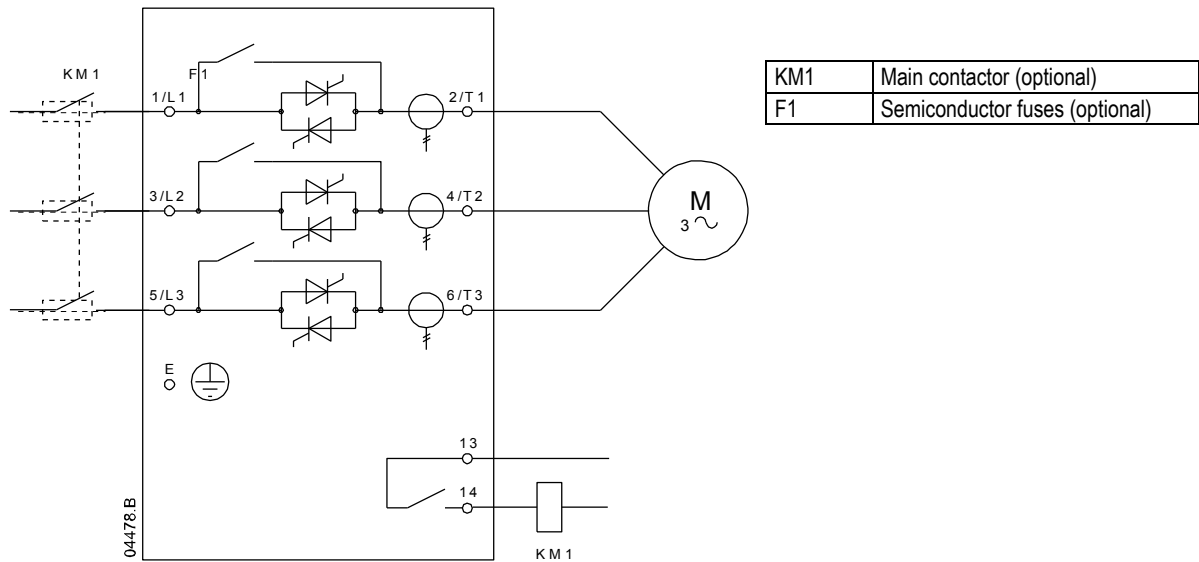

5.1.3 In-line installation, externally bypassed

Non-bypassed models have dedicated bypass terminals, which allow the ASAB to continue providing protection and monitoring functions even when bypassed via an external bypass contactor.

The bypass contactor must be connected to the bypass terminals and controlled by a programmable output configured to Run (refer to parameters 7A~7I).

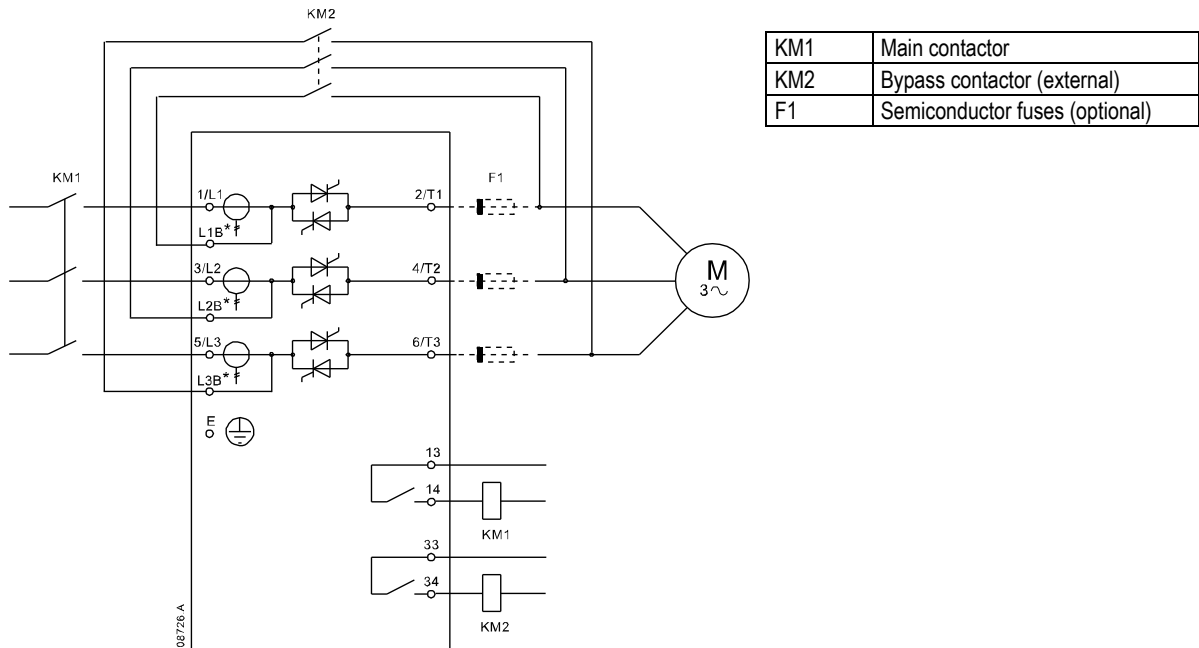

NOTE

The bypass terminals on ASAB-0255C are T1B, T2B, T3B. The bypass terminals on ASAB-0380C ~ ASAB-1600C are L1B, L2B, L3B.

The fuses can be installed on the input side if required.

5.1.4 In-line installation, non-bypassed

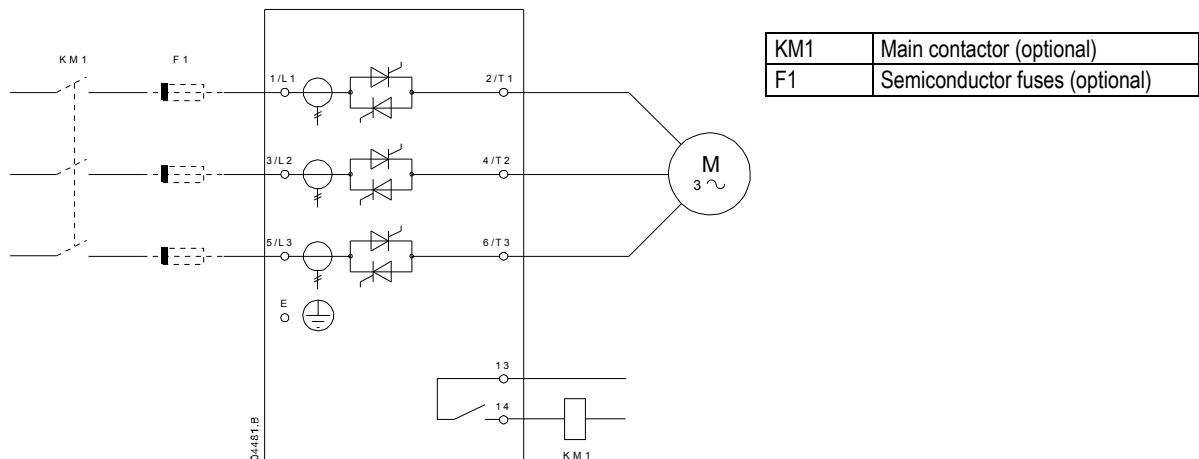

5.1.5 Inside delta installation, internally bypassed

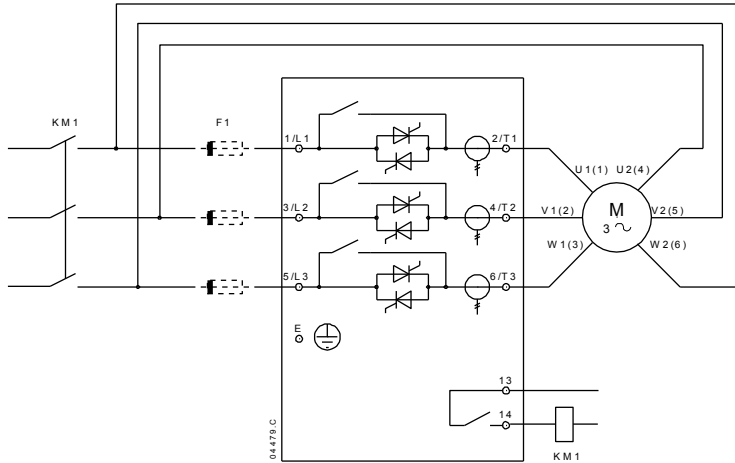

KM1	Main contactor
F1	Semiconductor fuses (optional)



CAUTION

When connecting the ASAB in inside delta configuration, always install a main contactor or shunt trip circuit breaker.

5.1.6 Inside delta installation, externally bypassed

Non-bypassed models have dedicated bypass terminals, which allow the ASAB to continue providing protection and monitoring functions even when bypassed via an external bypass contactor.

The bypass contactor must be connected to the bypass terminals and controlled by a programmable output configured to Run (refer to parameters 7A-7I).

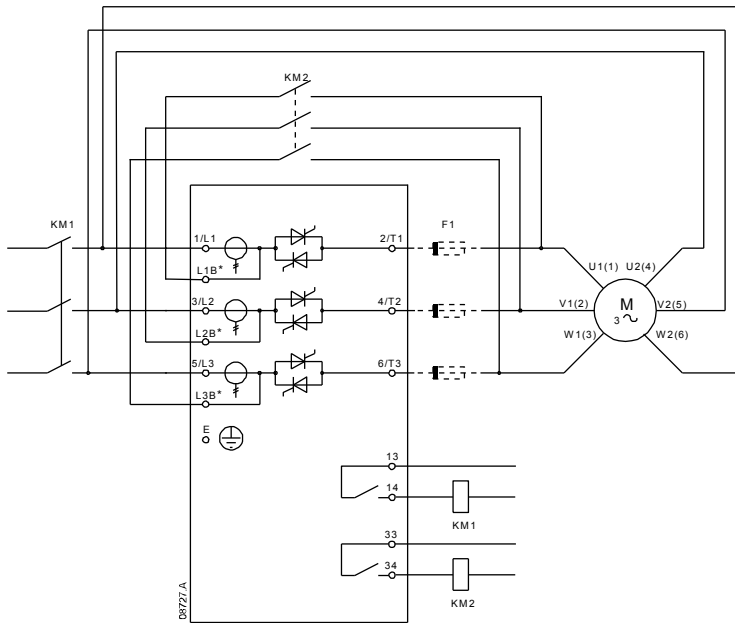

KM1	Main contactor
KM2	Bypass contactor (external)
F1	Semiconductor fuses (optional)



NOTE

The bypass terminals on ASAB-0255C are T1B, T2B, T3B. The bypass terminals on ASAB-0380C ~ ASAB-1600C are L1B, L2B, L3B.

The fuses can be installed on the input side if required.



CAUTION

When connecting the ASAB in inside delta configuration, always install a main contactor or shunt trip circuit breaker.

5.1.7 Inside delta installation, non-bypassed

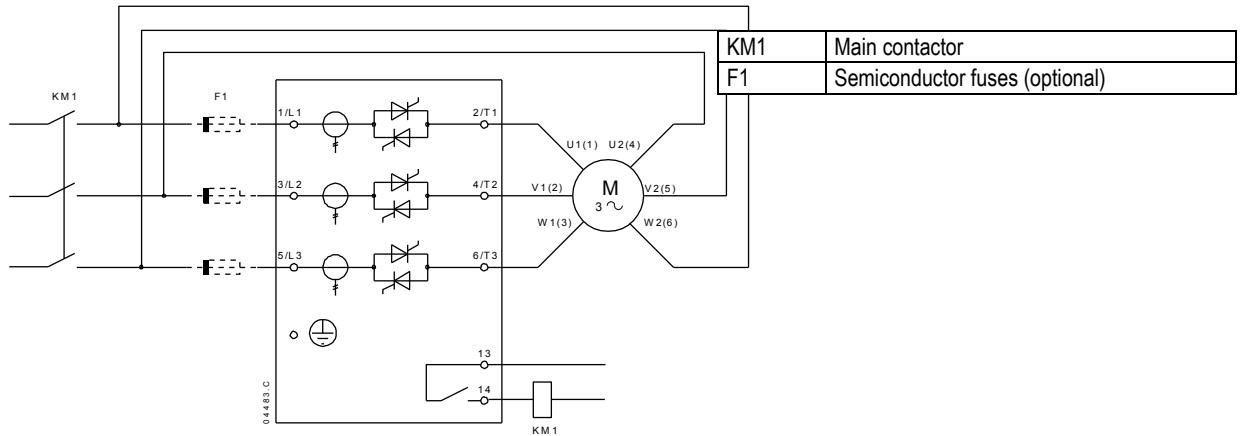

CAUTION

When connecting the ASAB in inside delta configuration, always install a main contactor or shunt trip circuit breaker.

5.2 Bypass Contactor

Some ASAB soft starters are internally bypassed and do not require an external bypass contactor.

Non-bypassed soft starters may be installed with an external bypass contactor. Select a contactor with an AC1 rating greater than or equal to the full load current rating of the connected motor.

5.3 Main Contactor

A main contactor must be installed if the ASAB is connected to the motor in inside delta format and is optional for in-line connection. Select a contactor with an AC3 rating greater than or equal to the full load current rating of the connected motor.

5.4 Circuit Breaker

A shunt trip circuit breaker may be used instead of a main contactor to isolate the motor circuit in the event of a soft starter trip. The shunt trip mechanism must be powered from the supply side of the circuit breaker or from a separate control supply.

5.5 Earth Terminals

Earth terminals are located at the back of the soft starter.

- ASAB-0023B ~ ASAB-0105B have one terminal on the input side (top).
- ASAB-0145B ~ ASAB-1000B and ASAB-0255C ~ ASAB-1600C have two terminals, one on the input side (top) and one on the output side (bottom).

5.6 Power Factor Correction

If power factor correction is used, a dedicated contactor should be used to switch in the capacitors.



CAUTION

Power factor correction capacitors must be connected to the input side of the soft starter. Connecting power factor correction capacitors to the output side will damage the soft starter.

5.7 Power Supply Fuses

Semiconductor fuses can be used for Type 2 coordination (according to IEC 60947-4-2 standard) and to reduce the risk of damage to SCRs from transient overload currents.

HRC fuses (such as Ferraz AJT fuses) can be used for Type 1 coordination according to IEC 60947-4-2 standard.



CAUTION

Adaptive Control controls the motor's speed profile, within the programmed time limit. This may result in a higher level of current than traditional control methods.

For applications using Adaptive Control to soft stop the motor with stop times greater than 30 seconds, motor branch protection should be selected as follows:

- standard HRC line fuses: minimum 150% motor full load current
- motor rated line fuses: minimum rating 100/150% motor full load current
- motor control circuit breaker minimum long time setting: 150% motor full load current
- motor control circuit breaker minimum short time setting: 400% motor full load current for 30 seconds



NOTE

Fuse selection is based on a 400% FLC start for 20 seconds in conjunction with standard published starts per hour, duty cycle, 40°C ambient temperature and up to 1000 m altitude. For installations operating outside these conditions, consult your local supplier.

These fuse tables contain recommendations only. Always consult your local supplier to confirm the selection for your particular application.

5.7.2 Bussman Fuses - Square Body (170M)

Model	SCR I ² T (A ² S)	Supply Voltage (≤ 440 VAC)	Supply Voltage (≤ 575 VAC)	Supply Voltage (≤ 690 VAC)
ASAB-0023B	1150	170M1314	170M1314	170M1314
ASAB-0043B	8000	170M1316	170M1316	170M1316
ASAB-0053B	15000	170M1318	170M1318	170M1318
ASAB-0076B	15000	170M1319	170M1319	170M1318
ASAB-0097B	51200	170M1321	170M1321	170M1319
ASAB-0100B	80000	170M1321	170M1321	170M1321
ASAB-0105B	125000	170M1321	170M1321	170M1321
ASAB-0145B	125000	170M1321	170M1321	170M1321
ASAB-0170B	320000	170M2621	170M2621	170M2621
ASAB-0200B	320000	170M2621	170M2621	170M2621
ASAB-0220B	320000	170M2621	170M2621	170M2621
ASAB-0255B	320000	170M2621	170M2621	170M2621
ASAB-0255C	320000	170M2621	170M2621	170M2621
ASAB-0350B	202000	170M5011	170M5011	—
ASAB-0380C	320000	170M6011	170M6011	—
ASAB-0425B	320000	170M6011	—	—
ASAB-0430C	320000	170M6011	170M6011	—
ASAB-0500B	320000	170M6008*	—	—
ASAB-0580B	781000	170M6013	170M6013	170M6013
ASAB-0620C	1200000	170M6015	170M6015	170M6014
ASAB-0650C	1200000	170M6015	170M6015	170M6014
ASAB-0700B	781000	170M5015	170M5015	—
ASAB-0790C	2530000	170M6017	170M6017	170M6016
ASAB-0820B	1200000	170M5017	170M6015	—
ASAB-0920B	2530000	170M6017	170M6017	—
ASAB-0930C	4500000	170M6019	170M6019	170M6019
ASAB-1000B	2530000	170M6018	170M6013*	—
ASAB-1200C	4500000	170M6021	—	—
ASAB-1410C	6480000	—	—	—
ASAB-1600C	12500000	170M6019*	—	—

* Two parallel connected fuses required per phase.

5.7.3 Bussman Fuses - British Style (BS88)

Model	SCR I ² T (A ² S)	Supply Voltage (≤ 440 VAC)	Supply Voltage (≤ 575 VAC)	Supply Voltage (≤ 690 VAC)
ASAB-0023B	1150	63FE	63FE	63FE
ASAB-0043B	8000	120FEE	120FEE	120FEE
ASAB-0053B	15000	200FEE	200FEE	200FEE
ASAB-0076B	15000	200FEE	200FEE	200FEE
ASAB-0097B	51200	200FEE	200FEE	200FEE
ASAB-0100B	80000	280FM	280FM	280FM
ASAB-0105B	125000	280FM	280FM	280FM
ASAB-0145B	125000	280FM	280FM	280FM
ASAB-0170B	320000	450FMM	450FMM	450FMM
ASAB-0200B	320000	450FMM	450FMM	450FMM
ASAB-0220B	320000	450FMM	450FMM	450FMM
ASAB-0255B	320000	450FMM	450FMM	450FMM
ASAB-0255C	320000	450FMM	450FMM	450FMM
ASAB-0350B	202000	315FM*	—	—
ASAB-0380C	320000	—	—	—

ASAB-0380C	320000	400FMM*	400FMM	400FMM*
ASAB-0425B	320000	400FMM*	—	—
ASAB-0430C	320000	—	—	—
ASAB-0500B	320000	450FMM*	—	—
ASAB-0580B	781000	500FMM*	500FMM*	500FMM*
ASAB-0620C	1200000	630FMM*	630FMM*	—
ASAB-0650C	1200000	630FMM*	630FMM*	—
ASAB-0700B	781000	630FMM*	—	—
ASAB-0790C	2530000	—	—	—
ASAB-0820B	1200000	—	—	—
ASAB-0920B	2530000	—	—	—
ASAB-0930C	4500000	—	—	—
ASAB-1000B	2530000	—	—	—
ASAB-1200C	4500000	—	—	—
ASAB-1410C	6480000	—	—	—
ASAB-1600C	12500000	—	—	—

* Two parallel connected fuses required per phase.

5.7.4 Ferraz Fuses - HSJ

Model	SCR I ² T (A ² S)	Supply Voltage (≤ 440 VAC)	Supply Voltage (≤ 575 VAC)	Supply Voltage (≤ 690 VAC)
ASAB-0023B	1150	HSJ40**	HSJ40**	Not suitable
ASAB-0043B	8000	HSJ80**	HSJ80**	
ASAB-0053B	15000	HSJ110**	HSJ110**	
ASAB-0076B	15000	HSJ125**	HSJ125**	
ASAB-0097B	51200	HSJ175	HSJ175**	
ASAB-0100B	80000	HSJ175	HSJ175	
ASAB-0105B	125000	HSJ225	HSJ225	
ASAB-0145B	125000	HSJ250	HSJ250**	
ASAB-0170B	320000	HSJ300	HSJ300	
ASAB-0200B	320000	HSJ350	HSJ350	
ASAB-0220B	320000	HSJ400**	HSJ400**	
ASAB-0255B	320000	HSJ450**	HSJ450**	
ASAB-0255C	320000	HSJ450**	HSJ450**	
ASAB-0350B	202000	HSJ500**		
ASAB-0380C	320000	Not suitable	Not suitable	
ASAB-0425B	320000			
ASAB-0430C	320000			
ASAB-0500B	320000			
ASAB-0580B	781000			
ASAB-0620C	1200000			
ASAB-0650C	1200000			
ASAB-0700B	781000			
ASAB-0790C	2530000			
ASAB-0820B	1200000			
ASAB-0920B	2530000			
ASAB-0930C	4500000			
ASAB-1000B	2530000			
ASAB-1200C	4500000			
ASAB-1410C	6480000			
ASAB-1600C	12500000			

** Two series connected fuses required per phase.

5.7.5 Ferraz Fuses - North American Style (PSC 690)

Model	SCR I ² T (A ² S)	Supply Voltage (≤ 440 VAC)	Supply Voltage (≤ 575 VAC)	Supply Voltage (≤ 690 VAC)
ASAB-0023B	1150	A070URD30XXX0063	A070URD30XXX0063	—
ASAB-0043B	8000	A070URD30XXX0125	A070URD30XXX0125	A070URD30XXX0125
ASAB-0053B	15000	A070URD30XXX0125	A070URD30XXX0125	A070URD30XXX0125

ASAB-0076B	15000	A070URD30XXX0160	A070URD30XXX0160	A070URD30XXX0160
ASAB-0097B	51200	A070URD30XXX0200	A070URD30XXX0200	A070URD30XXX0200
ASAB-0100B	80000	A070URD30XXX0200	A070URD30XXX0200	A070URD30XXX0200
ASAB-0105B	125000	A070URD30XXX0315	A070URD30XXX0315	A070URD30XXX0315
ASAB-0145B	125000	A070URD30XXX0315	A070URD30XXX0315	A070URD30XXX0315
ASAB-0170B	320000	A070URD30XXX0315	A070URD30XXX0315	A070URD30XXX0315
ASAB-0200B	320000	A070URD30XXX0450	A070URD30XXX0450	A070URD30XXX0450
ASAB-0220B	320000	A070URD30XXX0450	A070URD30XXX0450	A070URD30XXX0450
ASAB-0255C	320000	A070URD30XXX0450	A070URD30XXX0450	A070URD30XXX0450
ASAB-0255B	320000	A070URD30XXX0450	A070URD30XXX0450	A070URD30XXX0450
ASAB-0255C	320000	A070URD30XXX0450	A070URD30XXX0450	A070URD30XXX0450
ASAB-0350B	202000	A070URD31XXX0550	—	—
ASAB-0380C	320000	A070URD33XXX0700	A070URD33XXX0700	—
ASAB-0425B	238000	A070URD32XXX0630	—	—
ASAB-0430C	320000	A070URD33XXX0700	A070URD33XXX0700	—
ASAB-0500B	320000	A070URD32XXX0700	—	—
ASAB-0580B	781000	A070URD32XXX0800	—	—
ASAB-0620C	1200000	A070URD33XXX1000	A070URD33XXX1000	A070URD33XXX1000
ASAB-0650C	1200000	A070URD33XXX1000	A070URD33XXX1000	A070URD33XXX1000
ASAB-0700B	781000	A070URD33XXX0900	—	—
ASAB-0790C	2530000	A070URD33XXX1400	A070URD33XXX1400	A070URD33XXX1400
ASAB-0820B	1200000	A070URD33XXX1100	—	—
ASAB-0920B	2530000	A070URD33XXX1250	—	—
ASAB-0930C	4500000	A070URD33XXX1400	A070URD33XXX1400	A070URD33XXX1400
ASAB-1000B	2530000	A070URD33XXX1400	—	—
ASAB-1200C	4500000	A055URD33XXX2250	—	—
ASAB-1410C	6480000	A055URD33XXX2250	—	—
ASAB-1600C	12500000	—	—	—

XXX = blade type. Refer to Ferraz catalog for details.

5.7.6 Ferraz Fuses - European Style (PSC 690)

Model	SCR I ² T (A ² S)	Supply Voltage (≤ 440 VAC)	Supply Voltage (≤ 575 VAC)	Supply Voltage (≤ 690 VAC)
ASAB-0023B	1150	6.9URD30D11A0050	6.9URD30D11A0050	6.9URD30D11A0050
ASAB-0043B	8000	6.9URD30D11A0125	6.9URD30D11A0125	6.9URD30D11A0125
ASAB-0053B	15000	6.9URD30D11A0125	6.9URD30D11A0125	6.9URD30D11A0125
ASAB-0076B	15000	6.9URD30D11A0160	6.9URD30D11A0160	6.9URD30D11A0160
ASAB-0097B	51200	6.9URD30D11A0200	6.9URD30D11A0200	6.9URD30D11A0200
ASAB-0100B	80000	6.9URD30D11A0200	6.9URD30D11A0200	6.9URD30D11A0200
ASAB-0105B	125000	6.9URD30D11A0315	6.9URD30D11A0315	6.9URD30D11A0315
ASAB-0145B	125000	6.9URD30D11A0315	6.9URD30D11A0315	6.9URD30D11A0315
ASAB-0170B	320000	6.9URD30D11A0315	6.9URD30D11A0315	6.9URD30D11A0315
ASAB-0200B	320000	6.9URD31D11A0450	6.9URD31D11A0450	6.9URD31D11A0450
ASAB-0220B	320000	6.9URD31D11A0450	6.9URD31D11A0450	6.9URD31D11A0450
ASAB-0255B	320000	6.9URD31D11A0450	6.9URD31D11A0450	6.9URD31D11A0450
ASAB-0255C	320000	6.9URD31D11A0450	6.9URD31D11A0450	6.9URD31D11A0450
ASAB-0350B	202000	6.9URD31D11A0550	—	—
ASAB-0380C	320000	6.9URD33D11A0700	6.9URD33D11A0700	6.9URD33D11A0700
ASAB-0425B	320000	6.9URD32D11A0630	—	—
ASAB-0430C	320000	6.9URD33D11A0700	6.9URD33D11A0700	6.9URD33D11A0700
ASAB-0500B	320000	6.9URD32D11A0700	—	—
ASAB-0580B	781000	6.9URD32D11A0800	—	—
ASAB-0620C	1200000	6.9URD33D11A1000	6.9URD33D11A1000	6.9URD33D11A1000
ASAB-0650C	1200000	6.9URD33D11A1000	6.9URD33D11A1000	6.9URD33D11A1000
ASAB-0700B	781000	6.9URD33D11A0900	—	—
ASAB-0790C	2530000	6.6URD33D11A1400	6.6URD33D11A1400	—
ASAB-0820B	1200000	6.9URD33D11A1100	—	—
ASAB-0920B	2530000	6.9URD33D11A1250	—	—
ASAB-0930C	4500000	6.6URD33D11A1400	6.6URD33D11A1400	—

ASAB-1000B	2530000	6.9URD33D11A1400	—	—
ASAB-1200C	4500000	6URD233PLAF2200	6URD233PLAF2200	—
ASAB-1410C	6480000	6URD233PLAF2200	6URD233PLAF2200	—
ASAB-1600C	12500000	6URD233PLAF2800	6URD233PLAF2800	—

5.7.7 Ferraz Fuses - AJT

Model	SCR I ² T (A ² S)	Supply Voltage (≤ 440 VAC)	Supply Voltage (≤ 575 VAC)	Supply Voltage (≤ 690 VAC)
ASAB-0023B	1150	AJT25	AJT25	Not suitable
ASAB-0043B	8000	AJT50	AJT50	
ASAB-0053B	15000	AJT60	AJT60	
ASAB-0076B	15000	AJT80	AJT80	
ASAB-0097B	512000	AJT100	AJT100	
ASAB-0100B	80000	AJT100	AJT100	
ASAB-0105B	125000	AJT125	AJT125	
ASAB-0145B	125000	AJT150	AJT150	
ASAB-0170B	320000	AJT175	AJT175	
ASAB-0200B	320000	AJT200	AJT200	
ASAB-0220B	320000	AJT250	AJT250	
ASAB-0255C	320000	AJT300	AJT300	
ASAB-0255B	202000	AJT300	AJT300	
ASAB-0350B	202000	AJT400	AJT400	
ASAB-0380C	320000	AJT450	AJT450	
ASAB-0425B	238000	AJT450	AJT450	
ASAB-0430C	320000	AJT450	AJT450	
ASAB-0500B	320000	AJT500	AJT500	
ASAB-0580B	781000	A4BQ800	A4BQ800	
ASAB-0620C	1200000	A4BQ800	A4BQ800	
ASAB-0650C	1200000	A4BQ800	A4BQ800	
ASAB-0700B	781000	A4BQ800	A4BQ800	
ASAB-0790C	2530000	A4BQ1200	A4BQ1200	
ASAB-0820B	1200000	A4BQ1200	A4BQ1200	
ASAB-0920B	2530000	A4BQ1200	A4BQ1200	
ASAB-0930C	4500000	A4BQ1200 / A4BT1100	A4BQ1200 / A4BT1100	
ASAB-1000B	2530000	A4BQ1200	A4BQ1200	
ASAB-1200C	4500000	A4BQ1600	A4BQ1600	
ASAB-1410C	6480000	A4BQ2000	A4BQ2000	
ASAB-1600C	12500000	A4BQ2500 / A4BT1800	A4BQ2500 / A4BT1800	

6 Operation

6.1 Keypad and Feedback

6.1.1 The Keypad

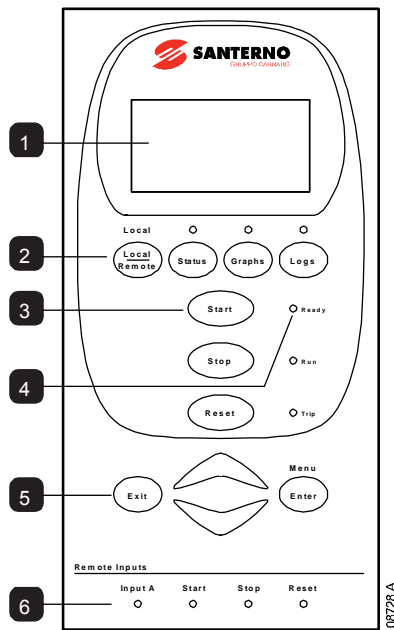

1	Four-line display for status and programming details.
2	LOCAL/REMOTE: Toggle between Local and Remote control STATUS: Open the status displays and scroll between different status screens GRAPHS: Open the performance graphs and scroll between different graph screens LOGS: Open the logs
3	Soft starter local control buttons: START: Start the motor STOP: Stop the motor RESET: Reset a trip (Local mode only).
4	Status LEDs (see below for details)
5	Menu navigation buttons: EXIT: Exit the menu or parameter, or cancel a parameter change. MENU/ENTER: Enter a menu or parameter, or save a parameter change. ▲ ▼: Scroll to the next or previous menu or parameter, change the setting of the current parameter or scroll through the status or graph screens.
6	Remote input LEDs. When on: INPUT A: Programmable input A is active START: The remote start input is active STOP: The remote stop input is active RESET: The remote reset input is active

Starter Status LEDs

LED name	On	Flashing
Ready	The motor is stopped and the starter is ready to start.	The motor is stopped and the starter is waiting for the <i>Restart Delay</i> (parameter 5A) or <i>Motor Temperature Check</i> (parameter 4F).
Run	The motor is in run state (receiving full voltage).	The motor is starting or stopping.
Trip	The starter has tripped.	The starter is in warning state.
Local	The starter is in Local control mode.	–
Status	The status screens are active.	–
Graphs	The graph screens are active.	The graph has been paused.
Logs	The logs menu is open.	–

If the starter is in remote control mode, the Local LED will be off.

If all LEDs are off, the starter is not receiving control voltage.

6.1.2 Displays

The keypad displays a wide range of performance information about the soft starter. The bottom half of the screen shows real-time information on current or motor power (as selected in parameter 10J). Use the **STATUS** button or ▲ and ▼ buttons to select the information shown on the top half of the screen.

- Starter status
- Motor temperature
- Current
- Motor power
- Last start information
- Date and time
- SCR conduction



NOTE

Screens shown here are with the default settings.

Starter Status

The starter status screen shows details of the starter's operating status, motor temperature and motor power.

```

READY
M1 000%      000.0KW
  
```

Programmable screen

The ASAB's user-programmable screen can be configured to show the most important information for the particular application. Use parameters 10B to 10E to select which information to display.

```

READY
0000 HRS
  
```

Motor Temperature

The temperature screen shows which motor data set is in use, and the temperature of both motors as a percentage of total thermal capacity. If the ASAB is configured for use on one motor, the temperature for the secondary motor (M2) will always show 0%.

```

PRIMARY MOTOR SET
▶ M1 000%      M2 000%
  
```

Current

The current screen shows real-time line current on each phase.

```

PHASE CURRENTS
000.0A 000.0A 000.0A
  
```

Motor Power

The motor power screen shows motor power (kW, HP and kVA) and power factor.

```

000.0KW      0000HP
0000KVA      - . - - PF
  
```

Last Start Information

The last start information screen shows details of the most recent successful start:

- start duration (seconds)
- maximum start current drawn (as a percentage of motor full load current)
- calculated rise in motor temperature

```

LAST START      010 S
350 % FLC      Δ TEMP 5%
  
```

Date and Time

The date/time screen shows the current system date and time (24 hour format). For details on setting the date and time, refer to *Set Date and Time* on page 49.

SCR Conduction Bargraph

The SCR conduction bargraph shows the level of conduction on each phase.

```

L1 COND ██████████
L2 COND ██████████
L3 COND ██████████
  
```

6.1.3 Graphs

The ASAB can display real-time performance information for:

- current
- motor temperature
- motor kW
- motor kVA
- motor power factor

The newest information is displayed at the right hand edge of the screen. Older data is not stored.

To access the graphs or to change which graph is shown, press the **GRAPHS** button.

The graph can also be paused, to allow past performance to be analysed. To pause the graph, press and hold the **GRAPHS** button for more than 0.5 seconds. To unpause the graph, press the **GRAPHS** button again.



NOTE

The ASAB will not collect data while the graph is paused. When graphing resumes, a small gap will be shown between the old data and the new data.

6.2 Start, Stop and Reset Commands

The soft starter can be controlled in three ways:

- using the buttons on the keypad
- via remote inputs
- via a serial communication link

The **LOCAL/REMOTE** button controls whether the ASAB will respond to local control (via the keypad) or remote control (via the remote inputs). The ASAB can also be set to allow local control only or remote control only, using parameter 6A *Local/Remote*. The Local LED on the keypad is on when the soft starter is in local control mode and off when the soft starter is in remote control mode.

The **STOP** button on the keypad is always enabled.

Control via the serial communication network is always enabled in local control mode, and can be enabled or disabled in remote control mode (parameter 6B *Comms in Remote*). Control via the serial communication network requires an optional communication module.

6.2.1 Using the Soft Starter to Control a Motor

To soft start the motor, press the **START** button on the keypad or activate the Start remote input. The motor will start using the start mode selected in parameter 2A.

To stop the motor, press the **STOP** button on the keypad or activate the Stop remote input. The motor will stop using the stop mode selected in parameter 2H.

To reset a trip on the soft starter, press the **RESET** button on the keypad or activate the Reset remote input.

To stop the motor with a coast to stop, regardless of the setting of parameter 2H *Stop Mode*, press the local **STOP** and **RESET** buttons at the same time. The soft starter will remove power from the motor and open the main contactor, and the motor will coast to stop.

6.3 Soft Start Methods

Soft starters offer a variety of methods to control motor starting. Each soft start method uses a different primary control parameter.

Soft Start Method	Parameter Controlled	Performance Parameters Influenced
Timed Voltage Ramp	Voltage	Start current, start torque, acceleration
Constant Current	Current	Start torque, acceleration
Torque Control	Torque	Start current, acceleration
Adaptive Control	Acceleration	Start current, start torque

Best results are obtained by selecting the soft start method that directly controls the parameter of most importance for the application. Typically soft starters are used to limit motor start current or control load acceleration and/or deceleration. The ASAB can be set to either Constant Current or Adaptive Control.

To Control	Use
Motor Start Current	Constant Current
Motor/Load Acceleration	Adaptive Control

6.3.1 Constant Current

Constant current is the traditional form of soft starting, which raises the current from zero to a specified level and keeps the current stable at that level until the motor has accelerated.

Constant current starting is ideal for applications where the start current must be kept below a particular level.

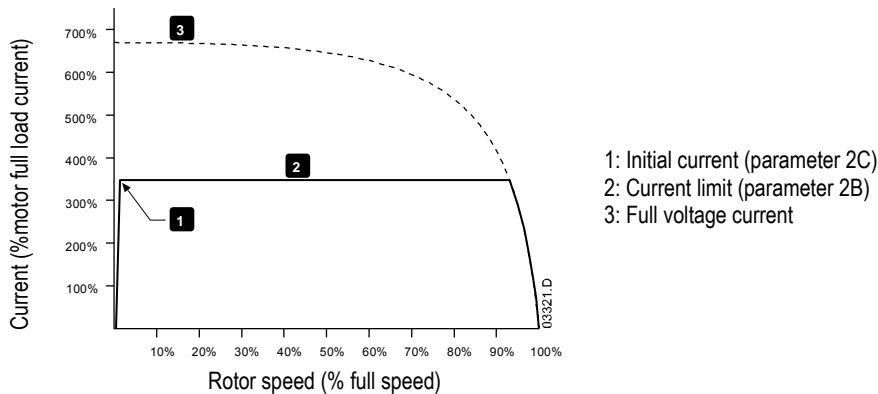

6.3.2 Current Ramp

Current ramp soft starting raises the current from a specified starting level (1) to a maximum limit (3), over an extended period of time (2).

Current ramp starting can be useful for applications where:

- the load can vary between starts (for example a conveyor which may start loaded or unloaded). Set the initial current (parameter 2C) to a level that will start the motor with a light load, and the current limit (parameter 2B) to a level that will start the motor with a heavy load.
- the load breaks away easily, but starting time needs to be extended (for example a centrifugal pump where pipeline pressure needs to build up slowly).
- the electricity supply is limited (for example a generator set), and a slower application of load will allow greater time for the supply to respond.

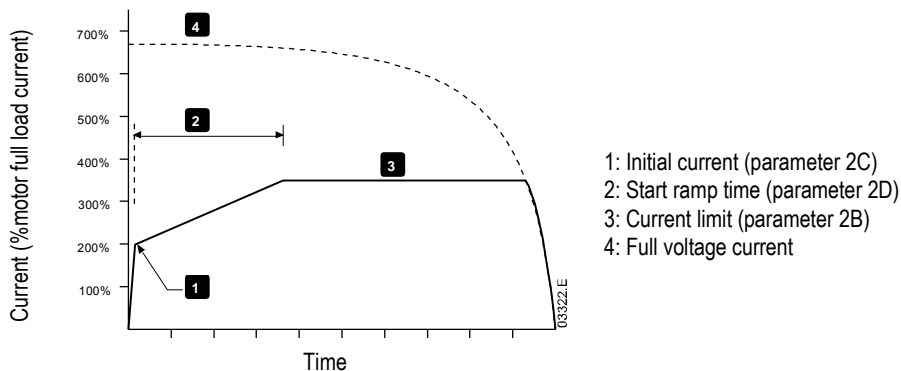

6.3.3 Adaptive Control for Starting

In an adaptive control soft start, the ASAB adjusts the current in order to start the motor within a specified time and using a selected acceleration profile.



CAUTION

Adaptive Control cannot start the motor faster than a direct on-line (DOL) start. If the start ramp time (parameter 2D) is shorter than the motor's DOL start time, starting current may reach DOL levels.

Every application has a particular starting profile, based on characteristics of the load and the motor. Adaptive Control offers three different starting profiles, to suit the requirements of different applications. Selecting a profile that matches the inherent profile of the application can help smooth out acceleration across the full start time. Selecting a dramatically different Adaptive Control profile can somewhat neutralise the inherent profile.

The ASAB monitors the motor's performance during each start, to improve control for future soft starts.

Adaptive Control

To use Adaptive Control to control starting performance:

1. Select Adaptive Control from the Start Mode menu (parameter 2A)
2. Set the desired Start Ramp Time (parameter 2D)

3. Select the desired Adaptive Start Profile (parameter 2J)
4. Set a start Current Limit (parameter 2B) sufficiently high to allow a successful start. The first Adaptive Control start will be a Constant Current start. This allows the ASAB to learn the characteristics of the connected motor. This motor data is used by the ASAB during subsequent Adaptive Control starts.

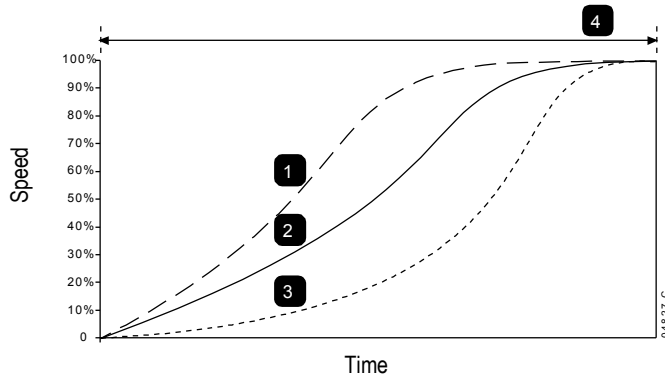

Adaptive start profile (parameter 2J):

1. Early acceleration
2. Constant acceleration
3. Late acceleration
4. Start ramp time (parameter 2D)

How to Select the Adaptive Control Start Profile

The best profile will depend on the exact details of each application.

Some loads, such as submersible pumps, should not be run at slow speeds. An early acceleration profile will raise the speed quickly, then control acceleration through the rest of the start.



NOTE

Adaptive Control will control the load according to the programmed profile. Start current will vary according to the selected acceleration profile and the programmed start time.

If replacing a motor connected to a ASAB programmed for Adaptive Control starting or stopping, or if the starter has been tested on a different motor prior to actual installation, the starter will need to learn the characteristics of the new motor. The ASAB will automatically re-learn the motor's characteristics if parameter 1A *Motor Full Load Current* or parameter 2L *Adaptive Control Gain* is changed.



CAUTION

Adaptive Control controls the motor's speed profile, within the programmed time limit. This may result in a higher level of current than traditional control methods.

Fine-tuning Adaptive Control

If the motor does not start or stop smoothly, adjust the adaptive control gain (parameter 2L). The gain setting determines how much the ASAB will adjust future adaptive control starts and stops, based on information from the previous start. The gain setting affects both starting and stopping performance.

- If the motor accelerates or decelerates too quickly at the end of a start or stop, increase the gain setting by 5%~10%.
- If the motor speed fluctuates during starting or stopping, decrease the gain setting slightly.



NOTE

Changing the gain setting resets the starter's adaptive control learning. The first start after changing the gain will use constant current.

6.3.4 Kickstart

Kickstart provides a short boost of extra torque at the beginning of a start, and can be used in conjunction with current ramp or constant current starting.

Kickstart can be useful to help start loads that require high breakaway torque but then accelerate easily (for example flywheel loads such as presses).

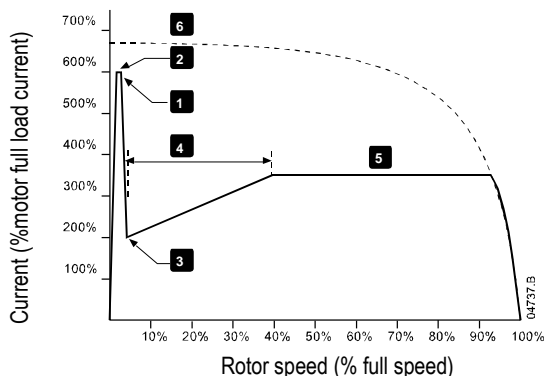

1: Kickstart level (parameter 2E)
 2: Kickstart time (parameter 2F)
 3: Initial current (parameter 2C)
 4: Start ramp time (parameter 2D)
 5: Current limit (parameter 2B)
 6: Full voltage current

6.4 Stop Methods

Soft starters offer a variety of methods for the control of motor stopping.

Stop Method	Performance Result
Coast To Stop	Natural load run down
TVR Soft Stop	Extended run down time
Adaptive Control	Extended run down time according to selected deceleration profile
Brake	Reduced run down time

Soft starters are often used in pumping applications to eliminate the damaging effects of fluid hammer. Adaptive Control should be the preferred stop method for these applications.

6.4.1 Coast to Stop

Coast to stop lets the motor slow at its natural rate, with no control from the soft starter. The time required to stop will depend on the type of load.

6.4.2 TVR Soft Stop

Timed voltage ramp reduces the voltage to the motor gradually over a defined time. The load may continue to run after the stop ramp is complete.

Timed voltage ramp stopping can be useful for applications where the stop time needs to be extended, or to avoid transients on generator set supplies.

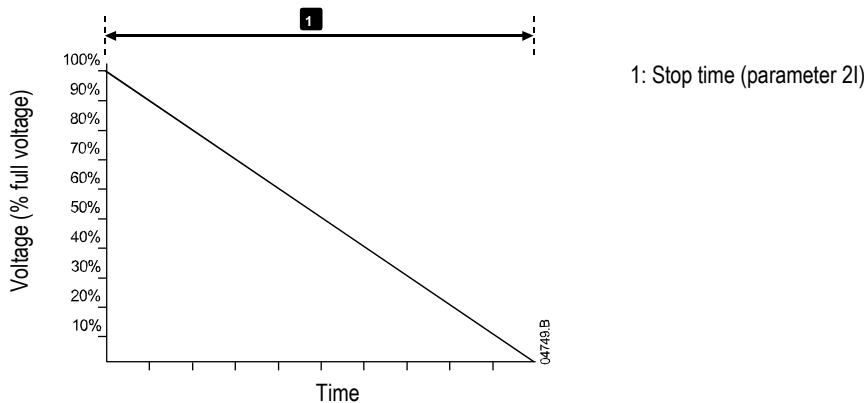

6.4.3 Adaptive Control for Stopping

In an adaptive control soft stop, the ASAB controls the current in order to stop the motor within a specified time and using a selected deceleration profile. Adaptive Control can be useful in extending the stopping time of low inertia loads.



NOTE

Adaptive control does not actively slow the motor down and will not stop the motor faster than a coast to stop. To shorten the stopping time of high inertia loads, use brake.



CAUTION

Adaptive Control controls the motor's speed profile, within the programmed time limit. This may result in a higher level of current than traditional control methods.

Every application has a particular stopping profile, based on characteristics of the load and the motor. Adaptive Control offers three different stopping profiles. Choose the adaptive control profile that best matches your application requirements.

Adaptive Control

To use Adaptive Control to control stopping performance:

1. Select Adaptive Control from the Stop Mode menu (parameter 2H)
2. Set the desired Stop Time (parameter 2I)
3. Select the required Adaptive Stop Profile (parameter 2K)

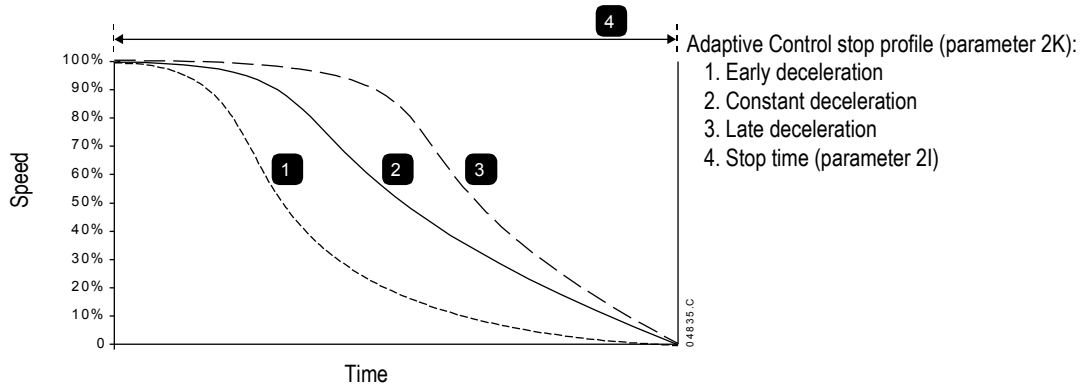

Pump stopping

The hydraulic characteristics of pump systems vary considerably. This variation means the ideal deceleration profile and stop time will vary from application to application. The table provides guidelines on selecting between Adaptive Control deceleration profiles, but we recommend testing the three profiles to identify the best profile for the application.

Adaptive Stop Profile	Application
Late Deceleration	High head systems where even a small decrease in motor/pump speed results in a rapid transition between forward flow and reverse flow.
Constant Deceleration	Low to medium head, high flow applications where the fluid has high momentum.
Early Deceleration	Open pump systems where fluid must drain back through the pump without driving the pump in reverse.

The first Adaptive Control stop will be a normal soft stop. This allows the ASAB to learn the characteristics of the connected motor. This motor data is used by the ASAB during subsequent Adaptive Control stops.



NOTE

Adaptive Control will control the load according to the programmed profile. Stopping current will vary according to the selected deceleration profile and stop time.

If replacing a motor connected to a ASAB programmed for Adaptive Control starting or stopping, or if the starter has been tested on a different motor prior to actual installation, the starter will need to learn the characteristics of the new motor. The ASAB will automatically re-learn the motor's characteristics if parameter 1A *Motor Full Load Current* or parameter 2L *Adaptive Control Gain* is changed.

6.4.4 Brake

Brake reduces the time the motor requires to stop.

During braking an increased noise level from the motor may be audible. This is a normal part of motor braking.

When brake is selected, the ASAB uses DC injection to slow the motor.

ASAB braking:

- Does not require the use of a DC brake contactor
- Controls all three phases so that the braking currents and associated heating are evenly distributed through the motor.



CAUTION

If the brake torque is set too high, the motor will stop before the end of the brake time and the motor will suffer unnecessary heating which could result in damage. Careful configuration is required to ensure safe operation of the starter and motor.

A high brake torque setting can result in peak currents up to motor DOL being drawn while the motor is stopping. Ensure protection fuses installed in the motor branch circuit are selected appropriately.



CAUTION

Brake operation causes the motor to heat faster than the rate calculated by the motor thermal model. If you are using brake, install a motor thermistor or allow sufficient restart delay (parameter 5A).

Braking has two stages:

- Pre-brake: provides an intermediate level of braking to slow motor speed to a point where full brake can be operated successfully (approximately 70% speed).
- Full brake: brake provides maximum braking torque but is ineffective at speeds greater than approximately 70%.

To configure the ASAB for brake operation:

1. Set parameter 2I for the desired stopping time duration (1). This is the total braking time and must be set sufficiently longer than the brake time (parameter 15H) to allow the pre-braking stage to reduce motor speed to approximately 70%. If the stop time is too short, braking will not be successful and the motor will coast to stop.
2. Set Brake Time (parameter 15H) to approximately one quarter of the programmed Stop Time. This sets the time for the Full Brake stage (2).
3. Adjust the Brake Torque (parameter 15G) so that the desired stopping performance is achieved. If set too low, the motor will not stop completely and will coast to stop by the end of the braking period.

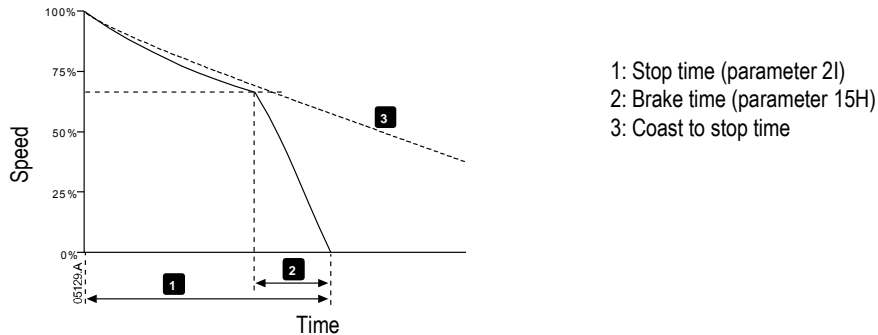

CAUTION

When using DC brake, the mains supply must be connected to the soft starter (input terminals L1, L2, L3) in positive phase sequence and parameter 4B *Phase Sequence* must be set to Positive Only.



NOTE

For loads which may vary between braking cycles, install a zero speed sensor to ensure that the soft starter ends DC braking when the motor stops. This avoids unnecessary heating of the motor.

For more information on using the ASAB with an external speed sensor (eg for applications with variable load during the braking cycle), refer to *DC Brake with External Zero Speed Sensor* on page 56.

6.5 Jog Operation

Jog runs the motor at reduced speed, to allow alignment of the load or to assist servicing. The motor can be jogged in either forward or reverse direction.

The maximum available torque for jog forward is approximately 50%~75% of motor full load torque (FLT) depending on the motor. The torque when the motor is jogged in reverse is approximately 25% to 50% of FLT.

Parameter 15F *Jog Torque* controls how much of the maximum available jog torque the soft starter will apply to the motor.



NOTE

Setting parameter 15F above 50% may cause increased shaft vibration.

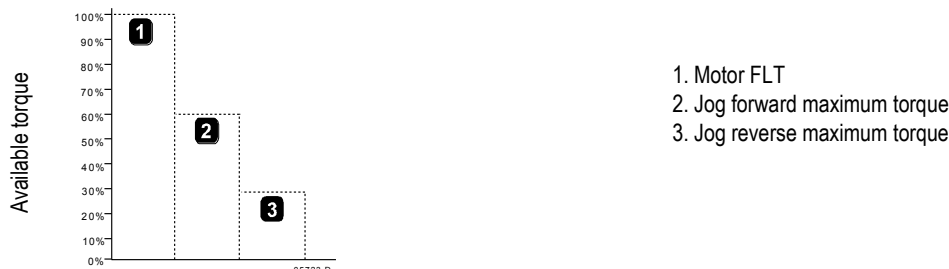

To activate jog operation, use a programmable input (parameter 6D). If any other command is received when jogging the starter will stop and await a new command.



NOTE

Soft start and soft stop are not available during jog operation.

Jog is only available for the primary motor.



CAUTION

Slow speed running is not intended for continuous operation due to reduced motor cooling.

Jog operation causes the motor to heat faster than the rate calculated by the motor thermal model. If you are using jog, install a motor thermistor or allow sufficient restart delay (parameter 5A)

6.6 Inside Delta Operation

Adaptive Control, Jog, Brake and PowerThrough functions are not supported with inside delta (six-wire) operation. If these functions are programmed when the starter is connected inside delta the behaviour is as given below:

Adaptive Control Start	The starter performs a constant current start.
Adaptive Control Stop	The starter performs a TVR soft stop if parameter 21 <i>Stop Time</i> is >0 secs. If parameter 21 is set to 0 secs the starter performs a coast to stop.
Jog	The starter issues a warning with the error message <i>Unsupported Option</i> .
Brake	The starter performs a coast to stop.
PowerThrough	The starter trips with the error message <i>Lx-Tx Shorted</i> .



NOTE

When connected in inside delta, current imbalance is the only phase loss protection that is active during run. Do not disable current imbalance protection (parameter 4A) during inside delta operation.



CAUTION

Inside delta operation is only possible with mains voltage ≤ 600 VAC.

7 Programming Menu

The Programming Menu lets you view and change programmable parameters that control how the ASAB operates.

To open the Programming Menu, press the **MENU/ENTER** button while viewing the status or graph screens.

To navigate through the Programming Menu:

- to scroll through parameter groups, press the **▲** or **▼** button.
- to open a submenu, press the **MENU/ENTER** button.
- to view the parameters in a group, press the **MENU/ENTER** button.
- to return to the previous level, press the **EXIT** button.
- to close the Programming Menu, press **EXIT** repeatedly or press the **STATUS** or **GRAPHS** button.

To change a parameter value:

- scroll to the appropriate parameter in the Programming Menu and press **MENU/ENTER** to enter edit mode.
- to alter the parameter setting, use the **▲** and **▼** buttons. Pressing **▲** or **▼** once will increase or decrease the value by one unit. If the button is held for longer than five seconds, the value will increase or decrease at a faster rate.
- to save changes, press **MENU/ENTER**. The setting shown on the display will be saved and the keypad will return to the parameter list.
- to cancel changes, press **EXIT**. The keypad will ask for confirmation, then return to the parameter list without saving changes.

You can access the Programming Menu at any time, including while the soft starter is running. Any changes to the start profile take effect immediately.

The Programming Menu contains four sub-menus:

Quick Setup Menu	Provides access to quick setup options for common applications.
Standard Menu	The Standard Menu provides access to commonly used parameters, allowing you to configure the ASAB to suit your application.
Extended Menu	The Extended Menu provides access to all the ASAB's programmable parameters, allowing experienced users to take advantage of advanced features.
Setup Tools	Setup Tools includes maintenance options to configure the ASAB's date and time or load a standard parameter set.

7.1 Quick Setup

The Quick Setup Menu makes it easy to configure the ASAB for common applications. The ASAB selects the parameters relevant to the application and suggests a typical setting, and you can adjust each parameter to suit your exact requirements.

Always set parameter 1A *Motor Full Load Current* to match the motor's nameplate full load current. The suggested value is the starter's minimum full load current.

On the display, the highlighted values are suggested values and the values enclosed in a box are the loaded values.

Application	Parameter	Suggested value
Pump Centrifugal	<i>Motor Full Load Current</i> <i>Start Mode</i> <i>Adaptive Start Profile</i> <i>Start Ramp Time</i> <i>Stop Mode</i> <i>Adaptive Stop Profile</i> <i>Stop Time</i>	Model dependent Adaptive Control Early Acceleration 10 seconds Adaptive Control Late Deceleration 15 seconds
Pump Submersible	<i>Motor Full Load Current</i> <i>Start Mode</i> <i>Adaptive Start Profile</i> <i>Start Ramp Time</i> <i>Stop Mode</i> <i>Adaptive Stop Profile</i> <i>Stop Time</i>	Model dependent Adaptive Control Early Acceleration 5 seconds Adaptive Control Late Deceleration 5 seconds
Fan Damped	<i>Motor Full Load Current</i> <i>Start Mode</i> <i>Current Limit</i>	Model dependent Constant Current 350%
Fan Undamped	<i>Motor Full Load Current</i> <i>Start Mode</i> <i>Adaptive Start Profile</i> <i>Start Ramp Time</i> <i>Excess Start Time</i> <i>Locked Rotor Time</i>	Model dependent Adaptive Control Constant Acceleration 20 seconds 30 seconds 20 seconds
Compressor Screw	<i>Motor Full Load Current</i> <i>Start Mode</i> <i>Start Ramp Time</i> <i>Current Limit</i>	Model dependent Constant Current 5 seconds 400%
Compressor Recip	<i>Motor Full Load Current</i> <i>Start Mode</i> <i>Start Ramp Time</i> <i>Current Limit</i>	Model dependent Constant Current 5 seconds 450%
Conveyor	<i>Motor Full Load Current</i> <i>Start Mode</i> <i>Start Ramp Time</i> <i>Current Limit</i> <i>Stop Mode</i> <i>Adaptive Stop Profile</i> <i>Stop Time</i>	Model dependent Constant Current 5 seconds 400% Adaptive Control Constant Deceleration 10 seconds
Crusher Rotary	<i>Motor Full Load Current</i> <i>Start Mode</i> <i>Start Ramp Time</i> <i>Current Limit</i> <i>Excess Start Time</i> <i>Locked Rotor Time</i>	Model dependent Constant Current 10 seconds 400% 30 seconds 20 seconds
Crusher Jaw	<i>Motor Full Load Current</i> <i>Start Mode</i> <i>Start Ramp Time</i> <i>Current Limit</i> <i>Excess Start Time</i> <i>Locked Rotor Time</i>	Model dependent Constant Current 10 seconds 450% 40 seconds 30 seconds

7.2 Standard Menu

The standard menu provides access to commonly used parameters, allowing the user to configure the ASAB as required for the application.

	Default Setting
1 Motor Details	
1A <i>Motor Full Load Current</i>	Model dependent
2 Primary Start/Stop	
2A <i>Start Mode</i>	Constant Current
2B <i>Current Limit</i>	350%
2C <i>Initial Current</i>	350%
2D <i>Start Ramp Time</i>	00:10 mm:ss
2G <i>Excess Start Time</i>	00:20 mm:ss
2H <i>Stop Mode</i>	Coast To Stop
2I <i>Stop Time</i>	00:00 mm:ss
4 Protection Levels	
4B <i>Phase Sequence</i>	Any Sequence
4C <i>Undercurrent</i>	20% FLC
4D <i>Instantaneous Overcurrent</i>	400% FLC
4E <i>Input A Trip</i>	Always Active
5 Protection Delays	
5C <i>Undercurrent Delay</i>	00:05 mm:ss
5D <i>Instantaneous Overcurrent Delay</i>	00:00 mm:ss
5E <i>Input A Trip Delay</i>	00:00 mm:ss
5F <i>Input A Initial Delay</i>	00:00 mm:ss
6 Inputs	
6D <i>Input A Function</i>	Motor Set Select
6E <i>Input A Name</i>	Input Trip
7 Relay Outputs	
7A <i>Relay A Function</i>	Main Contactor
7B <i>Relay A On Delay</i>	00:00 mm:ss
7C <i>Relay A Off Delay</i>	00:00 mm:ss
7D <i>Relay B Function</i>	Run
7E <i>Relay B On Delay</i>	00:00 mm:ss
7F <i>Relay B Off Delay</i>	00:00 mm:ss
7G <i>Relay C Function</i>	Trip
7H <i>Relay C On Delay</i>	00:00 mm:ss
7I <i>Relay C Off Delay</i>	00:00 mm:ss
7J <i>Low Current Flag</i>	50% FLC
7K <i>High Current Flag</i>	100% FLC
7L <i>Motor Temperature Flag</i>	80% FLC
10 Display	
10A <i>Language</i>	English
10B <i>User Screen - Top Left</i>	Starter State
10C <i>User Screen - Top Right</i>	Blank
10D <i>User Screen - Bottom Left</i>	Hours Run
10E <i>User Screen - Bottom Right</i>	Blank
10J <i>Display A or kW</i>	Current

7.3 Extended Menu

The Extended Menu provides access to all the ASAB's programmable parameters.

		Default Setting
1	Motor Details	
	1A <i>Motor Full Load Current</i>	Model dependent
	1B <i>Locked Rotor Time</i>	00:10 mm:ss
	1C <i>Motor FLC-2</i>	Model dependent
	1D <i>Locked Rotor Time-2</i>	00:10 mm:ss
	1E <i>Dual Thermal Model</i>	Single
2	Primary Start/Stop	
	2A <i>Start Mode</i>	Constant Current
	2B <i>Current Limit</i>	350% FLC
	2C <i>Initial Current</i>	350% FLC
	2D <i>Start Ramp Time</i>	00:10 mm:ss
	2E <i>Kickstart Level</i>	500% FLC
	2F <i>Kickstart Time</i>	0 ms
	2G <i>Excess Start Time</i>	00:20 mm:ss
	2H <i>Stop Mode</i>	Coast To Stop
	2I <i>Stop Time</i>	00:00 mm:ss
	2J <i>Adaptive Start Profile</i>	Constant Acceleration
	2K <i>Adaptive Stop Profile</i>	Constant Deceleration
	2L <i>Adaptive Control Gain</i>	75%
3	Secondary Start/Stop	
	3A <i>Start Mode-2</i>	Constant Current
	3B <i>Current Limit-2</i>	350% FLC
	3C <i>Initial Current-2</i>	350% FLC
	3D <i>Start Ramp-2</i>	00:10 mm:ss
	3E <i>Kickstart Level-2</i>	500% FLC
	3F <i>Kickstart Time-2</i>	0 ms
	3G <i>Excess Start Time-2</i>	00:20 mm:ss
	3H <i>Stop Mode-2</i>	Coast To Stop
	3I <i>Stop Time-2</i>	00:00 mm:ss
	3J <i>Adaptive Start Profile-2</i>	Constant Acceleration
	3K <i>Adaptive Stop Profile-2</i>	Constant Deceleration
	3L <i>Adaptive Control Gain-2</i>	75%
4	Protection Levels	
	4A <i>Current Imbalance</i>	30%
	4B <i>Phase Sequence</i>	Any Sequence
	4C <i>Undercurrent</i>	20% FLC
	4D <i>Instantaneous Overcurrent</i>	400% FLC
	4E <i>Input A Trip</i>	Always Active
	4F <i>Motor Temperature Check</i>	Do Not Check
	4G <i>Frequency Check</i>	Start/Run
	4H <i>Frequency Variation</i>	±5 Hz
5	Protection Delays	
	5A <i>Restart Delay</i>	00:10 mm:ss
	5B <i>Current Imbalance Delay</i>	00:03 mm:ss
	5C <i>Undercurrent Delay</i>	00:05 mm:ss
	5D <i>Instantaneous Overcurrent Delay</i>	00:00 mm:ss
	5E <i>Input A Trip Delay</i>	00:00 mm:ss
	5F <i>Input A Initial Delay</i>	00:00 mm:ss
	5G <i>Frequency Delay</i>	00:01 mm:ss
6	Inputs	
	6A <i>Local/Remote</i>	LCL/RMT Anytime
	6B <i>Comms in Remote</i>	Enable Control in RMT
	6C <i>Remote Reset Logic</i>	Normally Closed (N/C)
	6D <i>Input A Function</i>	Motor Set Select
	6E <i>Input A Name</i>	Input Trip

7	Relay Outputs	
	7A <i>Relay A Function</i>	Main Contactor
	7B <i>Relay A On Delay</i>	00:00 mm:ss
	7C <i>Relay A Off Delay</i>	00:00 mm:ss
	7D <i>Relay B Function</i>	Run
	7E <i>Relay B On Delay</i>	00:00 mm:ss
	7F <i>Relay B Off Delay</i>	00:00 mm:ss
	7G <i>Relay C Function</i>	Trip
	7H <i>Relay C On Delay</i>	00:00 mm:ss
	7I <i>Relay C Off Delay</i>	00:00 mm:ss
	7J <i>Low Current Flag</i>	50% FLC
	7K <i>High Current Flag</i>	100% FLC
	7L <i>Motor Temperature Flag</i>	80%
8	Analog Output	
	8A <i>Analog Output A</i>	Current (% FLC)
	8B <i>Analog A Scale</i>	4-20 mA
	8C <i>Analog A Maximum Adjustment</i>	100%
	8D <i>Analog A Minimum Adjustment</i>	0%
9	Auto-Reset	
	9A <i>Auto-Reset Action</i>	Do Not Auto-Reset
	9B <i>Maximum Resets</i>	1
	9C <i>Reset Delay Groups A&B</i>	00:05 mm:ss
	9D <i>Reset Delay Group C</i>	5 minutes
10	Display	
	10A <i>Language</i>	English
	10B <i>User Screen - Top Left</i>	Starter State
	10C <i>User Screen - Top Right</i>	Blank
	10D <i>User Screen - Bottom Left</i>	Hours Run
	10E <i>User Screen - Bottom Right</i>	Blank
	10F <i>Graph Timebase</i>	10 seconds
	10G <i>Graph Maximum Adjustment</i>	400%
	10H <i>Graph Minimum Adjustment</i>	0%
	10I <i>Mains Reference Voltage</i>	400 V
	10J <i>Display A or kW</i>	Current
15	Restricted	
	15A <i>Access Code</i>	0000
	15B <i>Adjustment Lock</i>	Read & Write
	15C <i>Emergency Run</i>	Disable
	15D <i>Current Calibration</i>	100%
	15E <i>Shorted SCR Action</i>	3-Phase Control Only
	15F <i>Jog Torque</i>	50%
	15G <i>Brake Torque</i>	20%
	15H <i>Brake Time</i>	00:01 mm:ss
	15I <i>Brake Torque-2</i>	20%
	15J <i>Brake Time-2</i>	00:01 mm:ss
16	Protection Action	
	16A <i>Motor Overload</i>	Trip Starter
	16B <i>Current Imbalance</i>	Trip Starter
	16C <i>Undercurrent</i>	Trip Starter
	16D <i>Instantaneous Overcurrent</i>	Trip Starter
	16E <i>Input A Trip</i>	Trip Starter
	16F <i>Frequency</i>	Trip Starter
	16G <i>Motor Thermistor</i>	Trip Starter
	16H <i>Excess Start Time</i>	Trip Starter
	16I <i>Starter Communication</i>	Trip Starter
	16J <i>Heatsink Overtemperature</i>	Trip Starter
	16K <i>Battery/Clock</i>	Trip Starter
	16L <i>Network Communication</i>	Trip Starter
	16M <i>Low Control Volts</i>	Trip Starter

7.4 Parameter Descriptions

7.4.1 1 Motor Details



NOTE

Parameter 1B determines the trip current for motor overload protection. The default setting of parameter 1B provides Motor Overload Protection: Class 10, Trip Current 105% of FLA (full load amperage) or equivalent.

1A – Motor FLC

Range: Model dependent

Description: Matches the starter to the connected motor's full load current. Set to the full load current (FLC) rating shown on the motor nameplate.

1B – Locked Rotor Time

Range: 0:01 - 2:00 (minutes:seconds)

Default: 10 seconds

Description: Sets the maximum length of time the motor can sustain locked rotor current from cold before reaching its maximum temperature. Set according to the motor datasheet.

1C – Motor FLC-2

Range: Model dependent

Description: Sets the secondary motor's full load current.

1D – Locked Rotor Time-2

Range: 0:01 - 2:00 (minutes:seconds)

Default: 10 seconds

Description: Sets the maximum length of time the motor can sustain locked rotor current from cold before reaching its maximum temperature. Set according to the motor datasheet.

1E – Dual Thermal Model

Options: Single (default)
Dual

Description: Activates dual thermal modelling. The dual thermal model is required only if the ASAB is controlling two physically separate motors.



NOTE

The second thermal model is only active if parameter 1E *Dual Thermal Model* is set to 'Dual' and the starter is using the secondary motor set (a programmable input is set to 'Motor Set Select' and the input is active).

7.4.2 2 Primary Start/Stop

2A – Start Mode

Options: Constant Current (default)
Adaptive Control

Description: Selects the soft start mode.

2B – Current Limit

Range: 100% - 600% FLC

Default: 350%

Description: Sets the current limit for constant current and current ramp soft starting, as a percentage of motor full load current.

2C – Initial Current

Range: 100% - 600% FLC

Default: 350%

Description: Sets the initial start current level for current ramp starting, as a percentage of motor full load current. Set so that the motor begins to accelerate immediately after a start is initiated. If current ramp starting is not required, set the initial current equal to the current limit.

2D – Start Ramp Time

Range: 1 - 180 (seconds)

Default: 10 seconds

Description: Sets the total start time for an Adaptive Control start or the ramp time for current ramp starting (from the initial current to the current limit).

2E – Kickstart Level

Range: 100% - 700% FLC **Default:** 500%

Description: Sets the level of the kickstart current.

2F – Kickstart Time

Range: 0 – 2000 milliseconds **Default:** 0000 milliseconds

Description: Sets the kickstart duration. A setting of 0 disables kickstart.



CAUTION

Kickstart subjects the mechanical equipment to increased torque levels. Ensure the motor, load and couplings can handle the additional torque before using this feature.

2G – Excess Start Time

Excess start time is the maximum time the ASAB will attempt to start the motor. If the motor does not transition to Run mode within the programmed limit, the starter will trip. Set for a period slightly longer than required for a normal healthy start. A setting of 0 disables excess start time protection.

Range: 0:00 - 4:00 (minutes:seconds) **Default:** 20 seconds

Description: Set as required.

2H – Stop Mode

Options: Coast To Stop (default)
TVR Soft Stop
Adaptive Control
Brake

Description: Selects the stop mode.

2I – Stop Time

Range: 0:00 - 4:00 (minutes:seconds) **Default:** 0 second

Description: Sets the time for soft stopping the motor using timed voltage ramp or Adaptive Control. If a main contactor is installed, the contactor must remain closed until the end of the stop time. Use a programmable output configured to Run to control the main contactor. Sets the total stopping time when using brake.

2J – Adaptive Start Profile

Options: Early Acceleration
Constant Acceleration (default)
Late Acceleration

Description: Selects which profile the ASAB will use for an Adaptive Control soft start.

2K – Adaptive Stop Profile

Options: Early Deceleration
Constant Deceleration (default)
Late Deceleration

Description: Selects which profile the ASAB will use for an Adaptive Control soft stop.

2L – Adaptive Control Gain

Range: 1% - 200% **Default:** 75%

Description: Adjusts the performance of Adaptive Control. This setting affects both starting and stopping control.



NOTE

We recommend leaving the gain setting at the default level unless performance is not satisfactory. If the motor accelerates or decelerates too quickly at the end of a start or stop, increase the gain setting by 5%~10%. If the motor speed fluctuates during starting or stopping, decrease the gain setting slightly.

7.4.3 3 Secondary Start/Stop

Refer to the Primary Start/Stop parameters for parameter details.

3A – Start Mode-2

Options: Constant Current (default)
Adaptive Control

Description: Selects the soft start mode.

3B – Current Limit-2

Range: 100% - 600% FLC **Default:** 350%

Description: Sets the current limit for constant current and current ramp soft starting, as a percentage of motor full load current.

3C – Initial Current-2

Range: 100% - 600% **Default:** 350%

Description: Sets the initial start current level for current ramp starting, as a percentage of motor full load current. Set so that the motor begins to accelerate immediately after a start is initiated.
If current ramp starting is not required, set the initial current equal to the current limit.

3D – Start Ramp Time-2

Range: 1 - 180 (seconds) **Default:** 10 seconds

Description: Sets the total start time for an Adaptive Control start or the ramp time for current ramp starting (from the initial current to the current limit).

3E – Kickstart Level-2

Range: 100% - 700% FLC **Default:** 500%

Description: Sets the level of the kickstart current.

3F – Kickstart Time-2

Range: 0 - 2000 (milliseconds) **Default:** 0000 milliseconds

Description: Sets the kickstart duration. A setting of 0 disables kickstart.

3G – Excess Start Time-2

Range: 0:00 - 4:00 (minutes:seconds) **Default:** 20 seconds

Description: Set as required.

3H – Stop Mode-2

Options: Coast To Stop (default)
TVR Soft Stop
Adaptive Control
Brake

Description: Selects the stop mode.

3I – Stop Time-2

Range: 0:00 - 4:00 (minutes:seconds) **Default:** 0 second

Description: Sets the stop time.

3J – Adaptive Start Profile-2

Options: Early Acceleration
Constant Acceleration (default)
Late Acceleration

Description: Selects which profile the ASAB will use for an Adaptive Control soft start.

3K – Adaptive Stop Profile-2

Options: Early Deceleration
Constant Deceleration (default)
Late Deceleration

Description: Selects which profile the ASAB will use for an Adaptive Control soft stop.

3L – Adaptive Control Gain-2

Range: 1% - 200% **Default:** 75%

Description: Adjusts the performance of Adaptive Control. This setting affects both starting and stopping control.

7.4.4

4 Protection Levels

4A – Current Imbalance

Range: 10% - 50% **Default:** 30%

Description: Sets the trip point for current imbalance protection.

4B – Phase Sequence

Options: Any Sequence (default)
Positive Only
Negative Only

Description: Selects which phase sequences the soft starter will allow at a start. During its pre-start checks, the starter examines the sequence of the phases at its input terminals and trips if the actual sequence does not match the selected option.

4C – Undercurrent

Range: 0% - 100% **Default:** 20%

Description: Sets the trip point for undercurrent protection, as a percentage of motor full load current. Set to a level between the motor's normal working range and the motor's magnetising (no load) current (typically 25% to 35% of full load current). A setting of 0% disables undercurrent protection.

4D – Instantaneous Overcurrent

Range: 80% - 600% FLC **Default:** 400%

Description: Sets the trip point for instantaneous overcurrent protection, as a percentage of motor full load current.

4E – Input A Trip

Options: Always Active (default) A trip can occur at any time when the soft starter is receiving power.
Operating Only A trip can occur while the soft starter is running, stopping or starting.
Run Only A trip can only occur while the soft starter is running.

Description: Selects when an input trip can occur.

4F – Motor Temperature Check

Options: Do Not Check (default)
Check

Description: Selects whether the ASAB will verify the motor has sufficient thermal capacity for a successful start. The soft starter compares the motor's calculated temperature with the temperature rise from the last motor start and only operates if the motor is cool enough to start successfully.

4G – Frequency Check

Options: Do Not Check
Start Only
Start/Run (default)
Run Only

Description: Determines when and if the starter will monitor for a frequency trip.

6C – Remote Reset Logic

Options:	Normally Closed (default) Normally Open
Description:	Selects whether the ASAB's remote reset input (terminals 58, 57) is normally open or normally closed.

6D – Input A Function

Options:	Motor Set Select (default)	The ASAB can be configured with two separate sets of motor data. To use the secondary motor data, parameter 6D must be set to 'Motor Set Select' and 53, 55 must be closed when a start command is given. The ASAB checks which motor data to use at a start, and will use that motor data for the entire start/stop cycle.
	Input Trip (N/O)	Input A can be used to trip the soft starter. When parameter 6D is set to Input Trip (N/O), a closed circuit across 53, 55 trips the soft starter.
	Input Trip (N/C)	When parameter 6D is set to Input Trip (N/C), an open circuit across 53, 55 trips the soft starter.
	Local/Remote Select	Input A can be used to select between local and remote control, instead of using the LOCAL/REMOTE button on the keypad. When the input is open, the starter is in local mode and can be controlled via the keypad. When the input is closed, the starter is in remote mode. The START and LOCAL/REMOTE buttons are disabled, and the soft starter will ignore any Local/Remote select command from the serial communications network. To use Input A to select between local and remote control, parameter 6A must be set to 'LCL/RMT Anytime' or 'LCL/RMT When Off'.
	Emergency Run	In emergency run the soft starter continues to run until stopped, ignoring all trips and warnings (refer to parameter 15C for details). Closing the circuit across 53, 55 activates emergency run.
	Starter Disable	Opening the circuit across 53, 55 activates emergency run and the ASAB stops the motor. The ASAB can be disabled via the control inputs. An open circuit across 53, 55 will disable the starter. The ASAB will not respond to start commands. If running, the soft starter will allow the motor to coast to stop, ignoring the soft stop mode set in parameter 2H.
	Jog Forward	Activates jog operation in a forward direction (will operate only in Remote mode).
	Jog Reverse	Activates jog operation in reverse direction (will operate only in Remote mode).
Description:	Selects the function of Input A.	

6E – Input A Name

Options:	Input Trip (default)	No Flow
	Low Pressure	Starter Disable
	High Pressure	Controller
	Pump Fault	PLC
	Low Level	Vibration Alarm
	High Level	
Description:	Selects a message for the keypad to display when Input A is active.	

7.4.7 7 Relay Outputs

7A – Relay A Function

Options:	Off	Relay A is not used.
	Main Contactor (default)	The relay closes when the ASAB receives a start command, and remains closed as long as the motor is receiving voltage.
	Run	The relay closes when the starter changes to run state.
	Trip	The relay closes when the starter trips (refer to parameter 16A to 16M).
	Warning	The relay closes when the starter issues a warning (refer to parameter 16A to 16M).
	Low Current Flag	The relay closes when the low current flag activates (refer to parameter 7J <i>Low Current Flag</i> , while the motor is running).
	High Current Flag	The relay closes when the high current flag activates (refer to parameter 7K <i>High Current Flag</i> , while the motor is running).
	Motor Temperature Flag	The relay closes when the motor temperature flag activates (refer to parameter 7L <i>Motor Temperature Flag</i>).
Description:	Selects the function of Relay A (normally open).	

7B, 7C – Relay A Delays

The ASAB can be configured to wait before opening or closing Relay A.

Parameter 7B Relay A On Delay

Range: 0:00 - 5:00 (minutes:seconds) **Default:** 0 second
Description: Sets the delay for closing Relay A.

Parameter 7C Relay A Off Delay

Range: 0:00 - 5:00 (minutes:seconds) **Default:** 0 second
Description: Sets the delay for re-opening Relay A.

7D~7I – Output Relays B & C

Parameters 7D~7I configure the operation of Relays B and C in the same way as parameters 7A~7C configure Relay A. Refer to Relay A for details.

Relay B is a changeover relay.

- 7D Relay B Function **Default:** Run
- 7E Relay B On Delay
- 7F Relay B Off Delay

Relay C is normally open.

- 7G Relay C Function **Default:** Trip
- 7H Relay C On Delay
- 7I Relay C Off Delay

7J, 7K – Low Current Flag and High Current Flag

The ASAB has low and high current flags to give early warning of abnormal operation. The current flags can be configured to indicate an abnormal current level during operation, between the normal operating level and the undercurrent or instantaneous overcurrent trip levels. The flags can signal the situation to external equipment via one of the programmable outputs. The flags clear when the current returns within the normal operating range by 10% of the programmed motor full load current.

Parameter 7J Low Current Flag

Range: 1% - 100% FLC **Default:** 50%
Description: Sets the level at which the low current flag operates, as a percentage of motor full load current.

Parameter 7K High Current Flag

Range: 50% - 600% FLC **Default:** 100%
Description: Sets the level at which the high current flag operates, as a percentage of motor full load current.

7L – Motor Temperature Flag

The ASAB has a motor temperature flag to give early warning of abnormal operation. The flag can indicate that the motor is operating above its normal operating temperature but lower than the overload limit. The flag can signal the situation to external equipment via one of the programmable outputs.

Range: 0% - 160% **Default:** 80%
Description: Sets the level at which the motor temperature flag operates, as a percentage of the motor's thermal capacity.

7.4.8 8 Analog Output

The ASAB has an analog output, which can be connected to associated equipment to monitor motor performance.

8A – Analog Output A

Options:	Current (% FLC) (default)	Current as a percentage of motor full load current.
	Motor Temp (%)	Motor temperature as a percentage of the motor's thermal capacity.
	Motor kW (%)	Measured motor kilowatts, as a percentage of maximum kW.
	Motor kVA (%)	Measured motor kilovolt amperes, as a percentage of maximum kVA.
	Motor pf	Motor power factor, measured by the soft starter.

Measured motor kW:	$\sqrt{3} \times \text{average current} \times \text{mains reference voltage} \times \text{measured power factor}$
Maximum motor kW:	$\sqrt{3} \times \text{motor FLC} \times \text{mains reference voltage}$. Power factor is assumed to be 1
Measured motor kVA:	$\sqrt{3} \times \text{average current} \times \text{mains reference voltage}$
Maximum motor kVA:	$\sqrt{3} \times \text{motor FLC} \times \text{mains reference voltage}$

Description: Selects which information will be reported via the analog output.

8B – Analog A Scale

Range: 0-20 mA
4-20 mA (default)

Description: Selects the range of the analog output.

8C – Analog A Maximum

Range: 0% - 600% **Default:** 100%

Description: Calibrates the upper limit of the analog output to match the signal measured on an external current measuring device.

8D – Analog A Minimum

Range: 0% - 600% **Default:** 0%

Description: Calibrates the lower limit of the analog output to match the signal measured on an external current measuring device.

7.4.9 9 Auto-Reset

The ASAB can be programmed to automatically reset certain trips, which can help minimise operating downtime. Trips are divided into three categories for auto-reset, depending on the risk to the soft starter:

Group	
A	Current imbalance
	Phase Loss
	Power loss / Power circuit
	Frequency
B	Undercurrent
	Instantaneous overcurrent
	Input A Trip
C	Motor overload (thermal model)
	Motor thermistor
	Heatsink Overtemperature

Other trips cannot be automatically reset.

This function is ideal for remote installations using 2-wire control in Remote mode. If the 2-wire start signal is present after an auto-reset, the ASAB will restart.

9A – Auto-Reset Action

Options: Do Not Auto-Reset (default)
Reset Group A
Reset Group A & B
Reset Group A, B & C

Description: Selects which trips can be auto-reset.

9B – Maximum Resets

Range: 1 - 5 **Default:** 1

Description: Sets how many times the soft starter will auto-reset, if it continues to trip. The reset counter increases by one each time the soft starter auto-resets, and decreases by one after each successful start/stop cycle.



NOTE
If the starter is manually reset, the resets counter will return to zero.

9C – Reset Delay Groups A&B

Range: 00:05 - 15:00 (minutes:seconds) **Default:** 5 seconds

Description: Sets the delay before resetting Group A and Group B trips.

9D – Reset Delay Group C

Range: 5 - 60 (minutes) **Default:** 5 minutes

Description: Sets the delay before resetting Group C trips.

7.4.10 10 Display

10A – Language

Options:	English (default) Chinese Español Deutsch	Português Français Italiano Russian
Description:	Selects which language the keypad will use to display messages and feedback.	

10B, 10C, 10D, 10E – User-Programmable Screen

Options:	Blank	Displays no data in the selected area, allowing long messages to be shown without overlapping.
	Starter State	The starter's operating state (starting, running, stopping or tripped). Only available for top left and bottom left positions on the screen.
	Motor Current	The average current measured on three phases.
	Motor pf	The motor's power factor, measured by the soft starter.
	Mains Frequency	The average frequency measured on three phases.
	Motor kW	The motor's running power in kilowatts.
	Motor HP	The motor's running power in horsepower.
	Motor Temp	The motor's temperature, calculated by the thermal model.
	kWh	The number of kilowatt hours the motor has run via the soft starter.
	Hours Run	The number of hours the motor has run via the soft starter.
Description:	Selects which information will be displayed on the programmable monitoring screen.	
	<ul style="list-style-type: none"> • 10B User Screen - Top Left • 10C User Screen - Top Right • 10D User Screen - Bottom Left • 10E User Screen - Bottom Right 	Default: Starter State Default: Blank Default: Hours Run Default: Blank

10F – Graph Timebase

Options:	10 seconds (default) 30 seconds 1 minute 5 minutes 10 minutes 30 minutes 1 hour
Description:	Sets the graph time scale. The graph will progressively replace the old data with new data.

10G – Graph Maximum

Range:	0% – 600%	Default:	400%
Description:	Adjusts the upper limit of the performance graph.		

10H – Graph Minimum

Range:	0% – 600%	Default:	0%
Description:	Adjusts the lower limit of the performance graph.		

10I – Mains Reference Voltage

Range:	100 – 690 V	Default:	400 V
Description:	Sets the nominal mains voltage for the keypad's monitoring functions. This is used to calculate motor kilowatts and kilovolt amperes (kVA) but does not affect the ASAB's motor control or protection.		

10J – Display A or kW

Options:	Current (default) Motor kW
Description:	Selects whether the ASAB will display current (amperes) or motor kilowatts on the main monitoring screen.

7.4.11 15 Restricted

15A – Access Code

Range: 0000 - 9999 **Default:** 0000
Description: Sets the access code to control access to restricted sections of the menus. Use the **EXIT** and **MENU/ENTER** buttons to select which digit to alter and use the ▲ and ▼ buttons to change the value.



NOTE
 In the event of a lost access code, contact your supplier for a master access code that allows you to re-program a new access code.

15B – Adjustment Lock

Options: Read & Write (default) Allows users to alter parameter values in the Programming Menu.
 Read Only Prevents users altering parameter values in the Programming Menu. Parameter values can still be viewed.

Description: Selects whether the keypad will allow parameters to be changed via the Programming Menu.

15C – Emergency Run

Options: Disable (default)
 Enable

Description: Selects whether the soft starter will permit emergency run operation. In emergency run, the soft starter will start (if not already running) and continue to operate until emergency run ends, ignoring stop commands and trips. Emergency run is controlled using a programmable input.



CAUTION
 Continued use of Emergency Run is not recommended. Emergency Run may compromise the starter life as all protections and trips are disabled.
 Using the starter in Emergency Run mode will void the product warranty.

15D – Current Calibration

Range: 85% - 115% **Default:** 100%
Description: Calibrates the soft starter's current monitoring circuits to match an external current metering device. Use the following formula to determine the necessary adjustment:

$$\text{Calibration (\%)} = \frac{\text{Current shown on ASAB display}}{\text{Current measured by external device}}$$

eg 102% = $\frac{66\text{A}}{65\text{A}}$



NOTE
 This adjustment affects all current-based functions and protections.

15E – Shorted SCR Action

Options: 3-Phase Control Only (default)
 PowerThrough

Description: Selects whether the soft starter will allow PowerThrough operation. For critical applications this allows the soft starter to control the motor with two-phase control, if the soft starter is damaged on one phase. PowerThrough only operates after the soft starter has tripped on "Lx-Tx Shorted" and has been reset.



CAUTION
 PowerThrough uses a two-phase soft start technology and additional care is required when sizing circuit breakers and protection. Contact your local supplier for assistance.



NOTE
 PowerThrough remains active until '3-Phase Control Only' is reselected.
 PowerThrough operation does not support Adaptive Control soft starting or soft stopping. In PowerThrough, the ASAB will automatically select constant current soft starting and timed voltage ramp soft stopping. If PowerThrough is enabled, parameters 2C and 2B must be set appropriately.
 PowerThrough can only operate with internally bypassed soft starters.



NOTE

PowerThrough is only available with in-line installations. If the starter is installed inside delta, PowerThrough will not operate.

The starter will trip on Lx-Tx Shorted on the first start attempt after control power is applied. PowerThrough will not operate if control power is cycled between starts.

15F – Jog Torque

The ASAB can jog the motor at a reduced speed, which allows precise positioning of belts and flywheels. Jog can be used for either forward or reverse operation.

Range: 20% - 100% **Default:** 50%
Description: Sets the current limit for jog operation.

15G – Brake Torque

Range: 20% - 100% **Default:** 20%
Description: Sets the amount of brake torque the ASAB will use to slow the motor.

15H – Brake Time

Range: 1 - 30 (seconds) **Default:** 1 second
Description: Sets the duration for DC injection during a braking stop.



NOTE

Parameter 15H is used in conjunction with parameter 2I. Refer to *Brake* for details.

15I – Brake Torque-2

Range: 20% - 100% **Default:** 20%
Description: Sets the amount of brake torque the ASAB will use to slow the motor.

15J – Brake Time-2

Range: 1 - 30 (seconds) **Default:** 1 second
Description: Sets the duration for DC injection during a braking stop.

7.4.12 **16 Protection Action**



CAUTION

Defeating the protection may compromise the starter and motor, and should only be done in the case of emergency.

16A~16M – Protection Action

Options: Trip Starter (default)
Warn and Log
Log Only

Description: Selects the soft starter's response to each protection.

- 16A *Motor Overload*
- 16B *Current Imbalance*
- 16C *Undercurrent*
- 16D *Instantaneous Overcurrent*
- 16E *Input A Trip*
- 16F *Frequency*
- 16G *Motor Thermistor*
- 16H *Excess Start Time*
- 16I *Starter Communication*
- 16J *Heatsink Overtemperature*
- 16K *Battery/Clock*
- 16L *Network Communication*
- 16M *Low Control Volts*

7.5 Adjustment Lock

You can lock the Programming Menu to prevent users from altering parameter settings. The adjustment lock can be turned on and off using parameter 15B.

To lock the programming menu:

1. Open the Programming Menu.
2. Open the Extended Menu.
3. Select 'Restricted'.
4. Enter the Access Code.
5. Select parameter 15B *Adjustment Lock*
6. Select and store 'Read Only'.

If a user attempts to change a parameter value when the adjustment lock is active, an error message is displayed:

```
ACCESS DENIED
ADJ LOCK IS ON
```

7.6 Access Code

Critical parameters (parameter group 15 and higher) are protected by a four-digit security access code, preventing unauthorised users from viewing or modifying parameter settings.

When a user attempts to enter a restricted parameter group, the keypad prompts for an access code. The access code is requested once for the programming session, and authorisation continues until the user closes the menu.

To enter the access code, use the **EXIT** and **MENU/ENTER** buttons to select a digit, and the **▲** and **▼** buttons to change the value. When all four digits match your access code, press **MENU/ENTER**. The keypad will display an acknowledgement message before continuing.

```
ENTER ACCESS CODE
0####
```

MENU/ENTER

```
ACCESS ALLOWED
SUPERVISOR
```

To change the access code, use parameter 15A.

The default access code is 0000.

7.7 Setup Tools

Setup Tools includes maintenance options to configure the ASAB's date and time, reset the thermal models or load a standard parameter set.

To access the Setup Tools, open the Programming Menu then select Setup Tools.

7.7.1 Set Date and Time

To set the date and time:

1. Open the Setup Tools.
2. Scroll to the date/time screen.
3. Press the **MENU/ENTER** button to enter edit mode.
4. Press the **MENU/ENTER** and **EXIT** buttons to select which part of the date or time to edit.
5. Use the **▲** and **▼** buttons to change the value.
6. To save changes, press the **MENU/ENTER** button. The ASAB will confirm the changes. To cancel changes, press the **EXIT** button.

7.7.2 Load/Save Settings

The Load/Save Settings menu requires an access code and allows users to:

- Load the ASAB's parameters with default values
- Reload previously saved parameter settings from an internal file
- Save the current parameter settings to an internal file

In addition to the factory default values file, the ASAB can store two user-defined parameter files. These files contain default values until a user file is saved.

To load or save parameter settings:

1. Open the Setup Tools.
2. Scroll to Load/Save Settings and press the **MENU/ENTER** button.
3. Scroll to the required function and press the **MENU/ENTER** button.
4. At the confirmation prompt, select YES to confirm or NO to cancel and then **MENU/ENTER** to load/save the selection.

```
LOAD/SAVE SETTINGS
LOAD DEFAULTS
LOAD USER SET 1
LOAD USER SET 2
```

```
LOAD DEFAULTS
NO
YES
```

When the action has been completed, the screen will briefly display a confirmation message, then return to the status screens.

7.7.3 Reset Thermal Models



NOTE

This function is protected by the security access code.

The ASAB's advanced thermal modelling software constantly monitors the motor's performance. This allows the ASAB to calculate the motor's temperature and ability to start successfully at any time. If the ASAB is configured for use on two motors, each motor's temperature is modelled separately.

The thermal model for the active motor can be reset if required.

1. Open the Setup Tools.
2. Scroll to Reset Thermal Models and press **MENU/ENTER**.
3. Use ▼ to select Reset and press **MENU/ENTER** to confirm.

```
RESET THERMAL MODELS
M1 X%
M2 X%
MENU/ENTER TO RESET
```

```
DO NOT RESET
RESET
```

4. When the thermal model has been reset, the screen will display a confirmation message then return to the previous screen.



CAUTION

Resetting the motor thermal model may compromise motor life and should only be done in the case of emergency.

8 Logs Menu

The Logs Menu provides information on events, trips and starter performance.

Press the **LOGS** button to open the Logs Menu.

To navigate through the Logs Menu:

- to open a log, press the **MENU/ENTER** button.
- to scroll through the entries in each log, press the **▲** and **▼** buttons.
- to view details of a log entry, press the **MENU/ENTER** button.
- to return to the previous level, press the **EXIT** button.
- to close the Logs Menu, press **LOGS**.

8.1 Trip Log

The Trip Log stores details of the eight most recent trips, including the date and time the trip happened. Trip 1 is the most recent and trip 8 is the oldest stored trip.

To open the Trip Log:

1. Open the Logs Menu.
2. Scroll to Trip Log and press **MENU/ENTER**.
3. Use the **▲** and **▼** buttons to select a trip to view, and press **MENU/ENTER** to display details.

To close the log and return to the main display, press **LOGS**.

8.2 Event Log

The Event Log stores time-stamped details of the starter's 99 most recent events (actions, warnings and trips), including the date and time of the event. Event 1 is the most recent and event 99 is the oldest stored event.

To open the Event Log:

1. Open the Logs Menu.
2. Scroll to Event Log and press **MENU/ENTER**.
3. Use the **▲** and **▼** buttons to select an event to view, and press **MENU/ENTER** to display details.

To close the log and return to the main display, press **LOGS**.

8.3 Performance Counters

The performance counters store statistics on the starter's operation:

- Hours run (lifetime and since counter last reset)
- Number of starts (lifetime and since counter last reset)
- Motor kWh (lifetime and since counter last reset)
- Number of times the thermal model has been reset

To view the counters:

1. Open the Logs Menu.
2. Scroll to counters and press **MENU/ENTER**.
3. Use the **▲** and **▼** buttons to scroll through the counters. Press **MENU/ENTER** to view details.
4. To reset a counter, press **MENU/ENTER** then use the **▲** and **▼** buttons to select Reset/Do Not Reset. Press **MENU/ENTER** to confirm the action.

To close the counter and return to the Logs Menu, press **MENU/ENTER**.



NOTE

The reset counters function is protected by the access code.

9 Application Examples

A selection of Application Notes are available describing advanced installation or configuration of the ASAB for situations with specific performance requirements. Application notes are available for situations including brake and jog operation, pumping and advanced protection options.

9.1 Installation with Main Contactor

The ASAB is installed with a main contactor (AC3 rated). Control voltage must be supplied from the input side of the contactor.

The main contactor is controlled by the ASAB Main Contactor output, which by default is assigned to Output Relay A (terminals 13, 14).

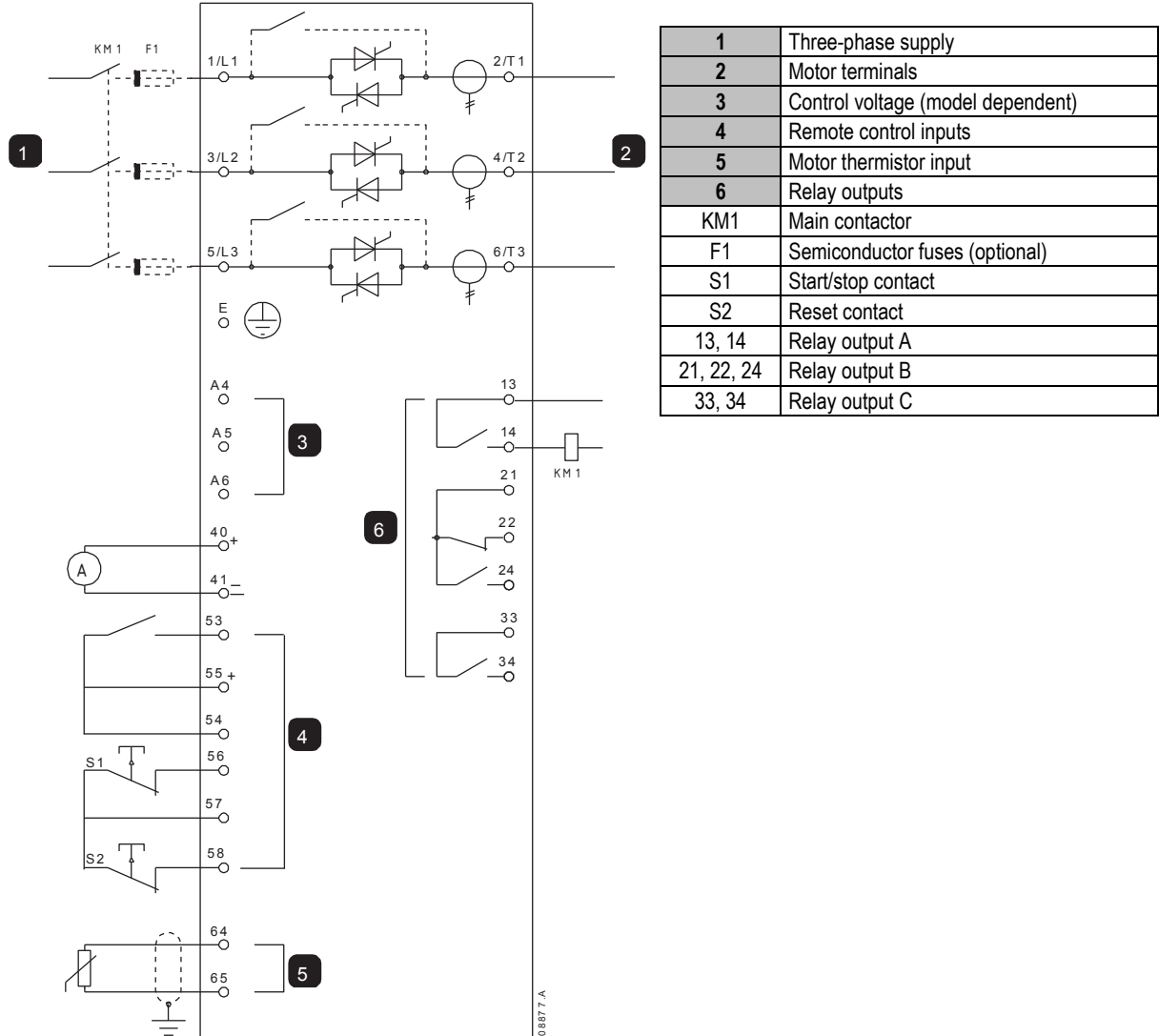

Parameter settings:

- Parameter *7A Relay A Function*
 - Select 'Main Contactor' - assigns the Main Contactor function to Relay Output A (default setting)

9.2 Installation with Bypass Contactor

The ASAB is installed with a bypass contactor (AC1 rated). The bypass contactor is controlled by the ASAB Run Output which by default is assigned to Output Relay B (terminals 21, 22, 24).

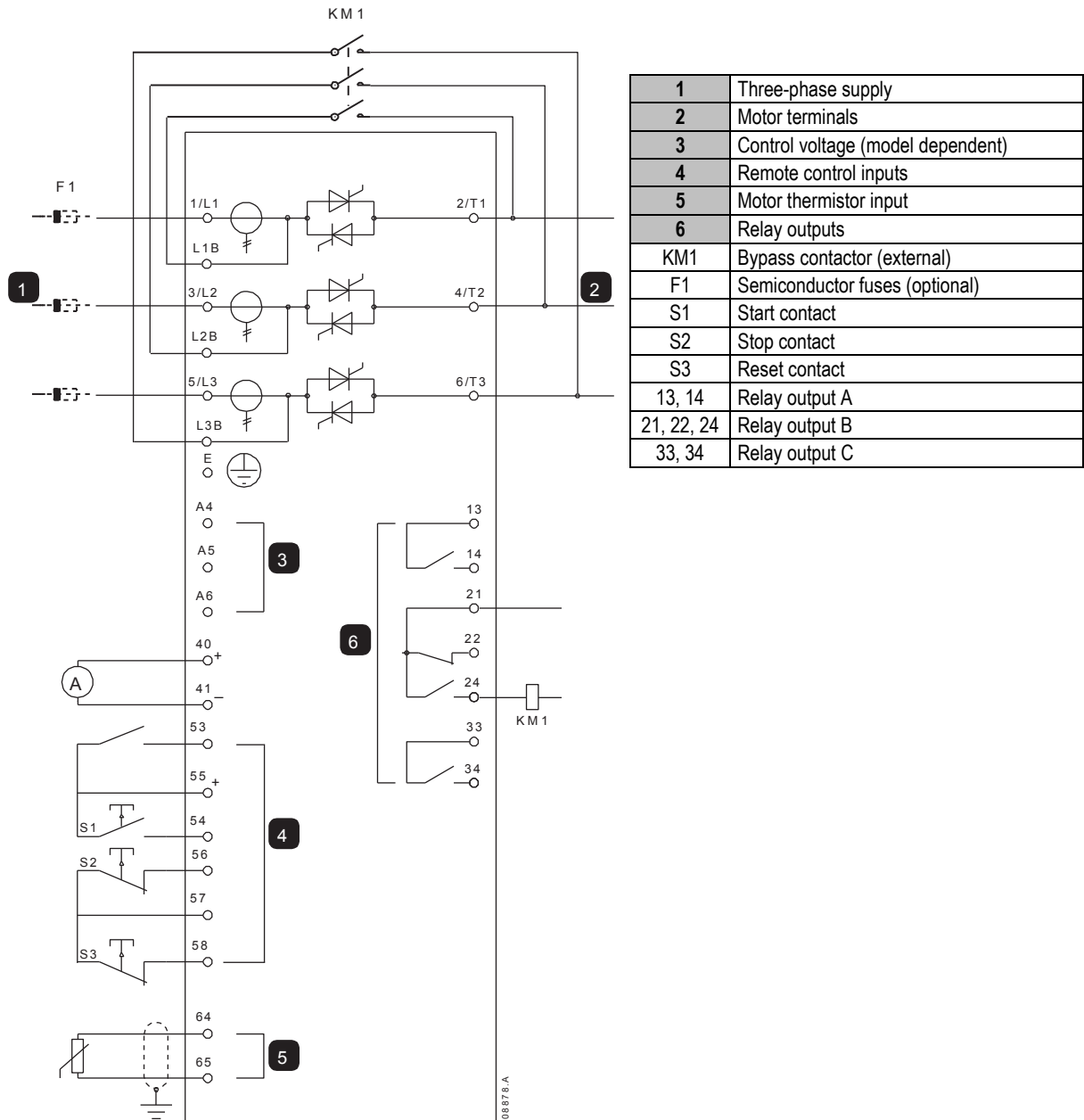

Parameter settings:

- Parameter 7D *Relay B Function*
 - Select 'Run' - assigns the run output function to Relay Output B (default value).

9.3 Emergency Run Operation

In normal operation the ASAB is controlled via a remote two-wire signal (terminals 56, 57).

Emergency Run is controlled by a two-wire circuit connected to Input A (terminals 53, 55). Closing Input A causes the ASAB to run the motor and ignore certain trip conditions.

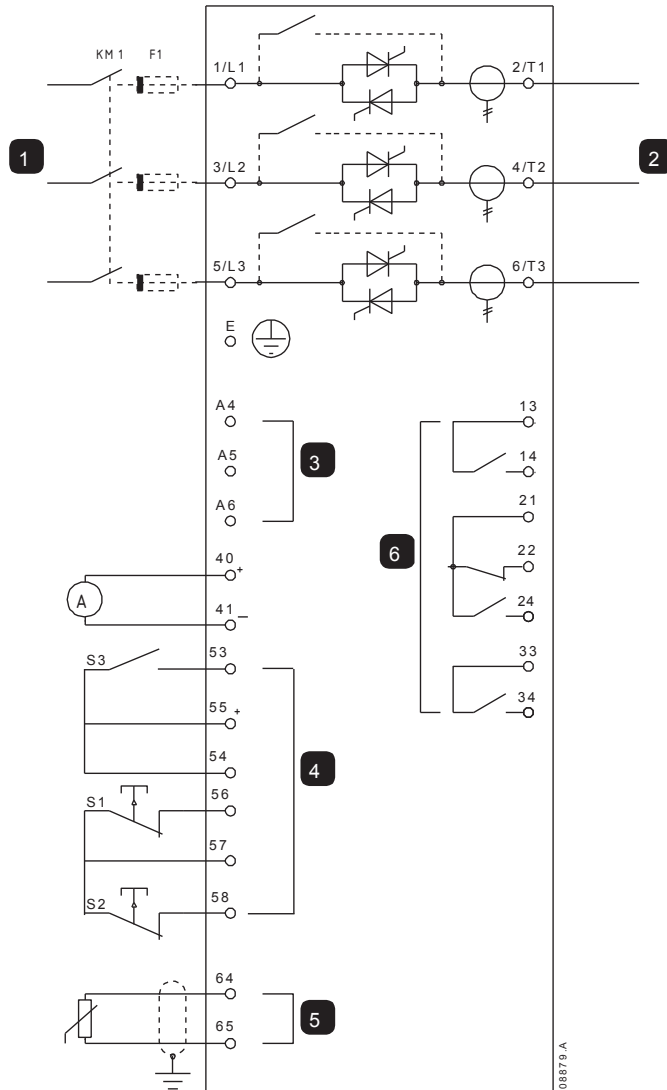

1	Three-phase supply
2	Motor terminals
3	Control voltage (model dependent)
4	Remote control inputs
5	Motor thermistor input
6	Relay outputs
S1	Start/stop contact
S2	Reset contact
S3	Emergency Run Contact
13, 14	Relay output A
21, 22, 24	Relay output B
33, 34	Relay output C

Parameter settings:

- Parameter 6D *Input A Function*
 - Select 'Emergency Run' - assigns Input A for Emergency Run function.
- Parameter 15C *Emergency Run*
 - Select 'Enable' - Enables Emergency Run mode.



NOTE

Although the Emergency Run satisfies the functionality requirements of Fire Mode, Santerno does not recommend its use in situations that require testing and/or compliance with specific standards as it is not certified.

9.4 Auxiliary Trip Circuit

In normal operation the ASAB is controlled via a remote two-wire signal (terminals 56, 57).

Input A (terminals 53, 55) is connected to an external trip circuit (such as a low pressure alarm switch for a pumping system). When the external circuit activates, the soft starter trips, which stops the motor.

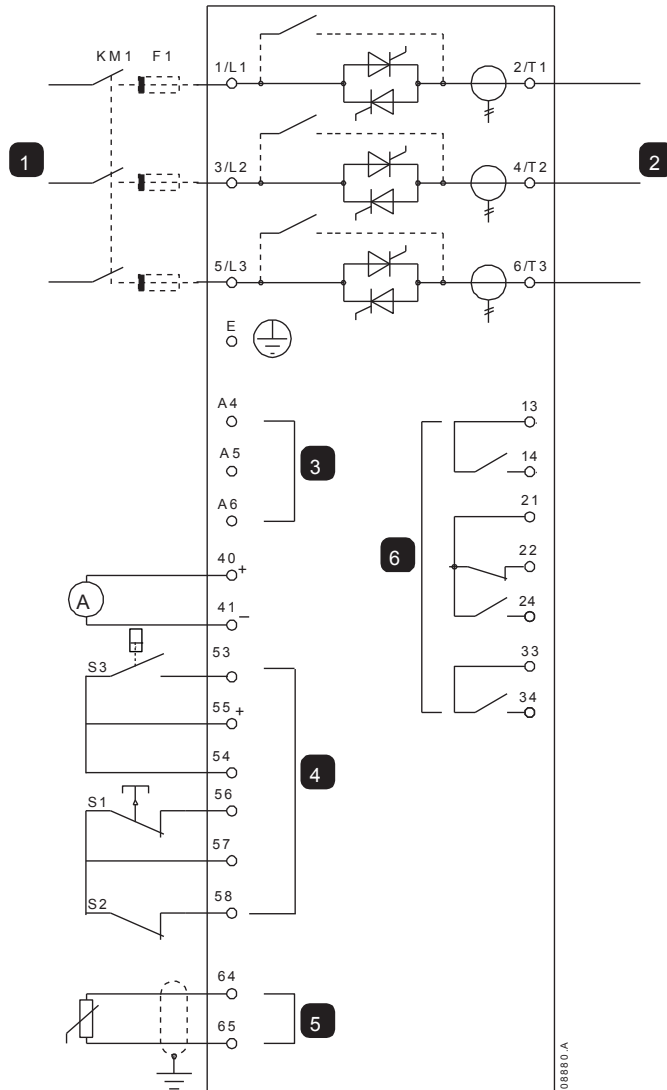

1	Three-phase supply
2	Motor terminals
3	Control voltage (model dependent)
4	Remote control inputs
5	Motor thermistor input
6	Relay outputs
S1	Start/stop contact
S2	Reset contact
S3	Auxiliary trip contact
13, 14	Relay output A
21, 22, 24	Relay output B
33, 34	Relay output C

Parameter settings:

- Parameter 6D *Input A Function*
 - Select 'Input Trip (N/O)'. Assigns the Input A to Auxiliary Trip (N/O) function.
- Parameter 6E *Input A Name*
 - Select a name, eg Low Pressure. Assigns a name to Input A.
- Parameter 4E *Input A Trip*
 - Set as required. For example, 'Run Only' limits the input trip to when the soft starter is running only.
- Parameter 5E *Input A Trip Delay*
 - Set as required. Sets a delay between the input activating and the soft starter tripping.
- Parameter 5F *Input A Initial Delay*
 - Set at around 120 seconds. Limits operation of the input trip to 120 seconds after the start signal. This allows time for pressure to build up in the piping before the low pressure input becomes active.

9.5 DC Brake with External Zero Speed Sensor

For loads which may vary between braking cycles, there are benefits in using an external zero-speed sensor to interface with the ASAB for brake shut-off. This control method ensures that the ASAB braking will always shut off when the motor has reached a standstill, thus avoiding unnecessary motor heating.

The following schematic diagram shows how you can use a zero-speed sensor with the ASAB to turn the brake function off at motor standstill. The zero-speed sensor (A2) is often referred to as an under-speed detector. Its internal contact is open at zero-speed and closed at any speed above zero-speed. Once the motor has reached a standstill, 53, 55 will open and the starter will be disabled. When the next start command is given (ie next application of KA1), 53, 55 closes and the ASAB is enabled.

The ASAB must be operated in remote mode and parameter 6D *Input A Function* must be set to 'Starter Disable'.

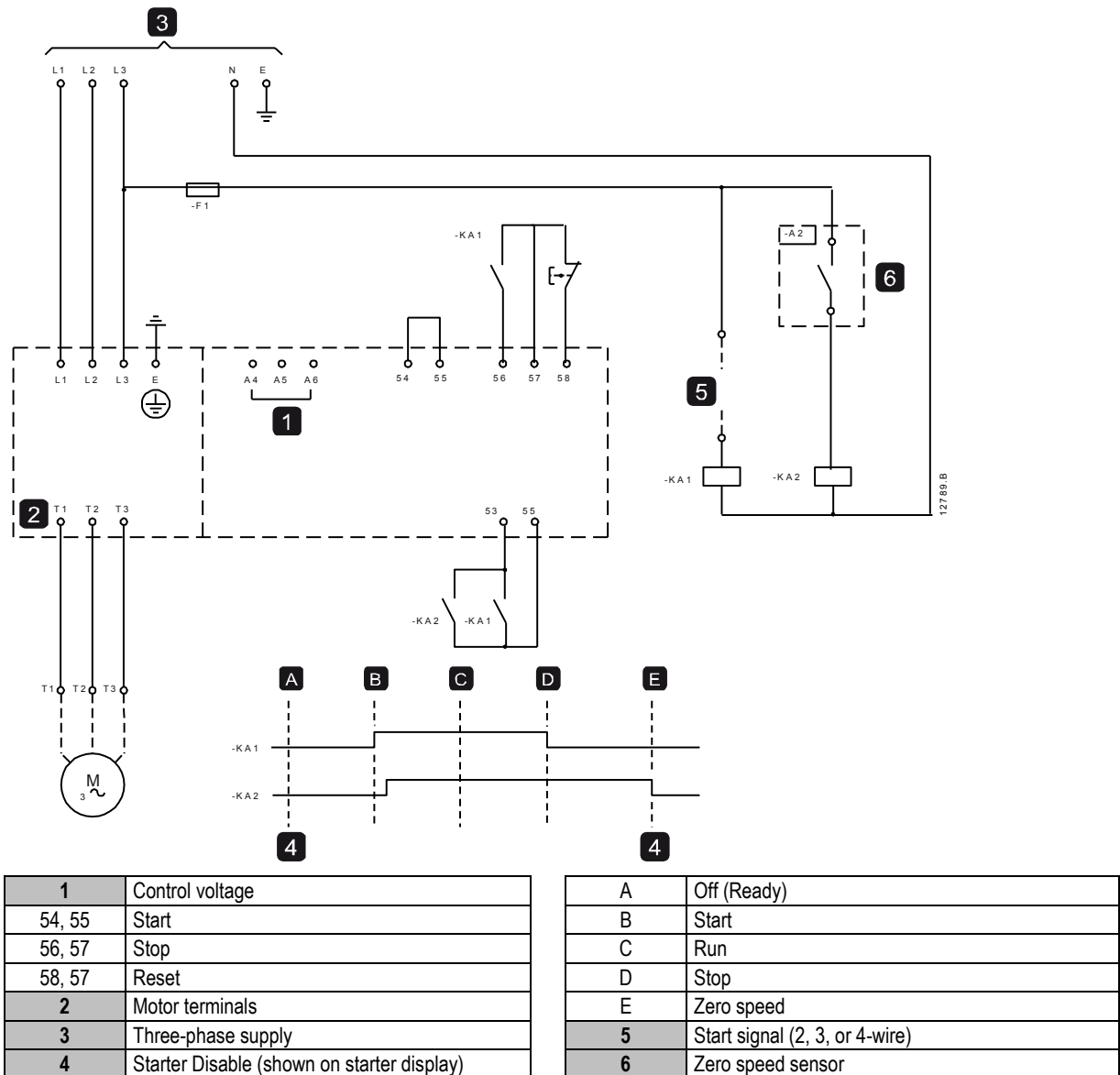

For details on configuring DC Brake, refer to *Brake* (page 30).



CAUTION

When using DC brake, the mains supply must be connected to the soft starter (input terminals L1, L2, L3) in positive phase sequence and parameter 4B *Phase Sequence* must be set to Positive Only.

9.6 Soft Braking

For applications with high inertia and/or a variable load, the ASAB can be configured for soft braking.

In this application the ASAB is employed with forward run and braking contactors. When the ASAB receives a start signal (pushbutton S1), it closes the forward run contactor (KM1) and controls the motor according to the programmed primary motor settings.

When the ASAB receives a stop signal (pushbutton S2), it opens the forward run contactor (KM1) and closes the braking contactor (KM2) after a delay of approximately 2-3 seconds (KT1). KA3 is also closed to activate the secondary motor settings, which should be user programmed for the desired stopping performance characteristics.

When motor speed approaches zero, the zero speed sensor (A2) stops the soft starter and opens the braking contactor (KM2).

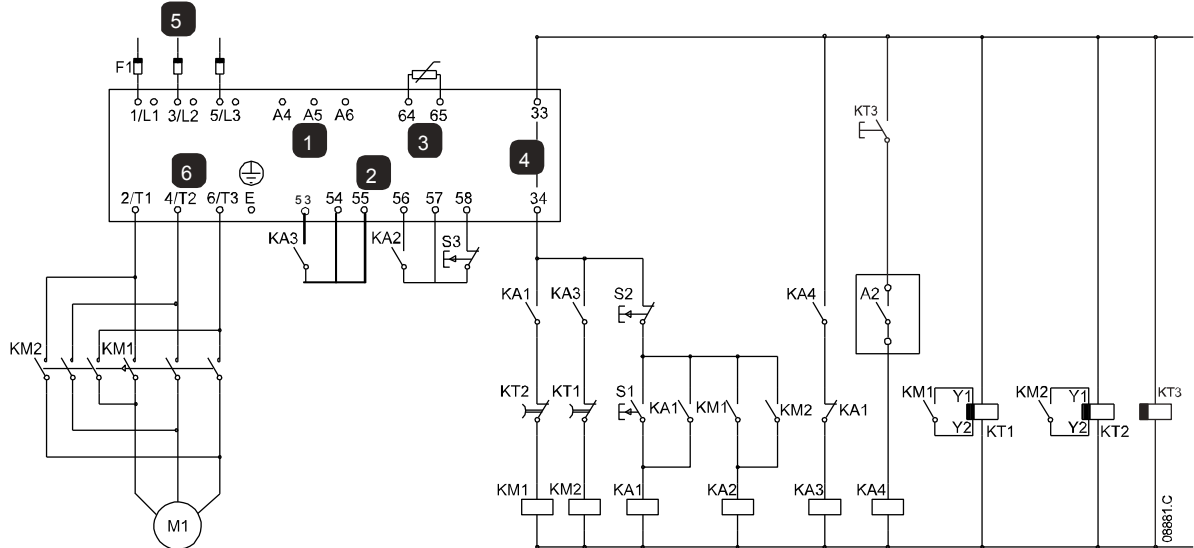

1	Control voltage (model dependent)
2	Remote control inputs
3	Motor thermistor input
4	Relay outputs
5	Three-phase supply
6	Motor terminals

A2	Zero speed sensor
KA1	Run relay
KA2	Start relay
KA3	Brake relay
KA4	Zero speed sensor relay
KM1	Line contactor (Run)
KM2	Line contactor (Brake)
KT1	Run delay timer
KT2	Brake delay timer
S1	Start contact
S2	Stop contact
S3	Reset contact

Parameter settings:

- Parameter 6D *Input A Function* (terminals 53, 55)
 - Select 'Motor Set Select' - assigns Input A for Motor set selection.
 - Set starting performance characteristics using the primary motor set.
 - Set braking performance characteristics using the secondary motor settings.
- Parameter 7G *Relay C Function*
 - Select 'Trip' - assigns Trip function to Relay Output C.



NOTE

If the ASAB trips on supply frequency (parameter 16F *Frequency*) when the braking contactor KM2 opens, modify the frequency protection settings.

9.7 Two Speed Motor

The ASAB can be configured for control of dual speed Dahlander type motors, using a high speed contactor (KM1), low speed contactor (KM2) and a star contactor (KM3).



NOTE

Pole Amplitude Modulated (PAM) motors alter the speed by effectively changing the stator frequency using external winding configuration. Soft starters are not suitable for use with this type of two-speed motor.

When the soft starter receives a high speed start signal, it closes the high speed contactor (KM1) and star contactor (KM3), then controls the motor according to the primary motor settings.

When the soft starter receives a low speed start signal, it closes the low speed contactor (KM2). This closes Input A and the ASAB controls the motor according to the secondary motor settings.

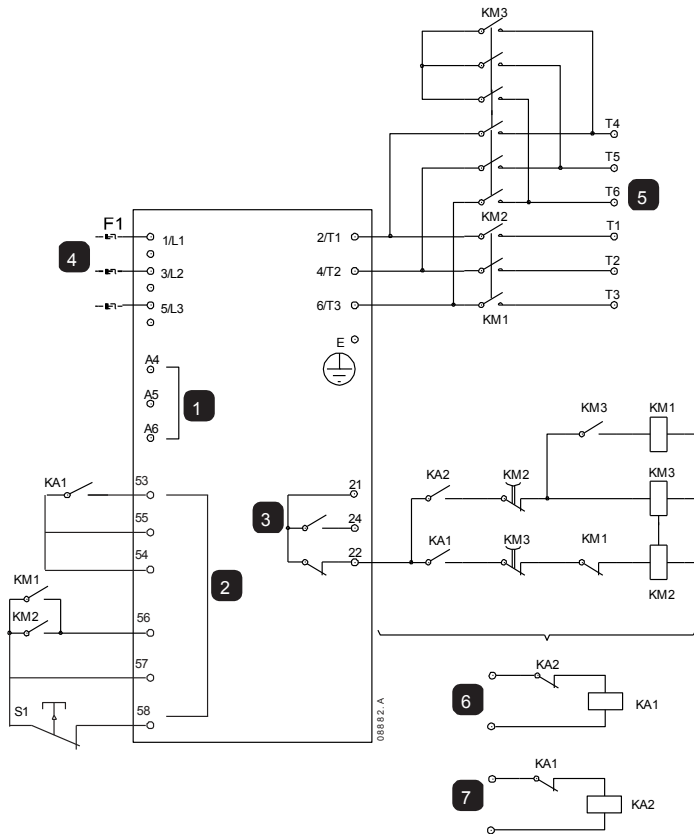

1	Control voltage (model dependent)
2	Remote control inputs
3	Relay outputs
4	Three-phase supply
5	Motor terminals
6	Remote low speed start input
7	Remote high speed start input

KA1	Remote start relay (low speed)
KA2	Remote start relay (high speed)
KM1	Line contactor (high speed)
KM2	Line contactor (low speed)
KM3	Star contactor (high speed)
S1	Reset contact
21, 22, 24	Relay output B



NOTE

Contactors KM2 and KM3 must be mechanically interlocked.

Parameter settings:

- Parameter 6D *Input A Function*
 - Select 'Motor Set Select' - assigns Input A for Motor set selection.
 - Set high speed performance characteristics using the primary motor settings.
 - Set low speed performance characteristics using the secondary motor settings.
- Parameter 7D *Relay B Function*
 - Select 'Trip' - assigns Trip function to Relay Output B



NOTE

If the ASAB trips on supply frequency (parameter 16F *Frequency*) when the high-speed start signal (7) is removed, modify the frequency protection settings.

10 Troubleshooting

10.1 Protection Responses

When a protection condition is detected, the ASAB will write this to the event log and may also trip or issue a warning. The soft starter's response depends on the Protection Action setting (parameter group 16).

Some protection responses cannot be adjusted by the user. These trips are usually caused by external events (such as phase loss) or by a fault within the soft starter. These trips do not have associated parameters and cannot be set to Warn or Log.



If the ASAB trips you will need to identify and clear the condition that triggered the trip, then reset the soft starter before restarting. To reset the starter, press the **RESET** button on the keypad or activate the Reset remote input.

If the ASAB has issued a warning, the soft starter will reset itself once the cause of the warning has been resolved.

10.2 Trip Messages

This table lists soft starter's protection mechanisms and the probable cause of the trip. Some of these can be adjusted using parameter group 4 Protection Levels and parameter group 16 Protection Action, other settings are built-in system protections and cannot be set or adjusted.



Display	Possible cause/Suggested solution
BATTERY/CLOCK	A verification error has occurred on the real time clock, or the backup battery voltage is low. If the battery is low and the power is off, date/time settings will be lost. Reprogram the date and time. Related parameters: 16K
CONTROLLER	This is a name selected for a programmable input. Refer to Input trip.
CURRENT IMBALANCE	Current imbalance can be caused by problems with the motor, the environment or the installation, such as: <ul style="list-style-type: none"> An imbalance in the incoming mains voltage A problem with the motor windings A light load on the motor A phase loss on input terminals L1, L2 or L3 during Run mode An SCR that has failed open circuit. A failed SCR can only be definitely diagnosed by replacing the SCR and checking the starter's performance. Related parameters: 4A, 5B, 16B
CURRENT READ ERR LX	Where 'X' is 1, 2 or 3. Internal fault (PCB fault). The output from the CT circuit is not close enough to zero when the SCRs are turned off. Contact your local supplier for advice. This trip is not adjustable. Related parameters: None
EXCESS START TIME	Excess start time trip can occur in the following conditions: <ul style="list-style-type: none"> parameter 1A <i>Motor Full Load Current</i> is not appropriate for the motor parameter 2B <i>Current Limit</i> has been set too low parameter 2D <i>Start Ramp Time</i> has been set greater than the setting for 2G <i>Excess Start Time</i> setting parameter 2D <i>Start Ramp Time</i> is set too short for a high inertia load when using Adaptive Control Related parameters: 1A, 1C, 2B, 2D, 2G, 3B, 3D, 3G, 16H
FIRING FAIL PX	Where 'X' is phase 1, 2 or 3. The SCR did not fire as expected. The SCR may be faulty or there may be an internal wiring fault. This trip is not adjustable. Related parameters: None
FLC TOO HIGH (FLC OUT OF RANGE)	The ASAB can support higher motor full load current values when connected to the motor using inside delta configuration rather than in-line connection. If the soft starter is connected in-line but the programmed setting for parameter 1A <i>Motor Full Load Current</i> is above the in-line maximum, the soft starter will trip at start (see <i>Minimum and Maximum Current Settings</i> on page 8). If the soft starter is connected to the motor using inside delta configuration, the soft starter may not be correctly detecting the connection. Contact your local supplier for advice. Related parameters: 1A, 1C
FREQUENCY (MAINS SUPPLY)	The mains frequency has gone beyond the specified range. Check for other equipment in the area that could be affecting the mains supply, particularly variable speed drives and switch mode power supplies (SMPS). If the ASAB is connected to a generator set supply, the generator may be too small or could have a speed regulation problem. Related parameters: 4G, 4H, 5G, 16F

HEATSINK OVERTEMPERATURE	<p>Check if cooling fans are operating. If mounted in an enclosure, check if ventilation is adequate. Fans operate during Start, Run and for 10 minutes after the starter exits the Stop state.</p> <p> NOTE Models ASAB-0023B to ASAB-0053B and ASAB-0170B do not have a cooling fan. Models with fans will operate the cooling fans from a Start until 10 minutes after a Stop.</p> <p>Related parameters: 16J</p>
HIGH LEVEL	This is a name selected for a programmable input. Refer to Input trip.
HIGH PRESSURE	This is a name selected for a programmable input. Refer to Input trip.
INPUT TRIP	<p>The soft starter's programmable input is set to a trip function and has activated. Resolve the trigger condition.</p> <p>Related parameters: 4E, 5E, 5F, 6D, 6E, 16E</p>
INSTANTANEOUS OVERCURRENT	<p>There has been a sharp rise in motor current, probably caused by a locked rotor condition (shearpin) while running. This may indicate a jammed load.</p> <p>Related parameters: 4D, 5D, 16D</p>
INTERNAL FAULT X	<p>The ASAB has tripped on an internal fault. Contact your local supplier with the fault code (X).</p> <p>Related parameters: None</p>
L1 PHASE LOSS L2 PHASE LOSS L3 PHASE LOSS	<p>During pre-start checks the starter has detected a phase loss as indicated.</p> <p>In run state, the starter has detected that the current on the affected phase has dropped below 3.3% of the programmed motor FLC for more than 1 second, indicating that either the incoming phase or connection to the motor has been lost.</p> <p>Check the supply and the input and output connections at the starter and at the motor end. Phase loss can also be caused by a failed SCR, particularly an SCR that has failed open circuit. A failed SCR can only be definitely diagnosed by replacing the SCR and checking the starter's performance.</p> <p>Related parameters: None</p>
L1-T1 SHORTED L2-T2 SHORTED L3-T3 SHORTED	<p>During pre-start checks the starter has detected a shorted SCR or a short within the bypass contactor as indicated. If the starter is connected in-line with the motor, consider using PowerThrough to allow operation until the starter can be repaired.</p> <p> NOTE PowerThrough is only available with in-line installations. If the starter is installed inside delta, PowerThrough will not operate.</p> <p>The starter will trip on Lx-Tx Shorted on the first start attempt after control power is applied. PowerThrough will not operate if control power is cycled between starts.</p> <p>Related parameters: 15E</p>
LOW CONTROL VOLTS	<p>The ASAB has detected a drop in the control voltage.</p> <ul style="list-style-type: none"> Check the external control supply (terminals A4, A5, A6) and reset the starter. <p>If the external control supply is stable:</p> <ul style="list-style-type: none"> the 24 V supply on the main control PCB may be faulty; or the bypass driver PCB may be faulty (internally bypassed models only). Contact your local supplier for advice. <p>This protection is not active in Ready state.</p> <p>Related parameters: 16M</p>
LOW LEVEL	This is a name selected for a programmable input. Refer to Input trip.
LOW PRESSURE	This is a name selected for a programmable input. Refer to Input trip.
MOTOR OVERLOAD (THERMAL MODEL) MOTOR 2 OVERLOAD	<p>The motor has reached its maximum thermal capacity. Overload can be caused by:</p> <ul style="list-style-type: none"> The soft starter protection settings not matching the motor thermal capacity Excessive starts per hour Excessive throughput Damage to the motor windings <p>Resolve the cause of the overload and allow the motor to cool.</p> <p>Related parameters: 1A, 1B, 1C, 1D, 2A, 2B, 3A, 3B, 16A</p>
MOTOR CONNECTION TX	<p>Where 'X' is 1, 2 or 3.</p> <p>The motor is not connected correctly to the soft starter for in-line or inside delta use.</p> <ul style="list-style-type: none"> Check individual motor connections to the soft starter for power circuit continuity. Check connections at the motor terminal box. <p>This trip is not adjustable.</p> <p>Related parameters: None</p>

MOTOR THERMISTOR	<p>The motor thermistor input has been enabled and:</p> <ul style="list-style-type: none"> The resistance at the thermistor input has exceeded 3.6 kΩ for more than one second. The motor winding has overheated. Identify the cause of the overheating and allow the motor to cool before restarting. The motor thermistor input has been opened. <p> NOTE If a valid motor thermistor is no longer used, a 1.2 kΩ resistor must be fitted across terminals 64, 65.</p> <p>Related parameters: 16G</p>
NETWORK COMMUNICATION (BETWEEN MODULE AND NETWORK)	<p>The network master has sent a trip command to the starter, or there may be a network communication problem.</p> <p>Check the network for causes of communication inactivity.</p> <p>Related parameters: 16L</p>
NO FLOW	<p>This is a name selected for a programmable input. Refer to Input trip.</p>
PARAMETER OUT OF RANGE	<ul style="list-style-type: none"> A parameter value is outside the valid range. <p>The starter will load the default value for all affected parameters. Press RESET to go to the first invalid parameter and adjust the setting.</p> <p>Related parameters: None</p>
PHASE SEQUENCE	<p>The phase sequence on the soft starter's input terminals (L1, L2, L3) is not valid.</p> <p>Check the phase sequence on L1, L2, L3 and ensure the setting in parameter 4B is suitable for the installation.</p> <p>Related parameters: 4B</p>
PLC	<p>This is a name selected for a programmable input. Refer to Input trip.</p>
POWER LOSS / POWER CIRCUIT	<p>The starter is not receiving mains supply on one or more phases when a Start Command is given.</p> <p>Check that the main contactor closes when a start command is given, and remains closed until the end of a soft stop. Check the fuses. If testing the soft starter with a small motor, it must draw at least 2% of its minimum FLC setting on each phase.</p> <p>Related parameters: None</p>
PUMP FAULT	<p>This is a name selected for a programmable input. Refer to Input trip.</p>
STARTER COMMUNICATION (BETWEEN MODULE AND SOFT STARTER)	<ul style="list-style-type: none"> There is a problem with the connection between the soft starter and the optional communications module. Remove and reinstall the module. If the problem persists, contact your local distributor. There is an internal communications error within the soft starter. Contact your local distributor. <p>Related parameters: 16I</p>
STARTER DISABLE	<p>This is a name selected for a programmable input. Refer to Input trip.</p>
THERMISTOR CIRCUIT	<p>The thermistor input has been enabled and:</p> <ul style="list-style-type: none"> The resistance at the input has fallen below 20 Ω (the cold resistance of most thermistors will be over this value) or A short circuit has occurred. Check and resolve this condition. <p>Related parameters: None</p> <p>Check that a PT100 (RTD) is not connected to 64, 65.</p> <p>Related parameters: None</p>
TIME-OVERCURRENT	<p>The ASAB is internally bypassed and has drawn high current during running. (The 10A protection curve trip has been reached or the motor current has risen to 600% of the motor FLC setting.)</p> <p>Related parameters: None</p>
UNDERCURRENT	<p>The motor has experienced a sharp drop in current, caused by loss of load. Causes can include broken components (shafts, belts or couplings), or a pump running dry.</p> <p>Related parameters: 4C, 5C, 16C</p>
UNSUPPORTED OPTION (FUNCTION NOT AVAILABLE IN INSIDE DELTA)	<p>The selected function is not available (eg jog is not supported in inside delta configuration).</p> <p>Related parameters: None</p>
VIBRATION ALARM	<p>This is a name selected for a programmable input. Refer to Input trip.</p>
U2C FAIL PX	<p>Where 'X' is 1, 2 or 3.</p> <p>Internal fault (PCB fault). Contact your local supplier for advice.</p> <p>This trip is not adjustable.</p> <p>Related parameters: None</p>

10.3 General Faults

This table describes situations where the soft starter does not operate as expected but does not trip or give a warning.

Symptom	Probable Cause
Starter "Not Ready"	<ul style="list-style-type: none"> Check Input A (53, 55). The starter disable function may be active. If parameter 6D is set to Starter Disable and there is an open circuit on 53, 55, the ASAB will not start.
The soft starter does not respond to the START or RESET button on the keypad.	<ul style="list-style-type: none"> The soft starter may be in Remote control mode. When the soft starter is in Remote control mode, the Local LED on the starter is off. Press the LOCAL/REMOTE button once to change to Local control.
The soft starter does not respond to commands from the control inputs.	<ul style="list-style-type: none"> The soft starter may be in Local control mode. When the soft starter is in Local control mode, the Local LED on the starter is on. Press the LOCAL/REMOTE button once to change to Remote control. The control wiring may be incorrect. Check that the remote start, stop and reset inputs are configured correctly (refer to <i>Control Wiring</i> on page 12 for details). The signals to the remote inputs may be incorrect. Test the signalling by activating each input signal in turn. The appropriate remote control input LED should activate on the starter.
The soft starter does not respond to a start command from either the local or remote controls.	<ul style="list-style-type: none"> The soft starter may be waiting for the restart delay to elapse. The length of the restart delay is controlled by parameter 5A <i>Restart Delay</i>. The motor may be too hot to permit a start. If parameter 4F <i>Motor Temperature Check</i> is set to Check, the soft starter will only permit a start when it calculates that the motor has sufficient thermal capacity to complete the start successfully. Wait for the motor to cool before attempting another start. The starter may be disabled via a programmable input. If parameter 6D is set to Starter Disable and there is an open circuit on 53, 55, the ASAB will not start. If there is no further need to disable the starter, close the circuit on the input. <p>NOTE  Parameter 6A <i>Local/Remote</i> controls when the LOCAL/REMOTE button is enabled.</p>
A reset does not occur after an Auto-Reset, when using a remote two-wire control.	<ul style="list-style-type: none"> The remote 2-wire start signal must be removed and reapplied for a re-start.
Non-resettable Thermistor Cct trip, when there is a link between the thermistor input 64, 65 or when the motor thermistor connected between 64, 65 is permanently removed.	<ul style="list-style-type: none"> The thermistor input is enabled once a link is fitted and short circuit protection has activated. <ul style="list-style-type: none"> Remove the link then load the default parameter set. This will disable the thermistor input and clear the trip. Place a 1k2 Ω resistor across the thermistor input. Turn thermistor protection to 'Log only' (parameter 16G).
The soft starter does not control the motor correctly during starting.	<ul style="list-style-type: none"> Start performance may be unstable when using a low Motor Full Load Current setting (parameter 1A). This can affect use on a small test motor with full load current between 5 A and 50 A. Power factor correction (PFC) capacitors must be installed on the supply side of the soft starter. To control a dedicated PFC capacitor contactor, connect the contactor to run relay terminals.
Motor does not reach full speed.	<ul style="list-style-type: none"> If the start current is too low, the motor will not produce enough torque to accelerate to full speed. The soft starter may trip on excess start time. <p>NOTE  Make sure the motor starting parameters are appropriate for the application and that you are using the intended motor starting profile. If parameter 6D is set to Motor Set Select, check that the corresponding input is in the expected state.</p> <p>The load may be jammed. Check the load for severe overloading or a locked rotor situation.</p>
Erratic motor operation.	<ul style="list-style-type: none"> The SCRs in the ASAB require at least 5 A of current to latch. If you are testing the soft starter on a motor with full load current less than 5 A, the SCRs may not latch correctly.
Erratic and noisy motor operation.	<ul style="list-style-type: none"> If the soft starter is connected to the motor using inside delta configuration, the soft starter may not be correctly detecting the connection. Contact your local supplier for advice.
Soft stop ends too quickly.	<ul style="list-style-type: none"> The soft stop settings may not be appropriate for the motor and load. Review the settings of parameters 2H, 2I, 3H and 3I. If the motor is very lightly loaded, soft stop will have limited effect.
Adaptive Control, brake, jog and PowerThrough functions not working.	<ul style="list-style-type: none"> These features are only available with in-line installation. If the ASAB is installed inside delta, these features will not operate.

<p>After selecting Adaptive Control the motor used an ordinary start and/or the second start was different to the first.</p>	<ul style="list-style-type: none"> The first Adaptive Control start is actually 'Constant Current' so that the starter can learn from the motor characteristics. Subsequent starts use Adaptive Control.
<p>PowerThrough does not operate when selected.</p>	<ul style="list-style-type: none"> The starter will trip on Lx-Tx Shorted on the first start attempt after control power is applied. PowerThrough will not operate if control power is cycled between starts.
<p>Parameter settings cannot be stored.</p>	<ul style="list-style-type: none"> Make sure you are saving the new value by pressing the MENU/ENTER button after adjusting a parameter setting. If you press EXIT, the change will not be saved. Check that the adjustment lock (parameter 15B) is set to <i>Read & Write</i>. If the adjustment lock is set to <i>Read Only</i>, settings can be viewed but not changed. You need to know the security access code to change the adjustment lock setting. The EEPROM may be faulty on the keypad. A faulty EEPROM will also trip the soft starter, and the keypad will display the message Parameter out of Range. Contact your local supplier for advice.
<p>Remote keypad shows message "awaiting data"</p>	<p>The keypad is not receiving data from the control PCB. Check the cable connection.</p>

11 Accessories

11.1 Communication Modules

ASAB soft starters support network communication via easy-to-install communications modules. Each soft starter can support one communications module at a time.

Available protocols:

Ethernet (Profinet, Modbus TCP, Ethernet IP), Profibus, DeviceNet, Modbus RTU, and USB.

11.2 Remote Control Panel (RCP)

A remote mounted keypad can be installed with the ASAB. The keypad can be mounted up to 3 metres away from the starter, for control and monitoring.

The starter can be controlled and programmed from either the remote keypad or the keypad on the starter. Both displays show the same information.

The remote keypad also allows parameter settings to be copied between soft starters.

11.3 Finger Guard Kit

Finger guards may be specified for personnel safety. Finger guards fit over the soft starter terminals to prevent accidental contact with live terminals. Finger guards provide IP20 protection when correctly installed.



NOTE

Finger guards can be used on soft starter models ASAB-0145B~ASAB-1000B (internally bypassed models only). Different kits are required for different models.

11.4 PC Software

WinMaster PC software provides monitoring, programming and control of up to 99 soft starters.

A Modbus or USB communication module is required for each starter to use WinMaster.

12 Busbar Adjustment Procedure

The busbars on non-bypassed models ASAB-0380C ~ ASAB-1600C can be adjusted for top or bottom input and output as required.



NOTE

Many electronic components are sensitive to static electricity. Voltages so low that they cannot be felt, seen or heard, can reduce the life, affect performance, or completely destroy sensitive electronic components. When performing service, proper ESD equipment should be used to prevent possible damage from occurring.

All units are manufactured with input and output busbars at the bottom of the unit as standard. The input and/or output busbars can be moved to the top of the unit if required.

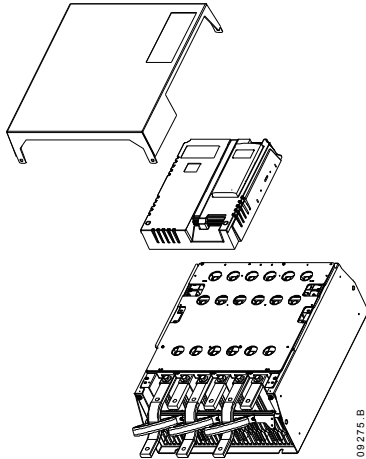

1. Remove all wiring and links from the soft starter before dismantling the unit.
2. Remove the unit cover (4 screws).
3. Remove the keypad faceplate, then gently remove the keypad (2 screws).
4. Remove the control terminal plugs.
5. Gently fold the main plastic away from the starter (12 screws).
6. Unplug the keypad loom from CON 1 (see note).
7. Label each SCR firing loom with the number of the corresponding terminal on the backplane PCB, then unplug the looms.
8. Unplug the thermistor, fan and current transformer wires from the model board.
9. Remove the plastic tray from the starter (four screws).



NOTE

Remove the main plastic slowly to avoid damaging the keypad wiring loom which runs between the main plastic and the backplane PCB.

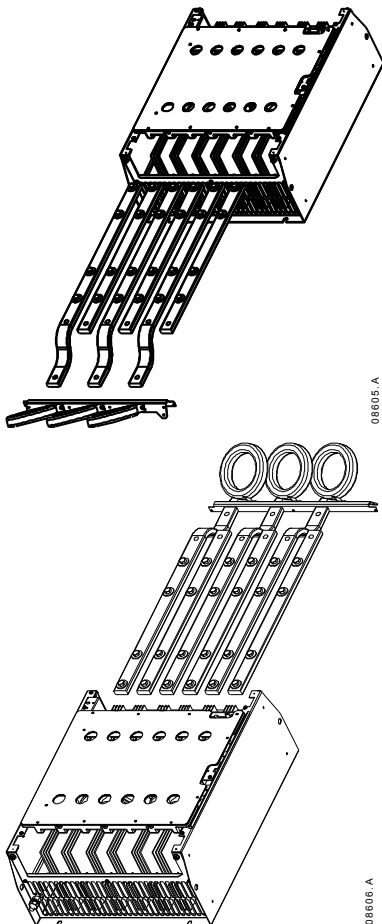

10. Unscrew and remove the magnetic bypass plates (models ASAB-0620C to ASAB-1600C only).
11. Remove the current transformer assembly (three screws).
12. Identify which busbars are to be moved. Remove the bolts holding these busbars in place then slide the busbars out through the bottom of the starter (four bolts per busbar).

13. Slide the busbars in through the top of the starter. For input busbars, the short curved end should be outside the starter. For output busbars, the unthreaded hole should be outside the starter.
14. Replace the dome washers with the flat face towards the busbar, then tighten the bolts holding the busbars in place to 20 Nm.
15. Place the current transformer assembly over the input busbars and screw the assembly to the body of the starter (see note).
16. Run all wiring to the side of the starter and secure with cable ties.



NOTE

If moving the input busbars, the current transformers (CTs) must also be reconfigured.

1. Label the CTs L1, L2 and L3 (L1 is leftmost when looking from the front of the starter). Remove the cable ties and unscrew the CTs from the bracket.
2. Move the CT bracket to the top of the starter. Position the CTs for the correct phases, then screw the CTs to the bracket. For models ASAB-0380C ~ ASAB-0930C, the CTs must be placed on an angle (the left hand legs of each CT will be on the top row of holes and the right hand legs will be on the bottom tabs).

15P0078B1

